

HAPG mosaic crystal Von Hamos spectrometer for high precision exotic atoms spectroscopy

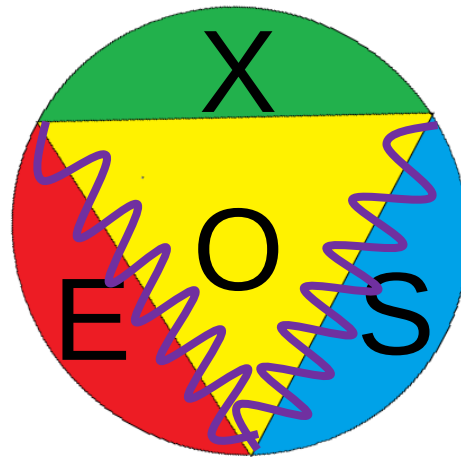

Alessandro Scordo

Laboratori Nazionali di Frascati, INFN



Kaonic atoms

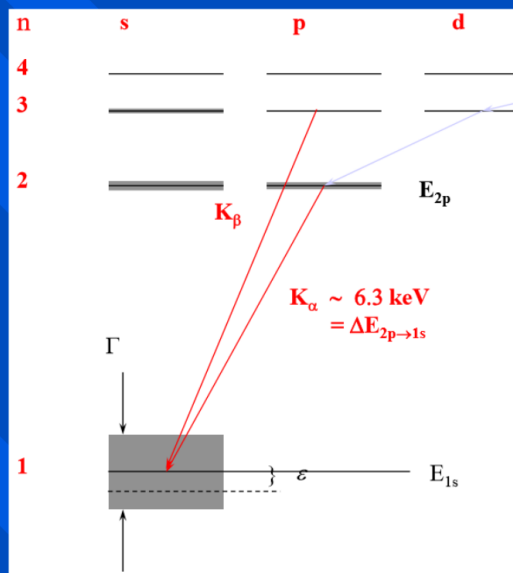
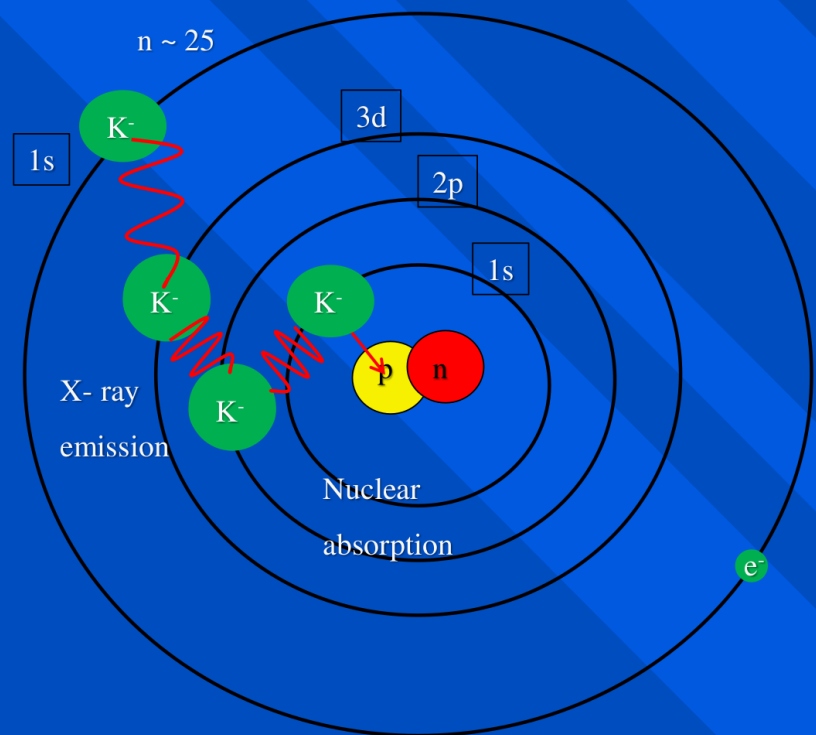

From shift and widths low energy QCD parameters like Isospin-dependent scattering length may be extracted

Different theoretical approaches to KN interaction lead to different predictions

Depending on the atom and on the energy level, predicted values of shifts and widths can range from 0.1 eV up to almost 1 MeV

$$n \simeq \sqrt{\frac{m_{red}}{m_e}} n_e$$

$$E_{1s} \simeq m_{red} c^2 \frac{\alpha^2 Z^2}{2}$$

Strong interaction causes a shifting of the energy of the lowest atomic level from its purely electromagnetic value

Absorption reduces the lifetime of the state, so Xray transitions to this final atomic level are broadened.

High energy values can be measured with high accuracy, using standard solid state X-ray detectors

Transitions with shifts and widths of few eV (or below) need, instead, a technological boost to be measured with the necessary precision



$$\epsilon_{1s} = -283 \pm 36(\text{stat}) \pm 6(\text{syst}) \text{ eV}$$

$$\Gamma_{1s} = 541 \pm 89(\text{stat}) \pm 22(\text{syst}) \text{ eV}$$

Kaonic hydrogen

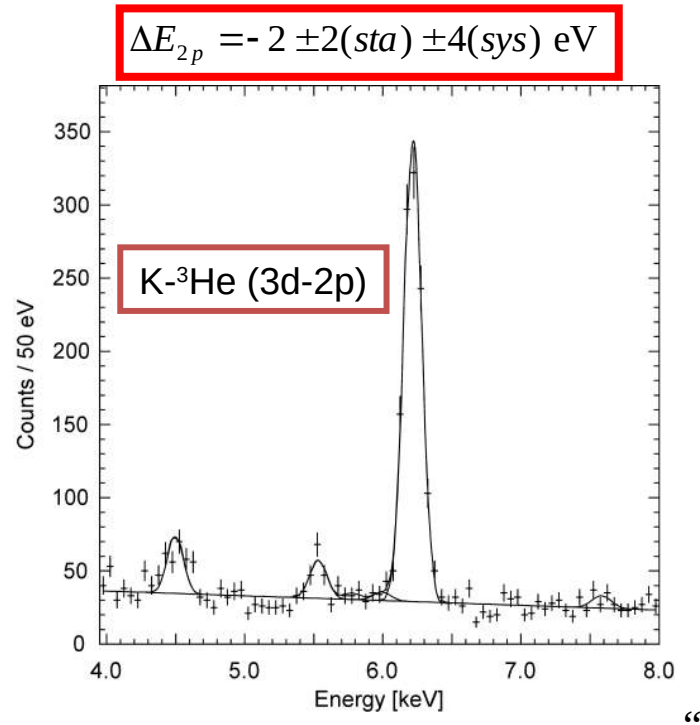
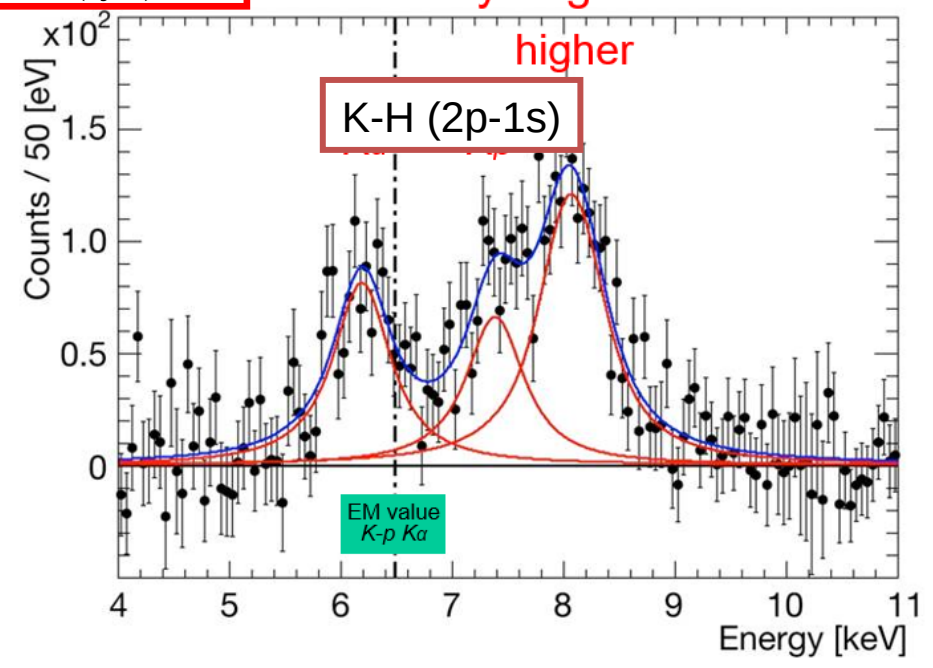
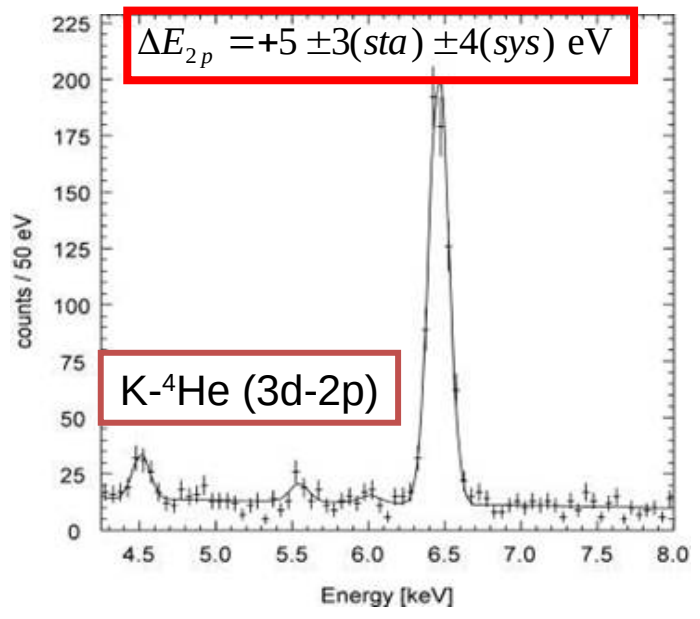

Achievable
precisions:
 $\Delta\epsilon(1s) = 30 \text{ eV}$
 $\Delta\Gamma(1s) = 70 \text{ eV}$

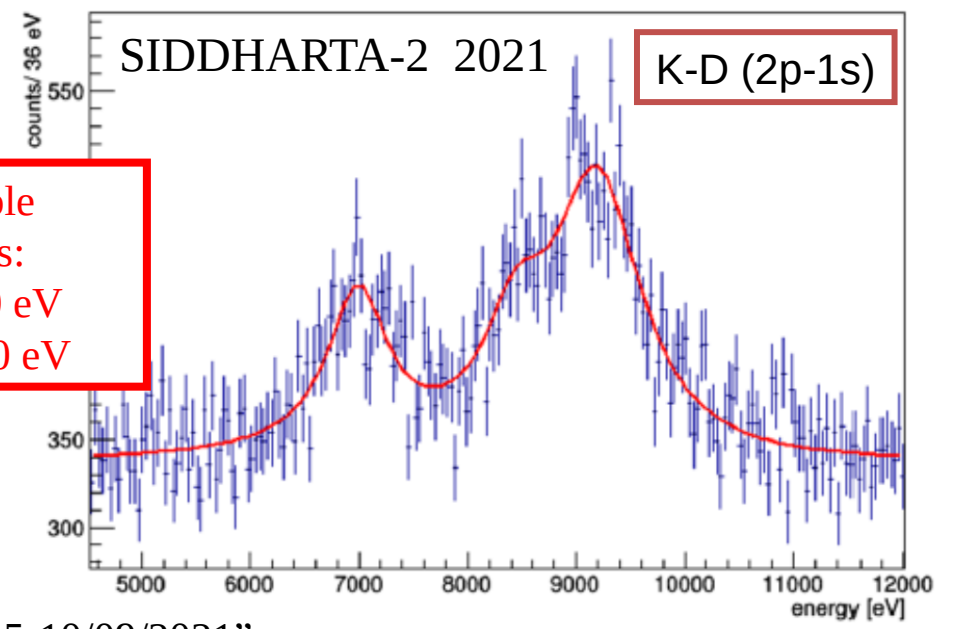

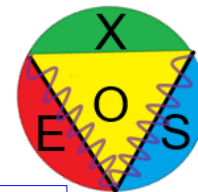

FWHM obtained in these measurements are already at the Fano limit for solid state detectors

Precisions of 1 ~ 50 eV, depending on the statistics, can be reached with this FWHM

These values of FWHM and σE are not enough for many other measurements:

Example: KHe widths measured by SIDDHARTA

$$\Gamma_{2p}({}^3\text{He}) = 6 \pm 6 \text{ (stat.)} \pm 7 \text{ (syst.) eV}$$

$$\Gamma_{2p}({}^4\text{He}) = 14 \pm 8 \text{ (stat.)} \pm 5 \text{ (syst.) eV}$$

Example: Upper level measurements with very small Γ

An advantage of "upper levels"*

SŁAWOMIR WYCECH

In analogy to antiprotons the scenario under the $\bar{K}N$ threshold is determined by a resonant state $\Lambda(1405)$ with a pole close to E_{cm} 1410 MeV that is in the ${}^3\text{He}$ region. On the other side one has $\Sigma(1385)$ state which exerts maximum repulsive effect in the ${}^4\text{He}$ region. Apparently these two main agents yield attractive shift in ${}^3\text{He}$ and repulsive in ${}^4\text{He}$. Now, in order to go above the errors one has to magnify the shifts and enhance the atomic-nuclear overlaps. The proper targets would be ${}^8\text{Be}$ and ${}^6,7\text{Li}$. These offer similar values of E_{cm} as ${}^4\text{He}$ and ${}^3\text{He}$. A simple re-scaling of overlaps generates the level shifts of about 100 eV. One should perhaps consider also studies of $3D$ levels in these atoms. One interesting outcome might be the estimate where the isospin 0 $\text{Re } T(\bar{K}N \rightarrow \bar{K}N)$ amplitude crosses zero. That will help to settle the controversy as to where is the $\Lambda(1405)$ pole in the complex plane located.

Example: Kaon mass measurement

Charged Kaon Mass

Claude Amsler¹ and Simon Eidelman^{2,3,4}

¹Stefan Meyer Institute, Vienna, Austria

²Budker Institute of Nuclear Physics, Novosibirsk, Russia

³Novosibirsk State University, Novosibirsk, Russia

⁴Lebedev Physical Institute, Moscow, Russia

January 10, 2021

2003 [6]) was the first enigmatic state whose properties cannot be fully understood in the framework of the quark model. Despite very extensive efforts (the discovery paper with 1880 citations is one of the most cited experimental publications), there is no consensus today about its internal structure. The most popular explanation is that it is a mixture of a regular $q\bar{q}$ state and a $D^0\bar{D}^{*0}$ molecule. To test the validity of the molecular hypothesis it is of vital importance to know precisely how far the $\chi_{c1}(3872)$ state lies from the D^0D^{*0} threshold. Recently LHCb performed a study of $\chi_{c1}(3872)$ produced in decays of B^\pm mesons and other b hadrons [7, 8]. Using the world-largest sample of almost 20k $\chi_{c1}(3872) \rightarrow J/\psi\pi^+\pi^-$ decays, LHCb performed the most precise measurement of the $\chi_{c1}(3872)$ mass and of the energy difference $\delta E = m(D^0) + m(D^{*0}) - m(\chi_{c1}(3872)) = 0.07 \pm 0.12$ MeV. Again, the precision is limited by that of the charged kaon mass.

The precision on the D^0 mass also affects the mixing parameters in the $D^0-\bar{D}^0$ system [4], and in the long run, a more accurate kaon mass may become interesting for first-principle calculations on the lattice [9].

Example: Fine splitting of kaonic atoms levels for cascade processes

Bragg spectroscopy

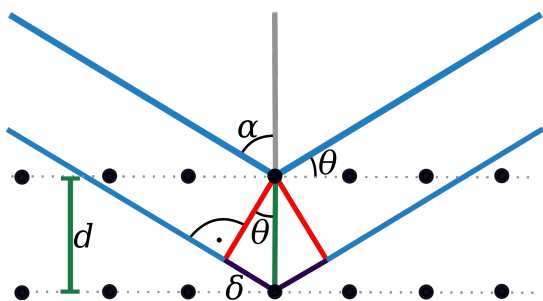

$$n\lambda = 2d\sin\theta_B$$

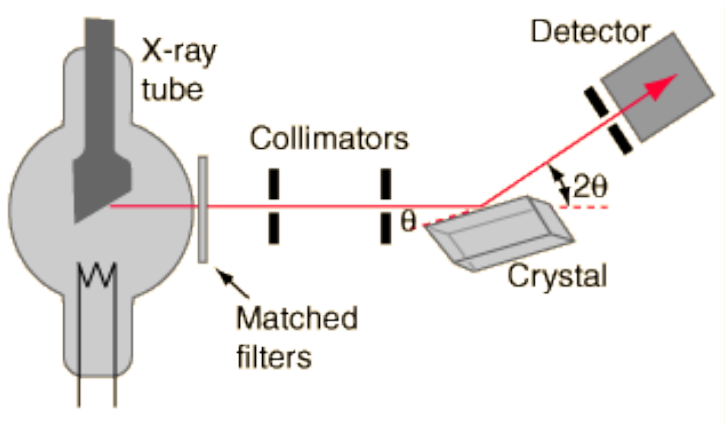

FWHM \sim 1-10 eV can be achieved depending on the quality of the crystal and the dimensions of the detectors

Natural background reduction from geometry

But....

- Small solid angles can be covered
- Typical efficiencies : $10^{-5} - 10^{-8}$
- Typical d (Si) \approx 5.5 Å (good for $E < 6$ keV)
- Typical source size 10-100 μ m

The x-ray source, which was used for the measurements, is a low power microfocus x-ray tube (IfG) with a source diameter of about 50 μ m. Measurements were performed with the Cu K_{α} emission of a Cu anode at 8 keV. The spec-

III. SPECTROMETER SETUP

The spectrometer consists of three principal components: the X-ray source, the HAPG optic, and the position sensitive detector. As source a watercooled 100 W micro focus X-ray tube with a tungsten anode and a focus size of 50 μ m is used. The emitted radiation is focused onto the sample by a polycapillary full lense with a spot size of 35 μ m. The HAPG

Laser-produced plasmas were created using the “Phoenix” Nd glass laser (the Lebedev Physical Institute) operated at a wavelength of 0.53 μ m with pulse energy up to 10 J and 2 ns pulse duration. The laser beam was focused onto massive Mg, Al, Ti, or Fe targets (see Fig. 2). The focal spot diameter was about ~15 μ m.



Mosaic crystal consist in a large number of nearly perfect small crystallites.

Mosaicity makes it possible that even for a fixed incidence angle on the crystal surface, an energetic distribution of photons can be reflected

Increase of efficiency
(focusing) ~ 50

Loss in resolution

Pyrolytic Graphite mosaic crystals ($d = 3.354 \text{ \AA}$):

- Bending does not influence resolution and intensity
- Mosaic spread down to 0.05 degree
- Integral reflectivity $\sim 10^2$ higher than for other crystals
- Variable thickness (efficiency)
- Excellent thermal and radiation stability

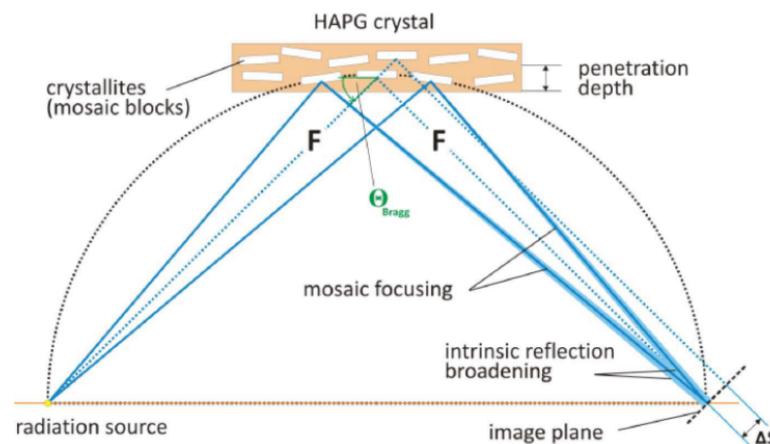

Integral reflectivity

- Measured integral reflectivities (synchrotron measurements)

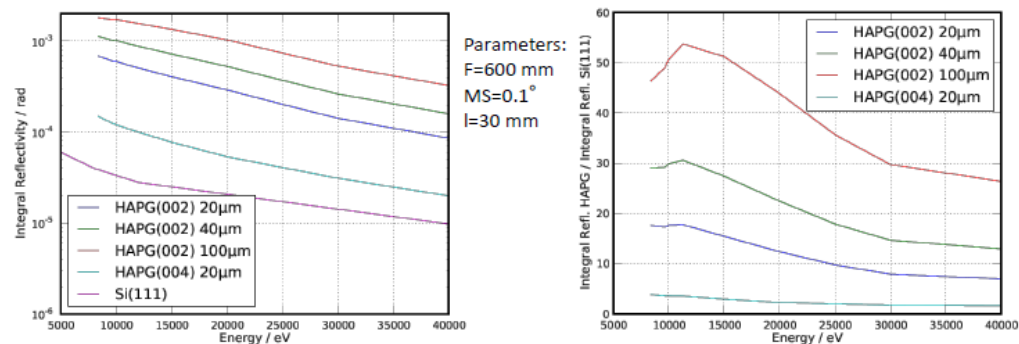

- The integral reflectivity can be more than 50 times higher compared to Si(111) reflection.
- The use of the von Hamos geometry can increase the overall efficiency even more.

Characterization of HAPG mosaic crystals using synchrotron radiation

Martin Gerlach,^a Lars Anklamm,^b Alexander Antonov,^c Inna Grigorieva,^c Ina Hofelder,^a Birgit Kanngießer,^b Herbert Legall,^c Wolfgang Malzer,^b Christopher Schlesiger^b and Burkhard Beckhoff^{a*}

J. Appl. Cryst. (2015). 48

Von Hamos configuration: improving solid angle

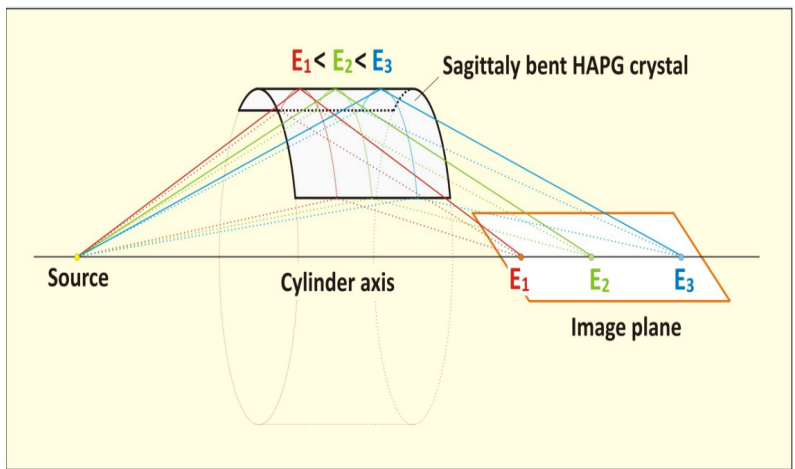
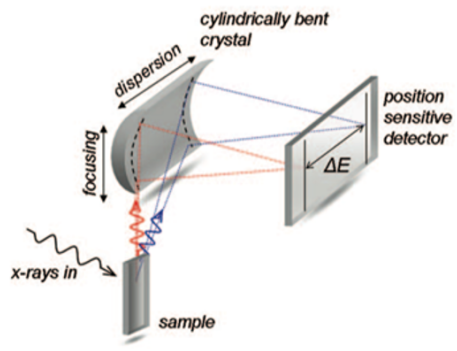

VH configuration can further improve the signal collection efficiency.

In this configuration, also the vertical dimension of the X-ray source can be exploited

distance: $F = 400$ mm in (004)-reflexion @ 8 keV (Cu K_{α})

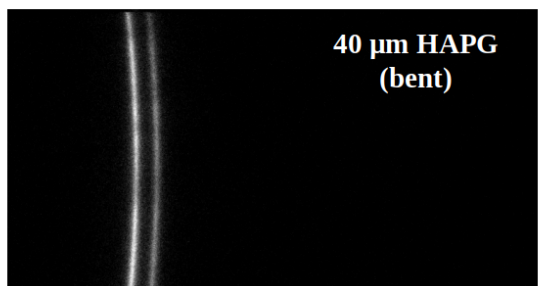
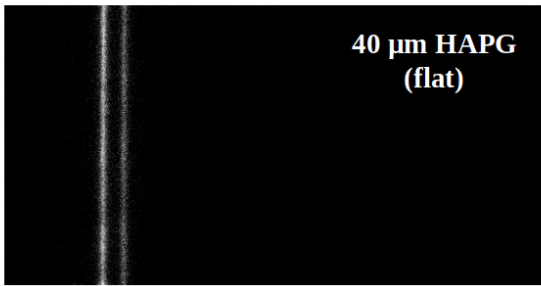

Spectral resolution of bent HAPG/HOPG crystal is comparable to the flat one !

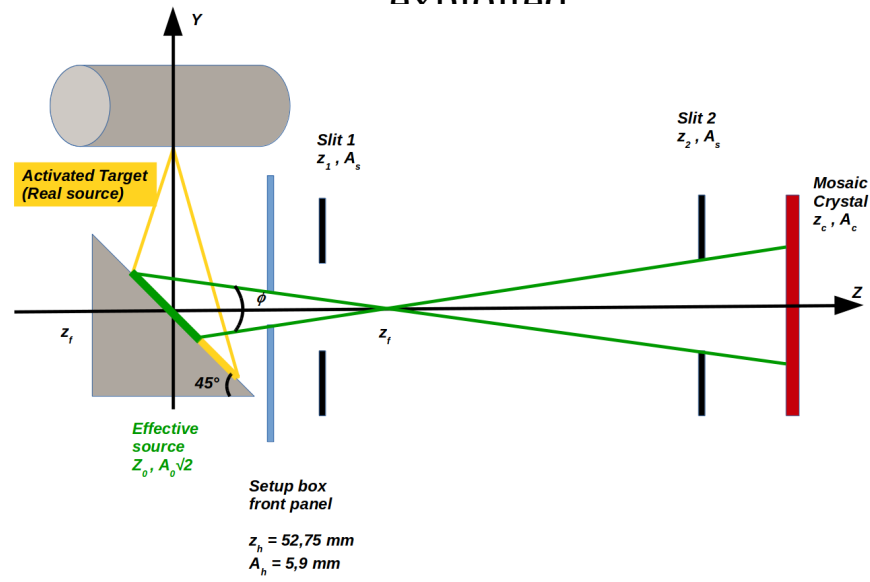

H. Legall, H. Stiel, I. Grigorieva, A. Antonov et al., FEL Proc. 2006

VOXES: enlarging the source size

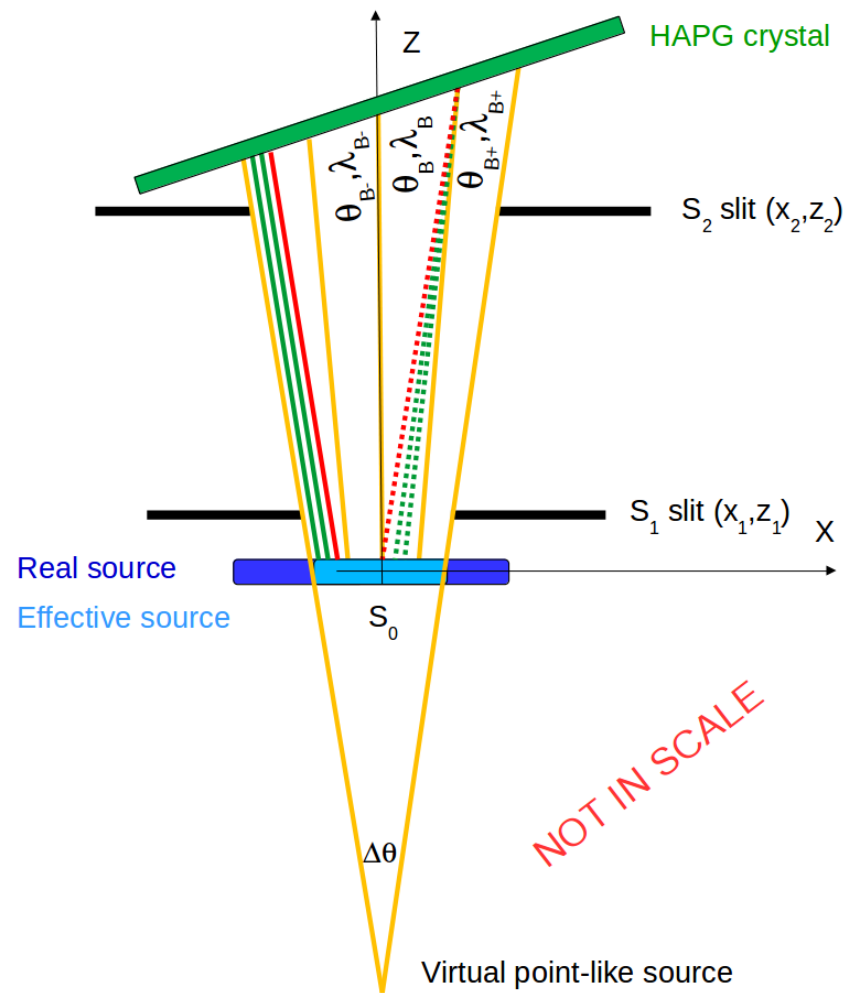
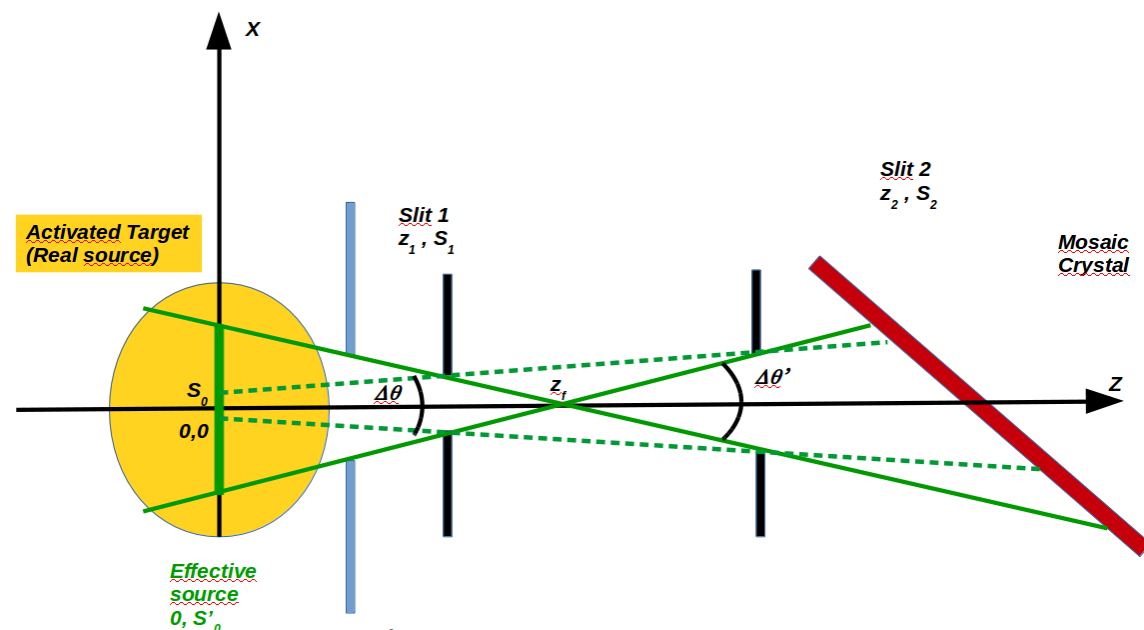
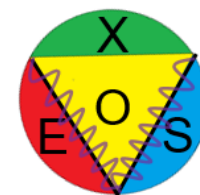

The shape of the “signal” beam can be optimized to increase the effective source size

On the other hand, this may lead to a worsening of the resolution

How big can a source be keeping FWHM < 10 eV?

VOXES: setup

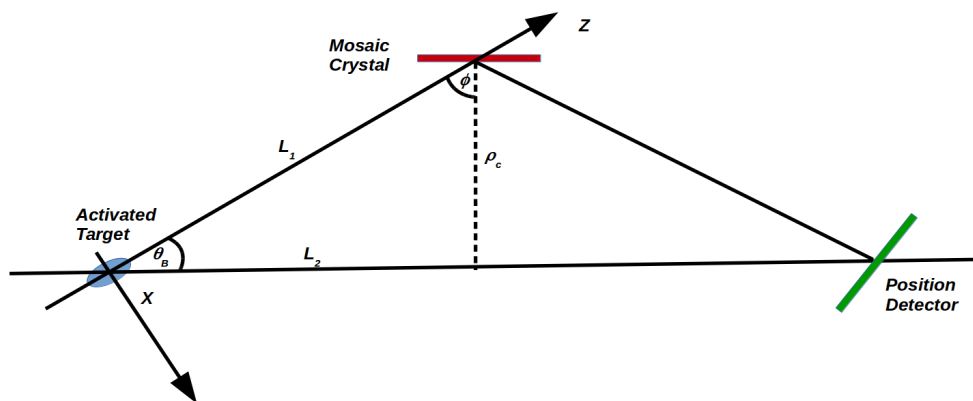

Table 1 List of the X-ray lines measured in this work and the corresponding Bragg angles θ_B

Line	E (eV)	θ_B (°)
Fe($K_{\alpha 1}$)	6403,84	16,77
Fe($K_{\alpha 2}$)	6390,84	16,81
Cu($K_{\alpha 1}$)	8047,78	13,28
Cu($K_{\alpha 2}$)	8027,83	13,31
Ni(K_{β})	8264,66	12,92
Zn($K_{\alpha 1}$)	8638,86	12,35
Zn($K_{\alpha 2}$)	8615,78	12,39
Mo($K_{\alpha 1}$)	17479,34	6,07
Mo($K_{\alpha 2}$)	17374,30	6,11
Nb(K_{β})	18622,50	5,70

For a given X-ray energy the Bragg angle (θ_B) and the curvature radius of the crystal (ρ_c) completely determine the position of the source, the crystal and the position detector

$$L_1 = \frac{\rho_c}{\sin\theta_B}$$

$$L_2 = L_1 \sin\phi$$

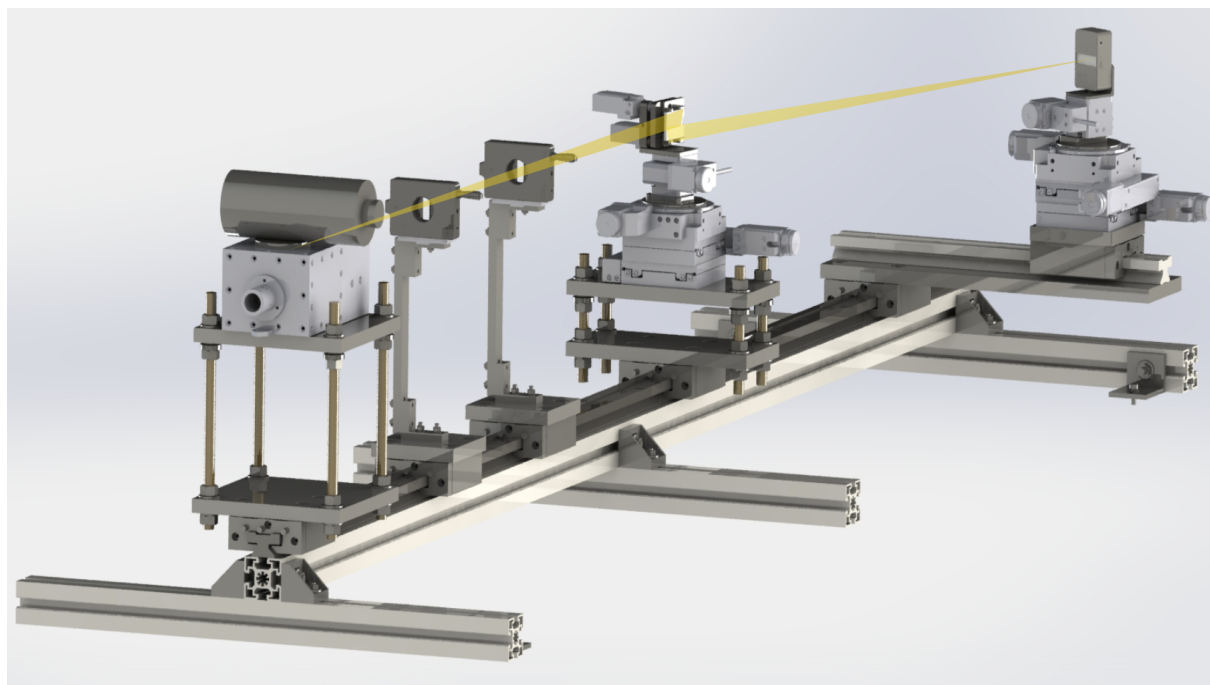

VOXES: results

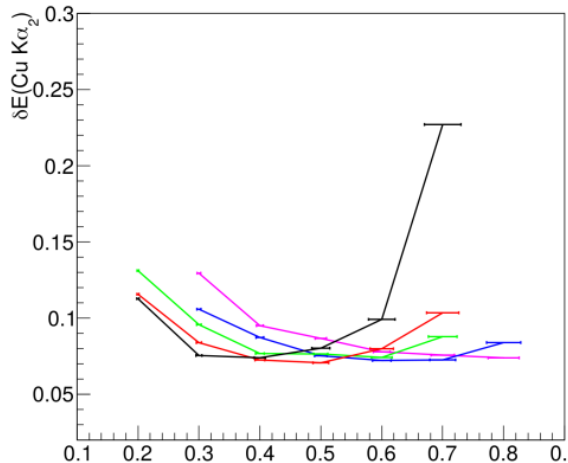
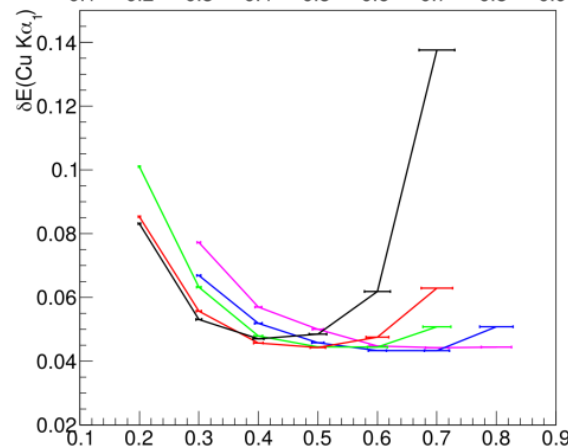
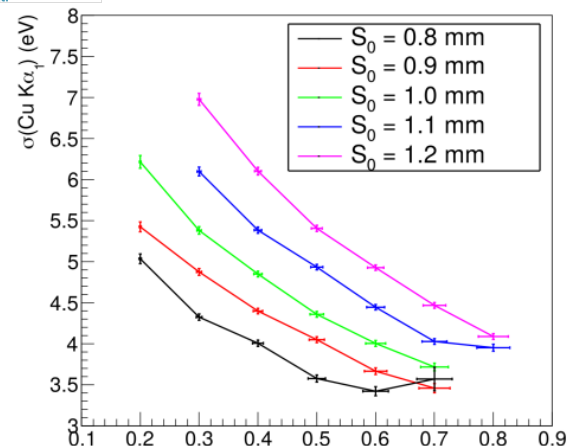
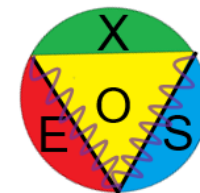

In the limit of a background free pure gaussian peak, the precision is related to the resolution via:

$$\delta E = \frac{\sigma E}{\sqrt{N}}$$

$$\frac{3,6}{\sqrt{4323}} = 0,0547 \text{ eV}$$

Given the energy and ρ_c it is always possible to find the optimal configuration to obtain the best peak position precision

Valid for all energies (tested for 6-20 keV)

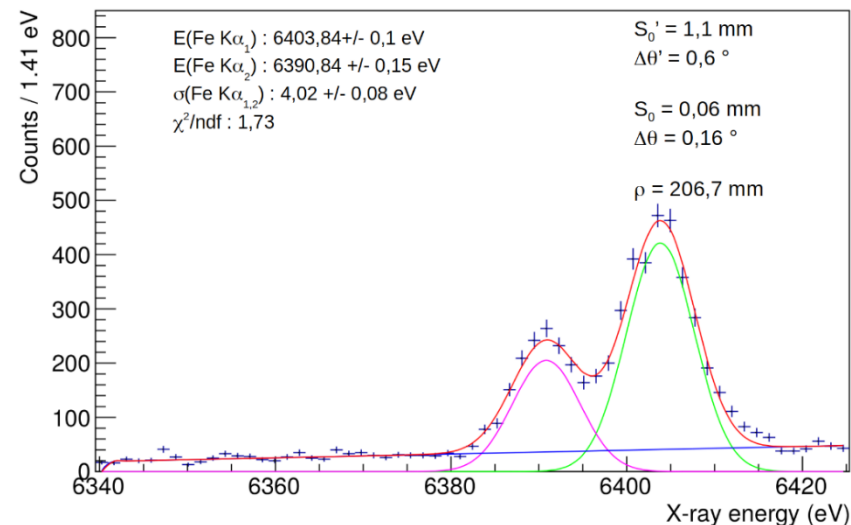
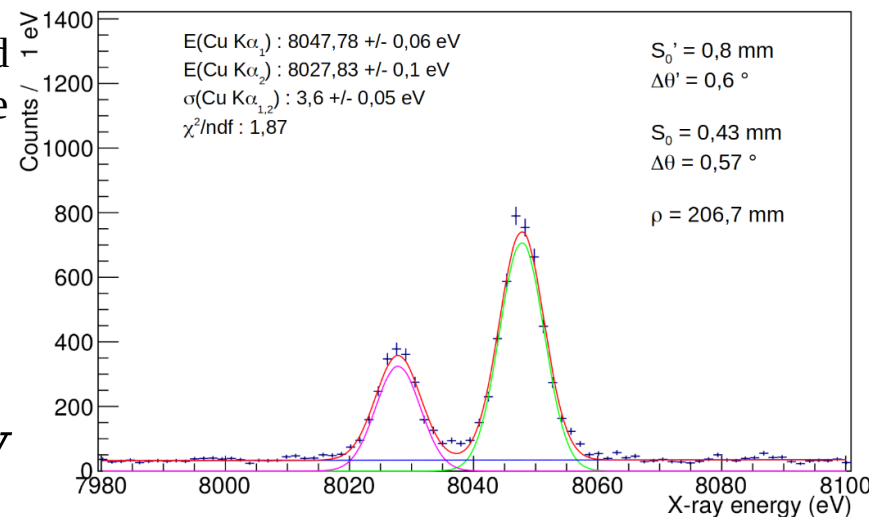

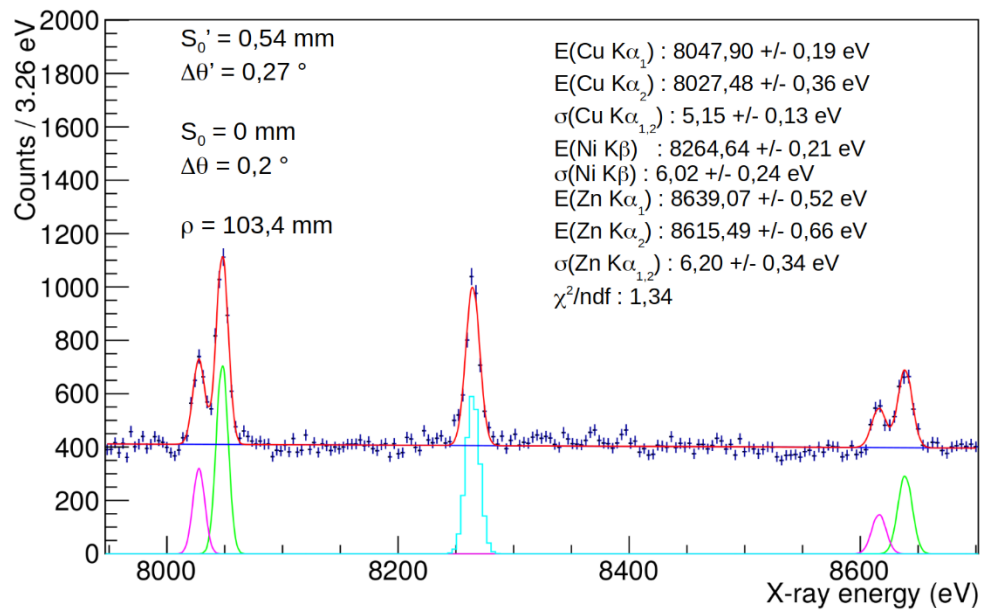

700 eV dynamic range (one shot)

Resolution still at 6 eV level (σ)

>1 keV dynamic range

Resolution still at 1,2 ‰

Almost 2 mm source size

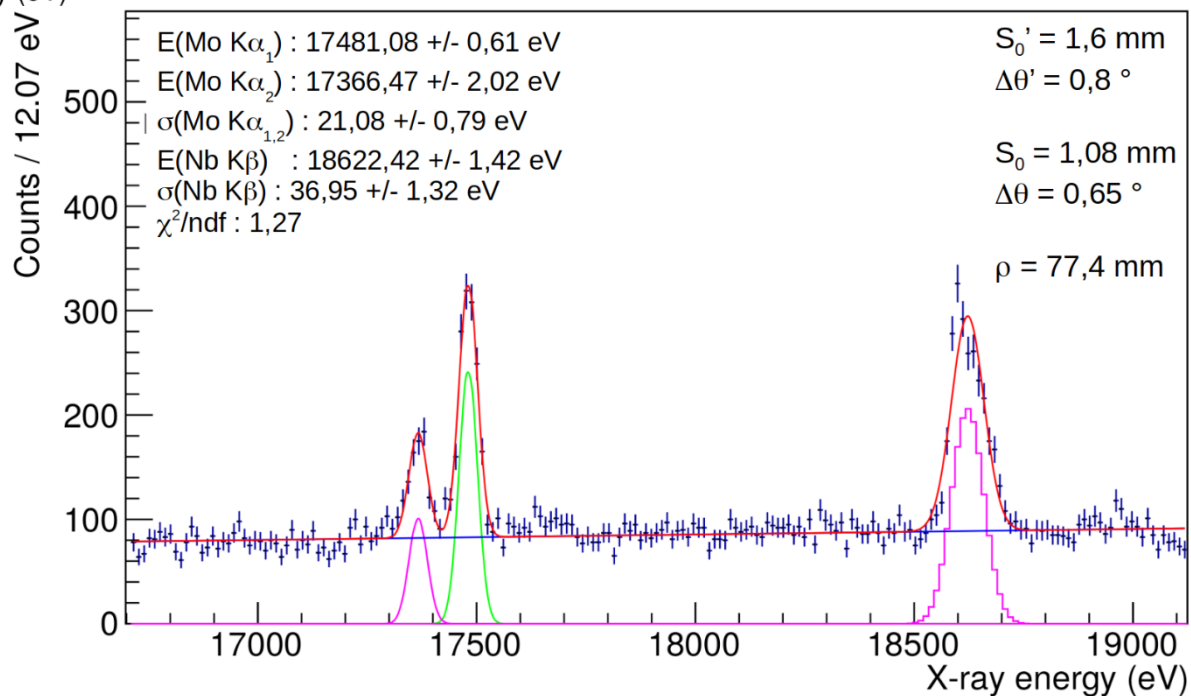

VOXES: ray tracing simulations

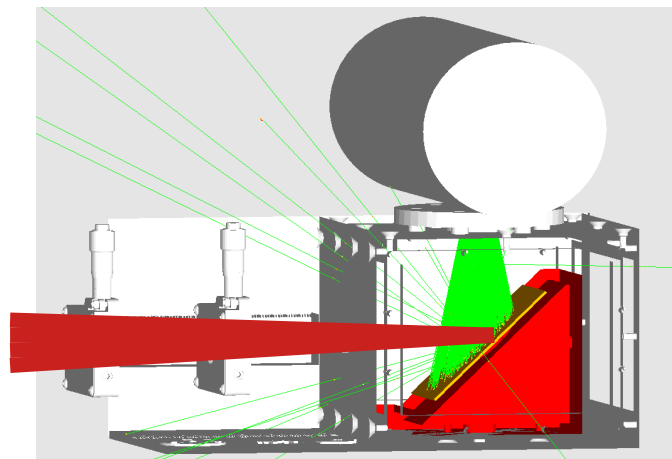
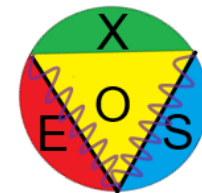

Software:
XOP → HAPG and ray tracing
SHADOW → Visualization

Integrated in OASYS tool

22 G. Hölzer *et al.*, *Phys. Rev. A*, 1997, **56**, 4554–4568.

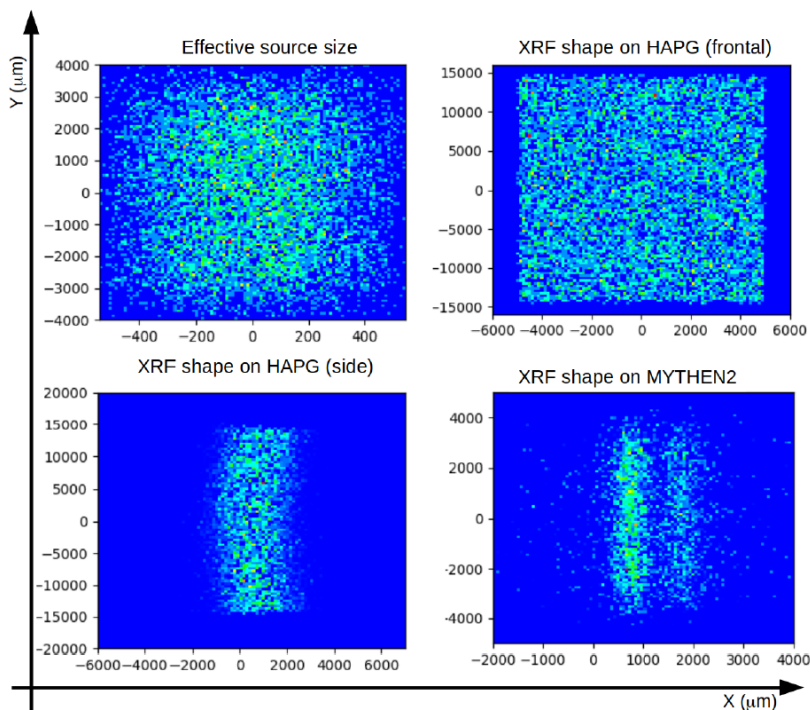
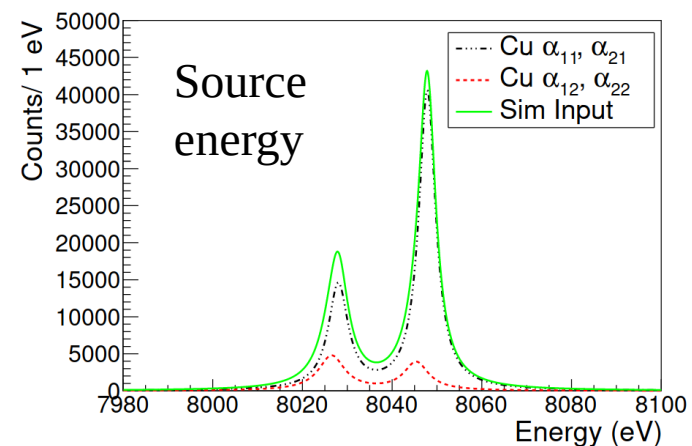

The physical source size is large (2,5x 2,5 cm)

We want to check the effective source size dimensions as coming from ray tracing simulations

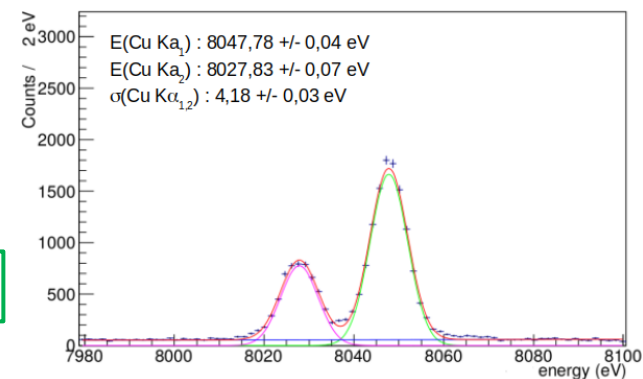
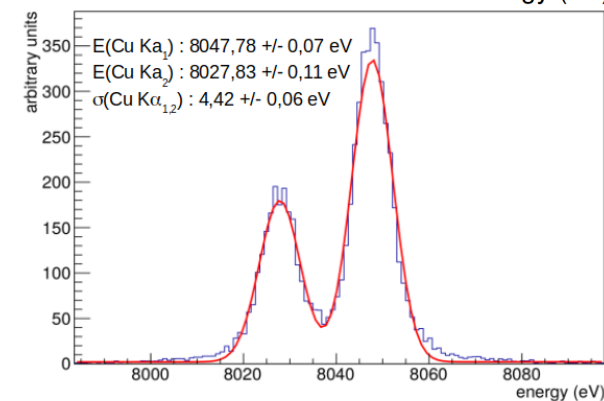

Peak position and σ well reproduced

VOXES: ray tracing simulations

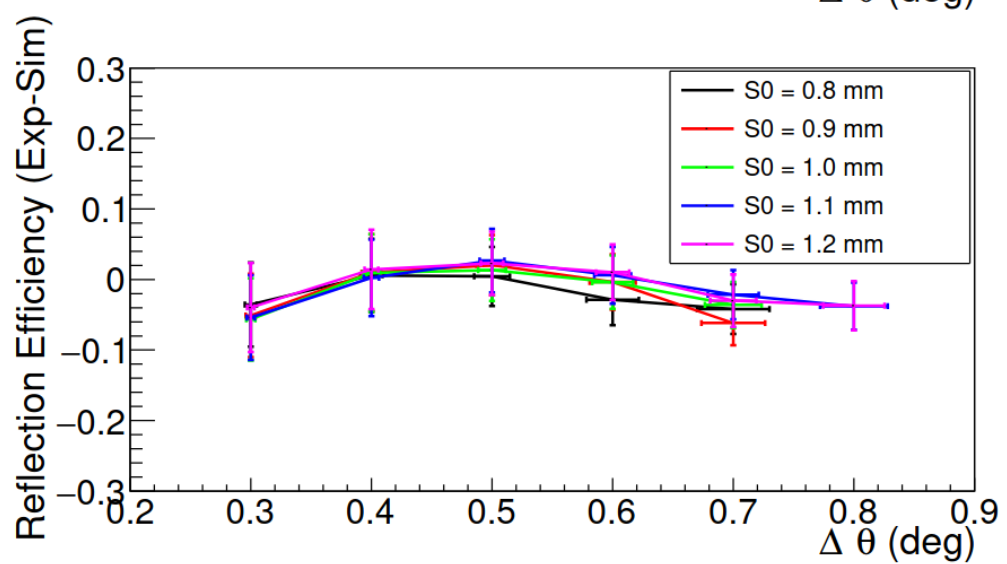
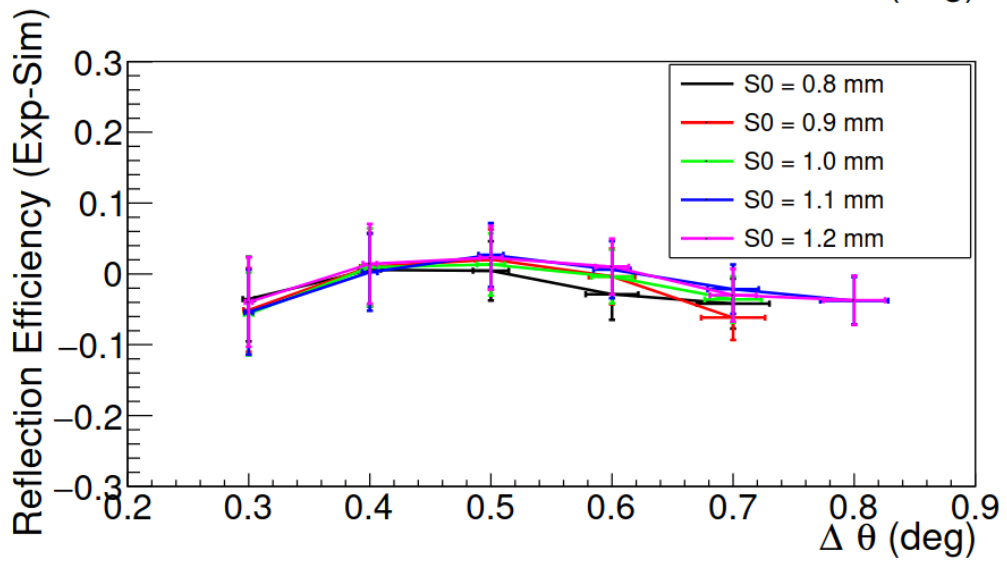
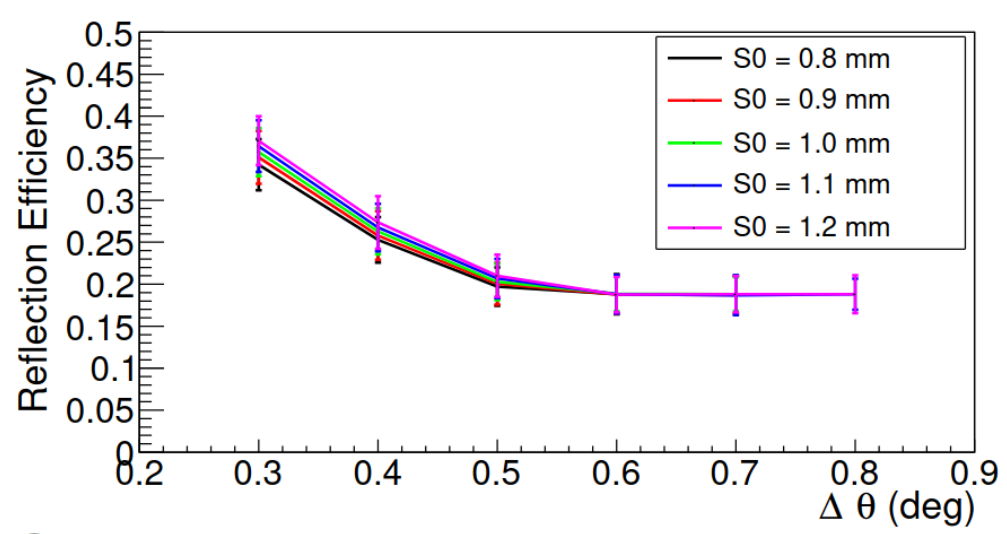
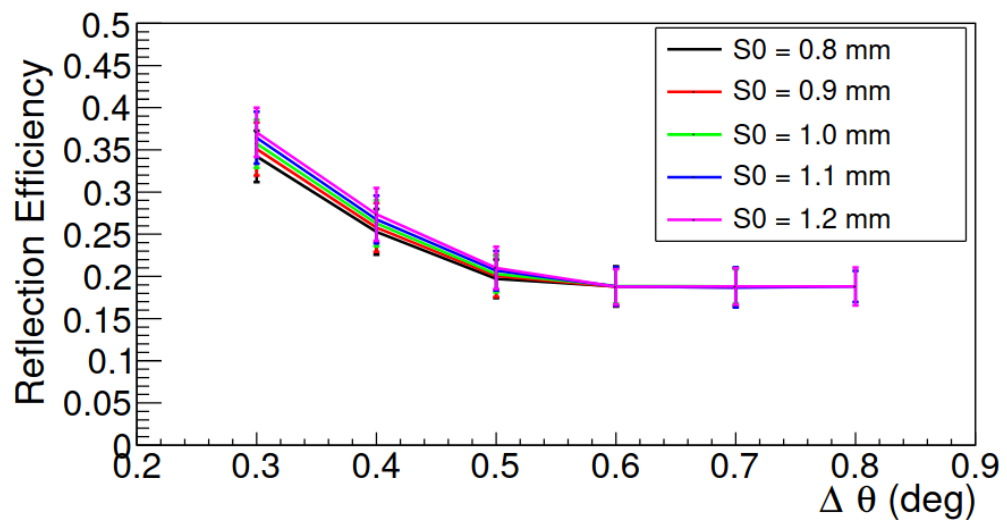

Reflection efficiencies are also well reproduced and under control

Possible kaonic transitions to be measured with HAPG crystal spectrometer:

$K^3\text{He}(3 \rightarrow 2) : 6.2 \text{ keV}$
 $K^3\text{He}(4 \rightarrow 2) : 8.4 \text{ keV}$
 $K^3\text{He}(5 \rightarrow 2) : 9.4 \text{ keV}$
 $K^3\text{He}(6 \rightarrow 2) : 9.9 \text{ keV}$
 $K^3\text{He}(7 \rightarrow 2) : 10.2 \text{ keV}$

$K^4\text{He}(3 \rightarrow 2) : 6.4 \text{ keV}$
 $K^4\text{He}(4 \rightarrow 2) : 8.7 \text{ keV}$
 $K^4\text{He}(5 \rightarrow 2) : 9.7 \text{ keV}$
 $K^4\text{He}(6 \rightarrow 2) : 10.3 \text{ keV}$
 $K^4\text{He}(7 \rightarrow 2) : 10.7 \text{ keV}$

$KN(6 \rightarrow 5) : 7.6 \text{ keV}$
 $KN(7 \rightarrow 5) : 12.1 \text{ keV}$
 $KN(8 \rightarrow 5) : 15.1 \text{ keV}$
 $KN(7 \rightarrow 6) : 4.6 \text{ keV}$
 $KN(8 \rightarrow 6) : 7.5 \text{ keV}$
 $KN(9 \rightarrow 6) : 9.6 \text{ keV}$
 $KN(10 \rightarrow 6) : 11 \text{ keV}$
 $KN(11 \rightarrow 6) : 12.1 \text{ keV}$
 $KN(10 \rightarrow 7) : 6.5 \text{ keV}$
 $KN(11 \rightarrow 7) : 7.5 \text{ keV}$
 $KN(12 \rightarrow 7) : 8.3 \text{ keV}$

Expected Impact:

- - Kaon mass measurements from different lines in parallel
 - Cascade processes
 - Impact on dark matter search driven experiments using exotic atoms in space (accurate cascade models calculations)
 - Upper level measurements with very small Γ
 - Proton radius puzzle (???)

Manifestation of interest from international institution and research centers (PSI, ...)

Detector Key Points:

- Tunable energy range from 2-20 keV
- Extremely high resolutions of few eV
- Very low background after shielding

Feasibility:

- Working principle tested in laboratory
- Dependence from HAPG parameters well investigated and published (thickness, mosaicity, ...)
 - Consistent Ray Tracing simulations available
- Few eV resolutions confirmed for solid sources with millimetric dimensions

VOXES: a possible preliminary run



First run with KC for a feasibility test and background evaluation

Available:

- 1) Multi - Crystal support structure
- 2) Target (Solid or Liquid/Gas)
- 3) Optics
- 4) Aligment support
- 5) Target box
- 6) Detector
- 7) DAQ (integ. KM)

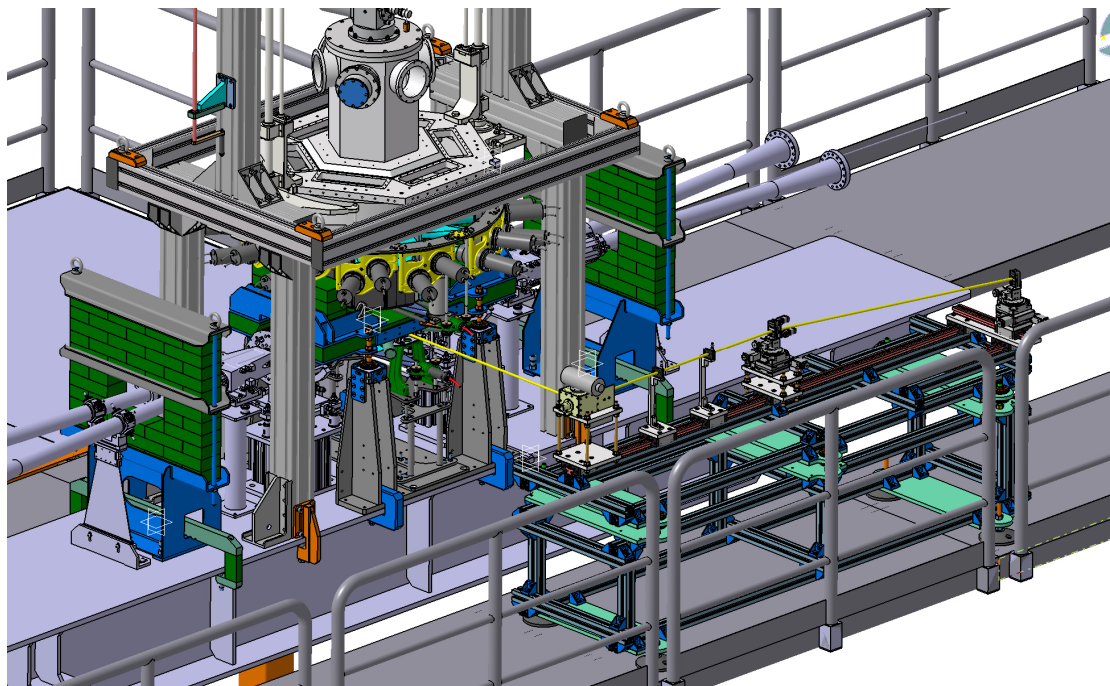

Future implementations:

- Shielding around Detector
- Solid support structure

Possible run in parallel with SIDDHARTA-2 @ LNF
in spring 2022

VOXES: future scenarios on DAΦNE

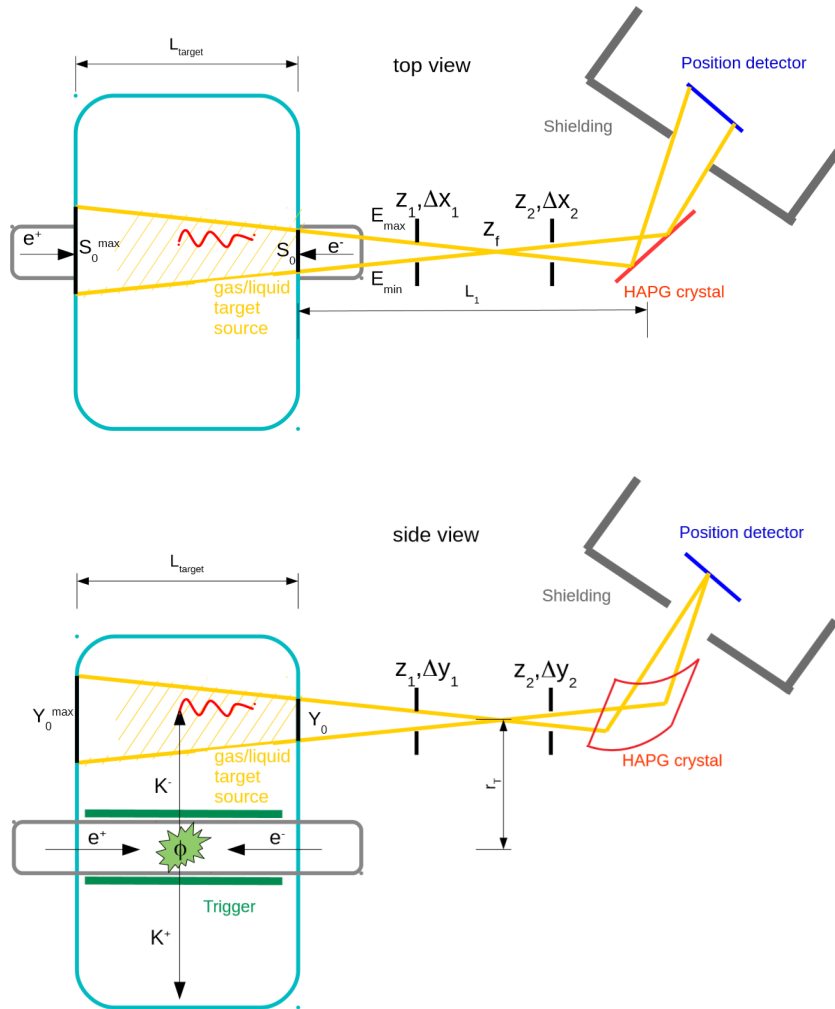

Example:

30 cm cylindrical target around the beampipe with inner trigger (5cm and 40 cm inner and outern radii)

50 cm² HAPG crystals and 10 cm² Position Detectors (total)

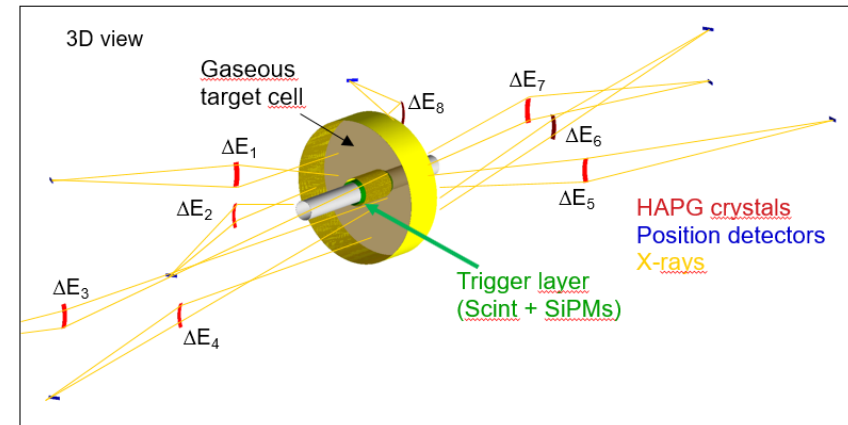

Completely new experiment / setup

Position Detector and HAPG crystals development with R&D opportunities

Real opportunity to apply for external fundings

Possibility to attract new interested institutes

Conclusions



- HAPG based Bragg spectrometers represents a concrete possibility for future sub-eV precision kaonic atoms measurements
- VOXES collaboration developed in Frascati a version of such a spectrometer, to be used also with sources up to mm/cm dimensions
- Detailed investigation and optimization of crystal parameters, calibration procedure and peak shape description has been carried on
- The obtained results are very promising, showing precisions and resolution (well) below 1 eV and 10 eV, respectively
- MC ray tracing simulations have been also performed, which proved to be solid and to perfectly match the data. All these ingredients represent a fundamental starting point for future application
- With a first preliminary test and an expanded ad-hoc setup, VOXES spectrometer has been included in the proposal for future experiments to be carried on at DAΦNE after SIDDHARTA-2:
- “*Fundamental physics at the strangeness frontier at DAΦNE. Outline of a proposal for future measurements*”, arXiv:2104.06076v2 [nucl-ex]

References:

- A. Scordo et al., J. Anal. At. Spectrom., 2020, 35, 155–168.
- A. Scordo et al., Condensed Matter, 2019, 4, 59.
- A. Scordo et al., JINST, 2018, 13, C04002.
- A. Scordo et al., Acta Phys. Polon., 2017, B48, 1715.

Spares



Which is the correct shape to be used for peak fitting?
(Natural linewidths are Lorentzian but....)

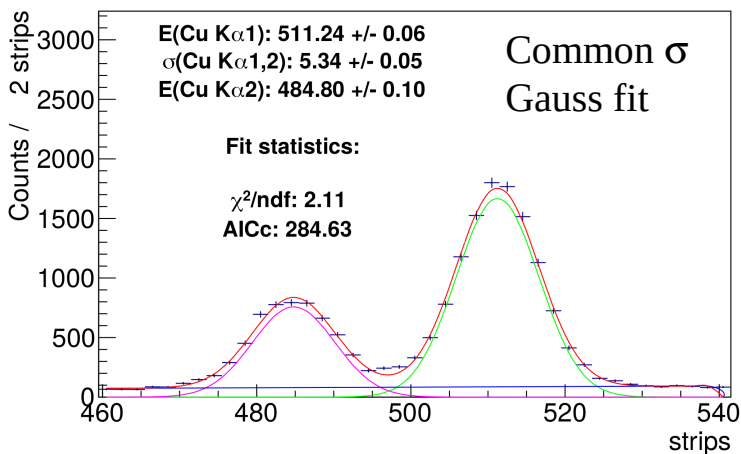
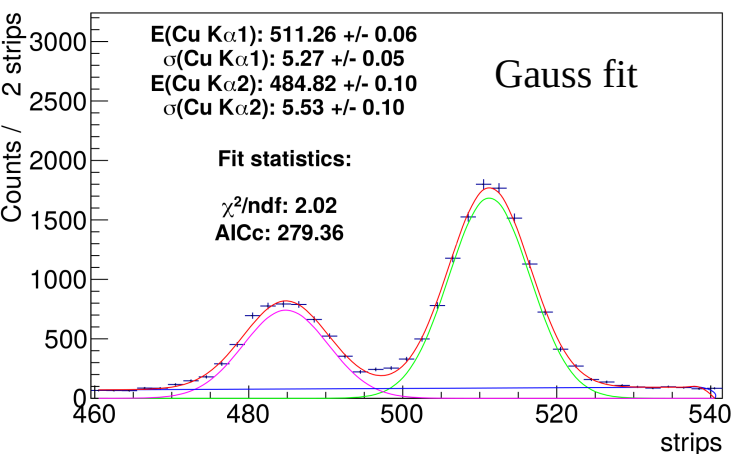
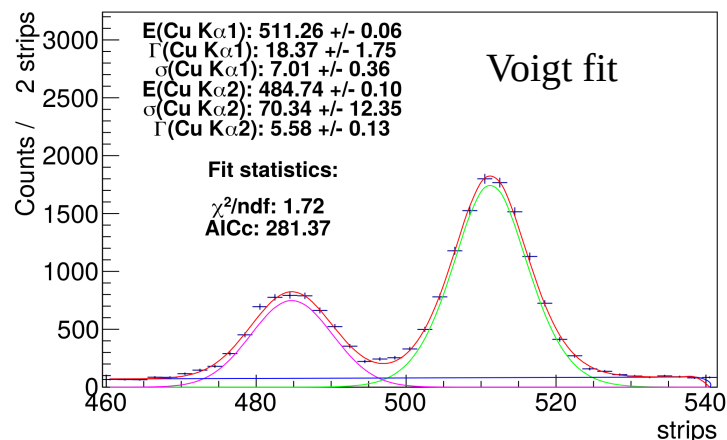
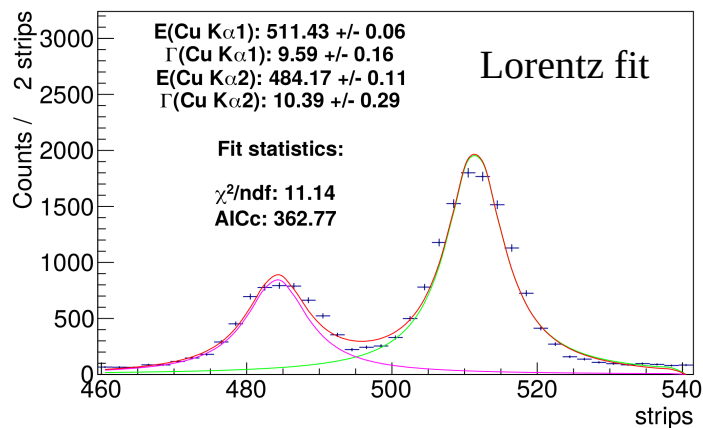

$$V(X) = \frac{A}{2\pi} \frac{\Gamma}{(x-x_0)^2 + \frac{\Gamma^2}{4}} \frac{e^{-\frac{(x-x_0)^2}{2\sigma^2}}}{\sigma\sqrt{2\pi}}$$

Is Voigt really better?

Akaike Information Criteria:

$$AIC = 2p + N \cdot \ln\left(\frac{R}{N}\right)$$

N = num of fitted points

p = num of fit parameters

$$AICc = AIC + \frac{2 \cdot p \cdot (p+1)}{N - p - 1}$$

(for N/p < 40)

Not much information loss using gaussian shape

For each model i the quantity $e^{-0.5(AIC_{\text{cmin}} - AIC_i)}$ is proportional to the probability of the i -th model to minimize the (estimated) information loss as good as the minimum AICc one.

VOXES: energy calibration

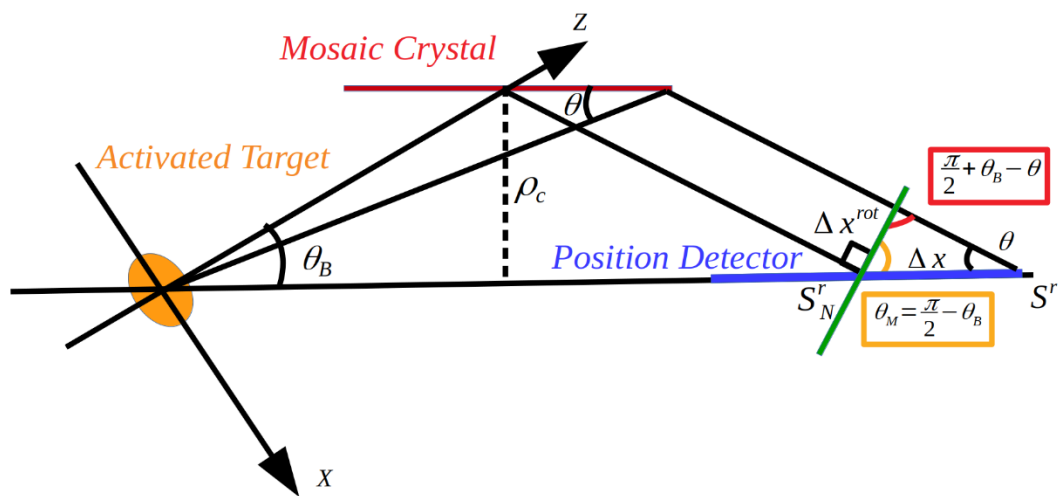

$$S'_0 = 540 \mu\text{m} \text{ and } \Delta\theta' = 0,27^\circ.$$

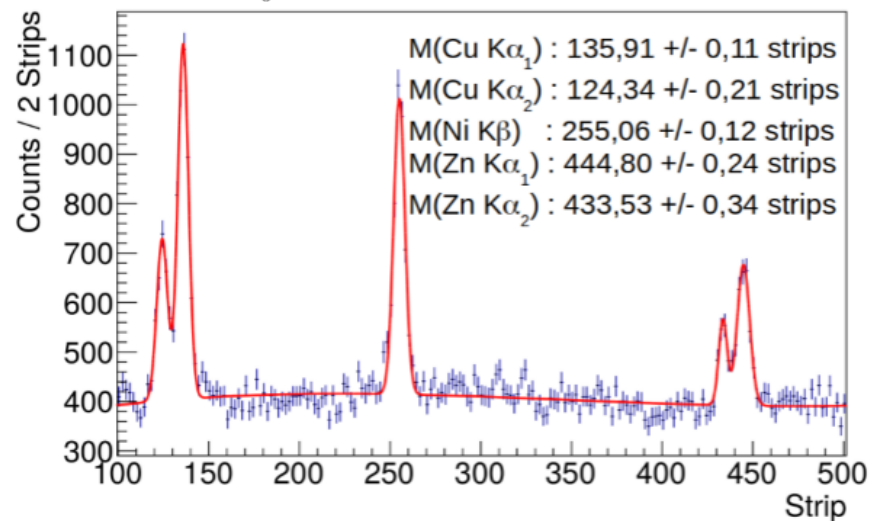

Standard VH calibration: $\Delta x = 2\rho_c \cdot (\cot\theta_B - \cot\theta)$

Semi VH calibration:
$$\Delta x^{rot} = \frac{2\rho_c \cdot (\cot\theta_B - \cot\theta) \cdot \sin\theta}{\sin(\frac{\pi}{2} - \theta_M - \theta)}$$

Parametric form:
$$\Delta x^{rot} = \frac{(A + B \cdot \cot\theta) \cdot \sin\theta}{\sin(\alpha - \theta)}$$

Given the small θ values ($\sin\theta \approx \theta$),
is it also possible to calibrate with a polynomial?

Information loss???

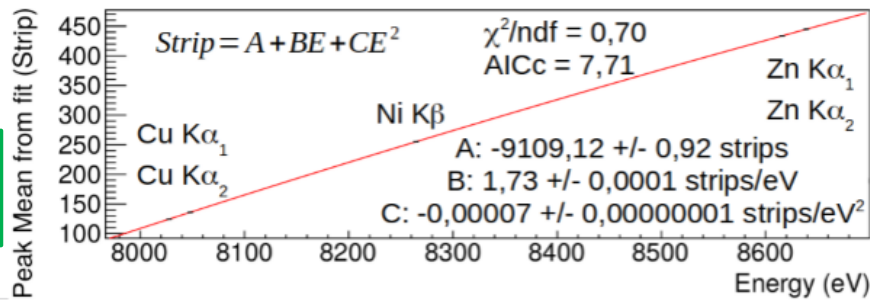
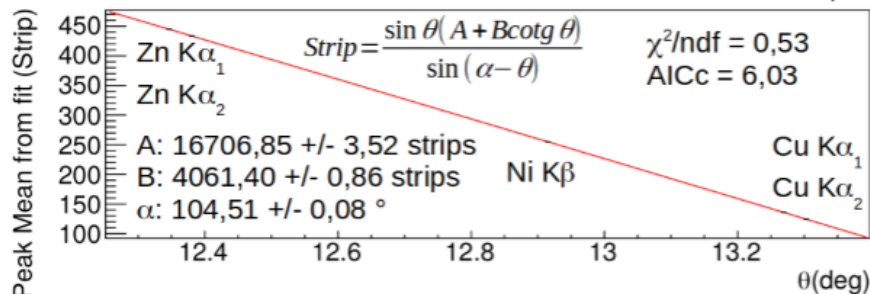

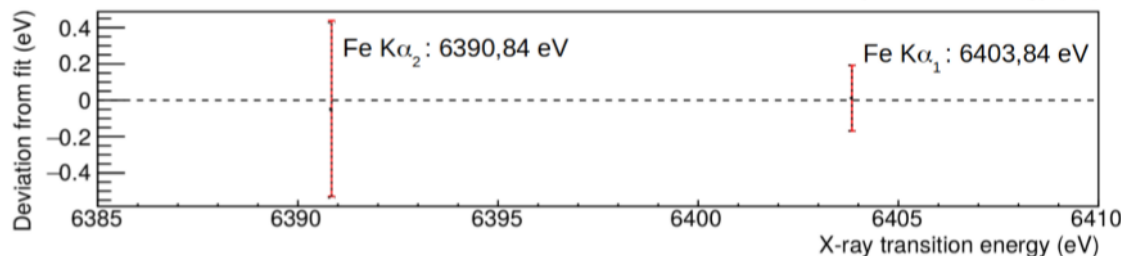
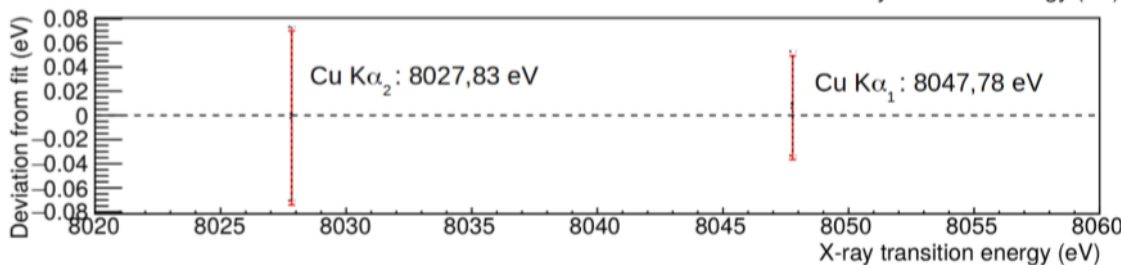
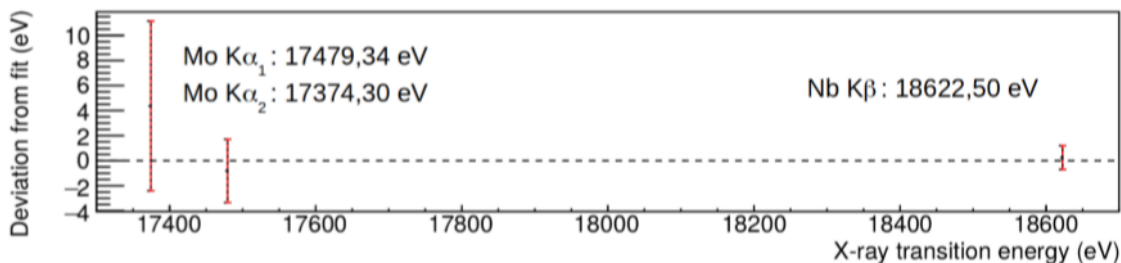
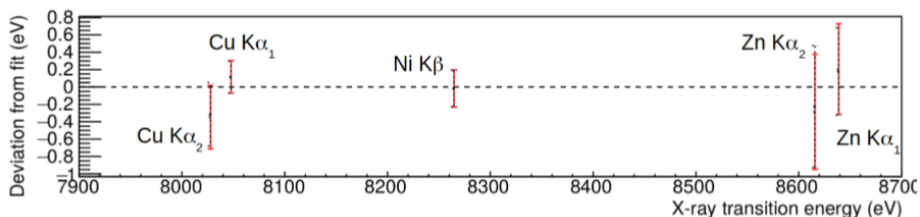
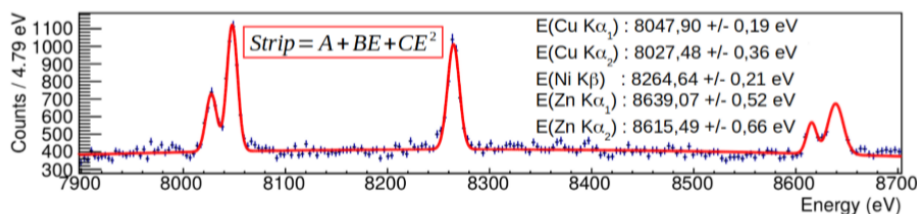
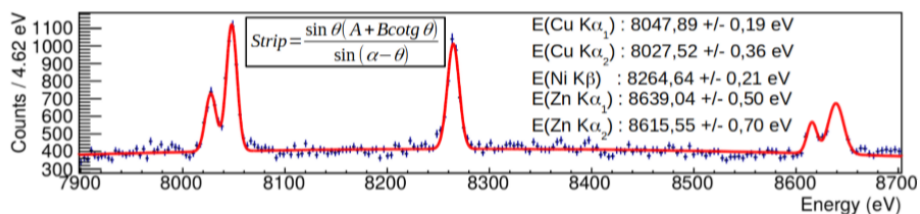

Also valid for higher and wider energy ranges (and higher θ , $\Delta\theta$ values)