



SND@LHC / SHiP

Approved 2021, 1st physics results 2023

Approved 2024

High-Energy Neutrinos & Hidden-Sector Particles

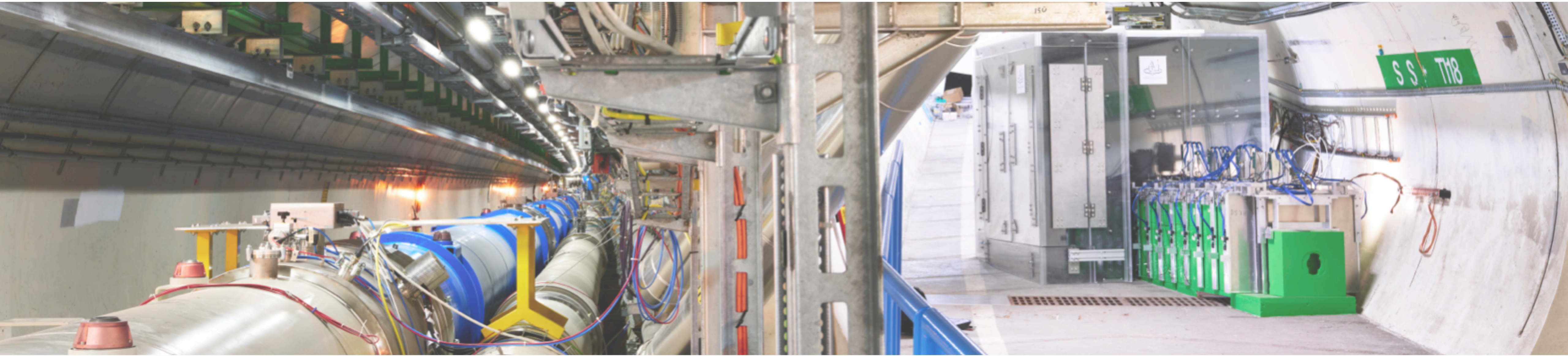
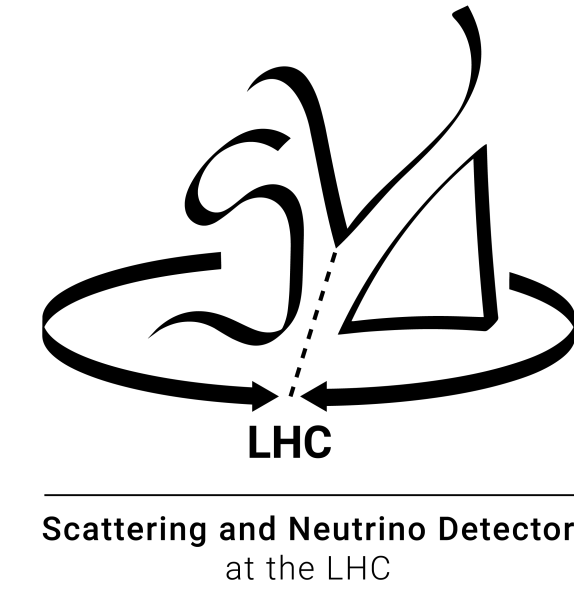

The LIP SND@LHC/SHiP Group

R.Alves, A.Blanco, P.Bordalo, T.Camporesi, P.Fonte, P.Gorbounov,
J.Goulão, N.Leonardo, L.Lopes, S.Ramos, G.Soares, C.Vilela

Interns: R.Castanheira, R.Fernandes, J.Galhardo, A.Santana

Collaborators: R.Biswas (CERN), J.Tesarek (CERN), K.Yi (NNU)



Fundação
para a Ciência
e a Tecnologia

LIP Advisory Committee

Lisbon, April 27rd 2025

(contact: nuno@cern.ch)



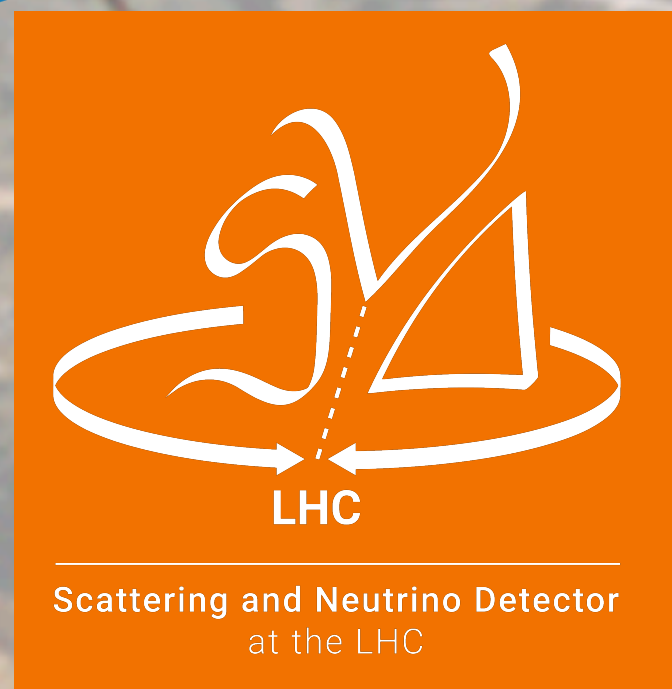
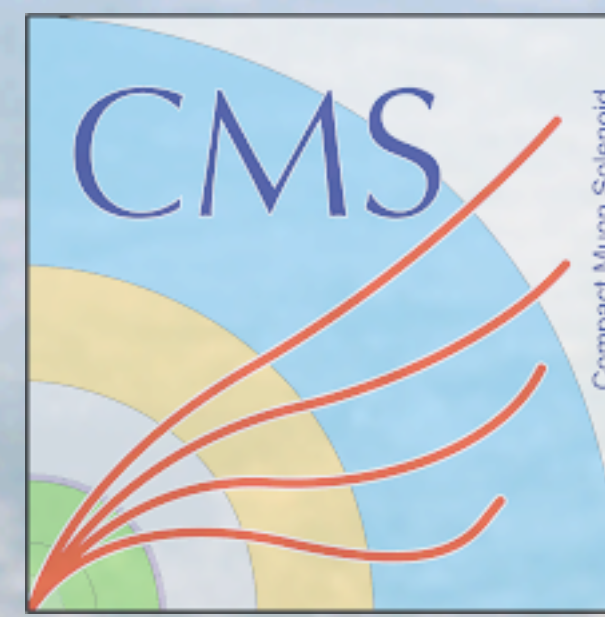

SND@LHC timeline

TECHNICAL PROPOSAL

Scattering and Neutrino Detector at the LHC

CERN approves new LHC experiment

SND@LHC, or Scattering and Neutrino Detector at the LHC, will be the facility's ninth experiment

SND@LHC

January 2021

Letter of Intent

August 2020

March 2021

September 2021



December 2021



Muons from 13.6 TeV pp collision

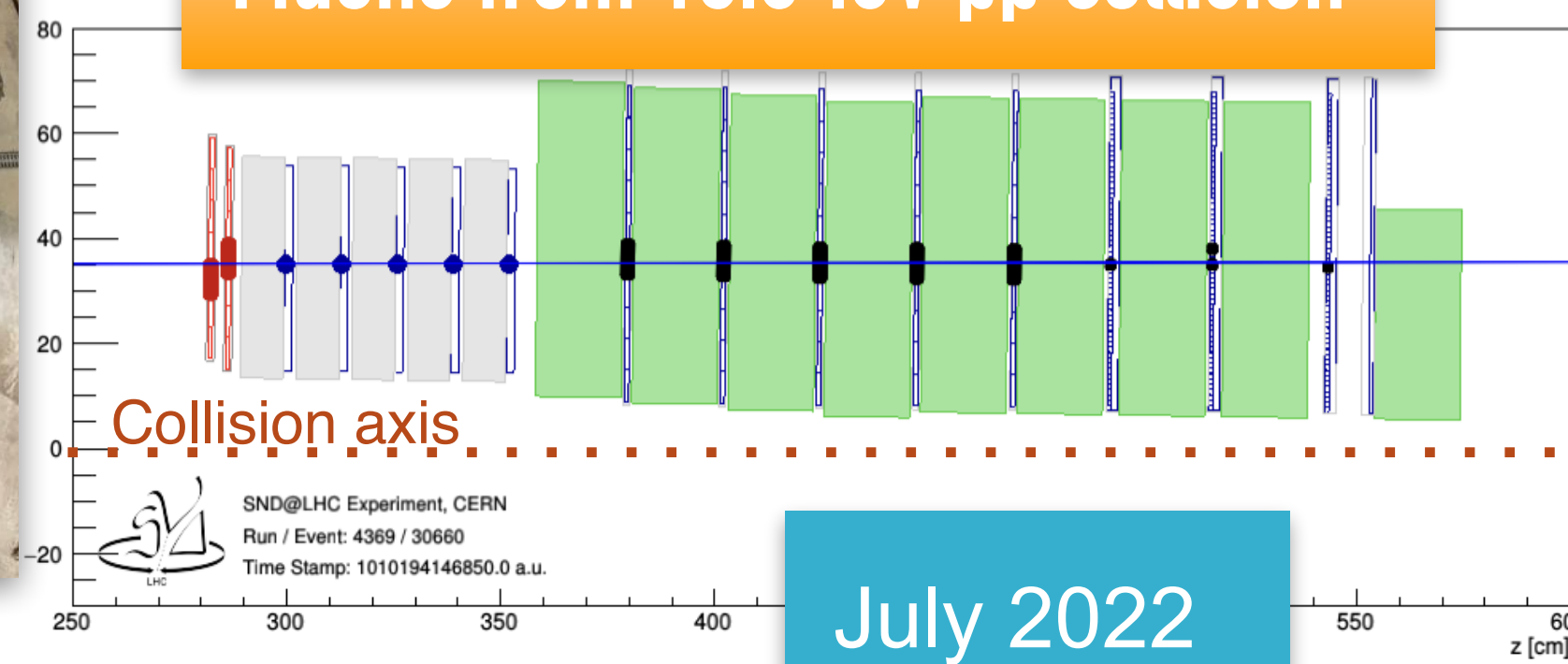

Observation of collider muon neutrinos

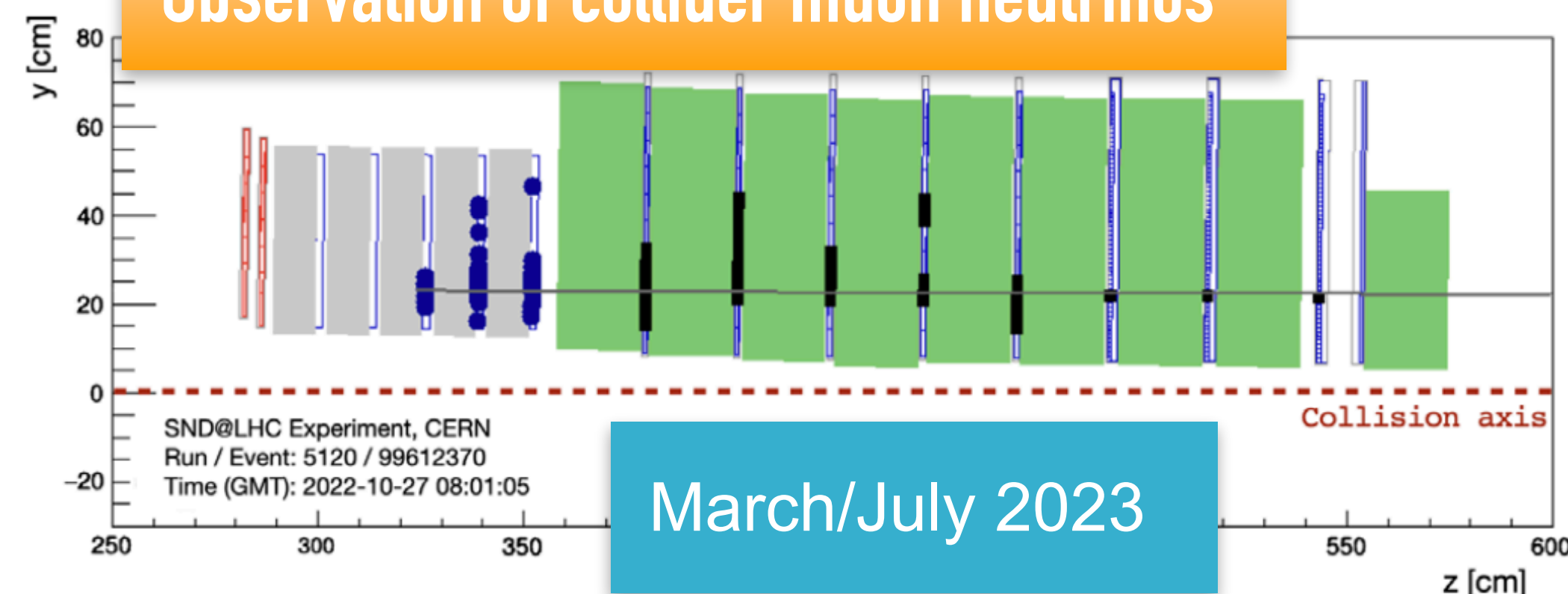

March 2022

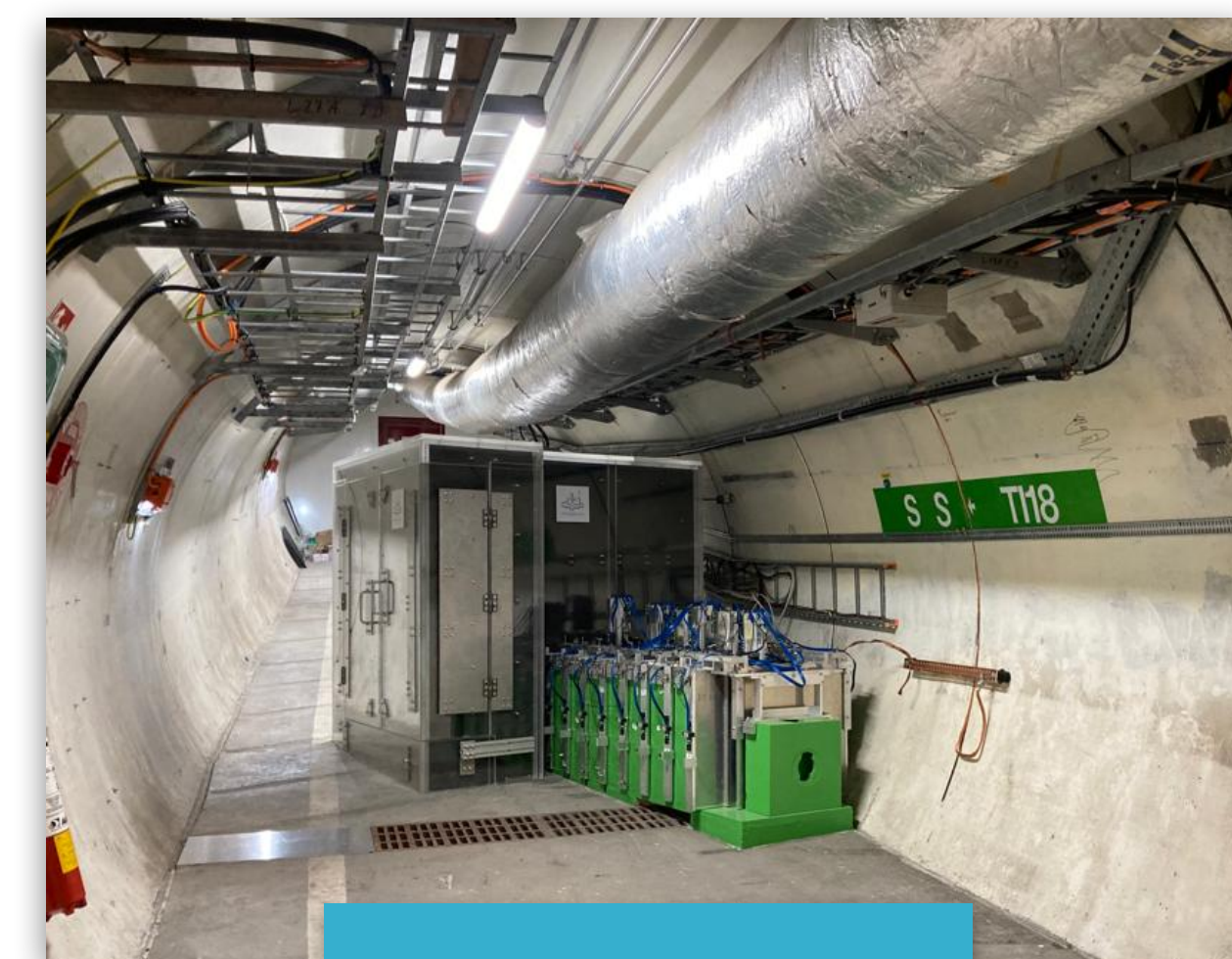

ν_μ — collider muon neutrino

paper in preparation
PhD thesis (GS)

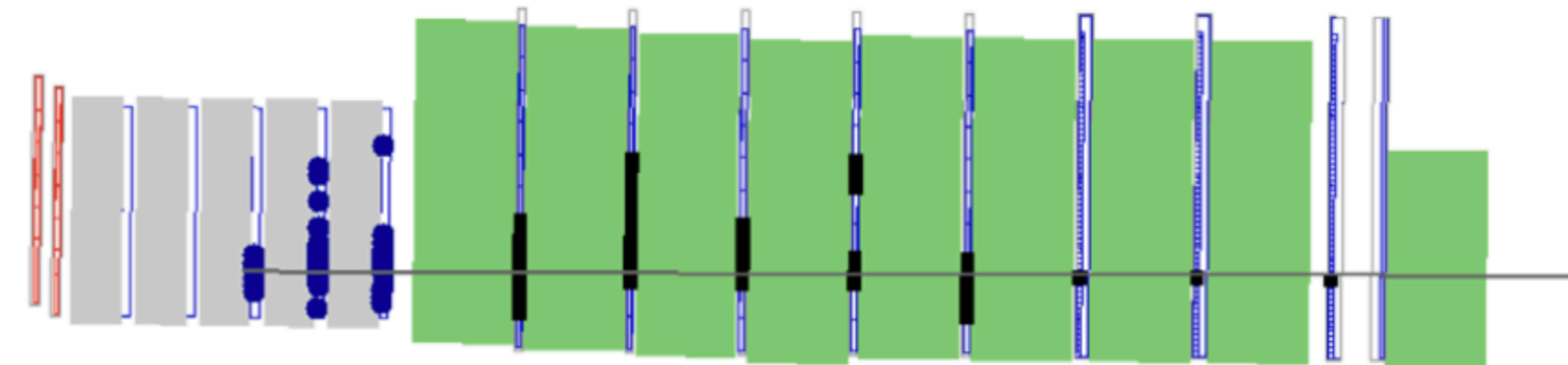
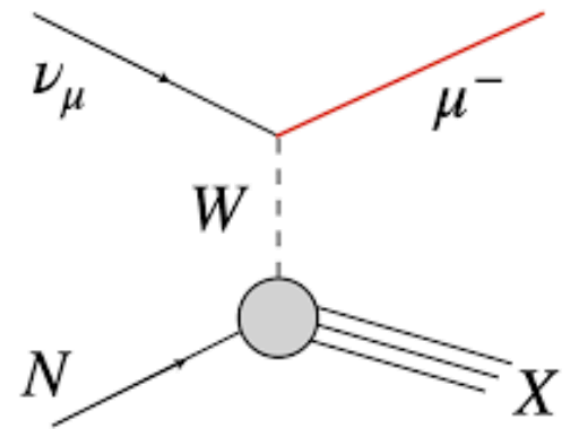

Preliminary

Number of events expected in 68.6 fb⁻¹

- Signal: 24 ⁺¹⁰₋₉ (prod) ⁺²₋₈ (sel)
- Background: 5.0 ± 1.1
 - Entering muons: 4.7 ± 1.1
 - Neutral hadrons: 0.3 ± 0.1

Number of events observed: 31

Following the **observation** (PRL 134 (2025) 23, with 2022 data), explore enlarged dataset (2022+2023) and detector/analysis acceptance → Carrying out first full **measurements**.

Measurement of ν_μ hadronic energy

Measurement of μ angle

Measurement of ν_μ -N cross-section

Preliminary

The nuclear cross section averaging the (anti)neutrino energies:

- Expected: 34 × 10⁻³⁵ cm²
- Measured: 37 ⁺²⁴₋₁₂ × 10⁻³⁵ cm²

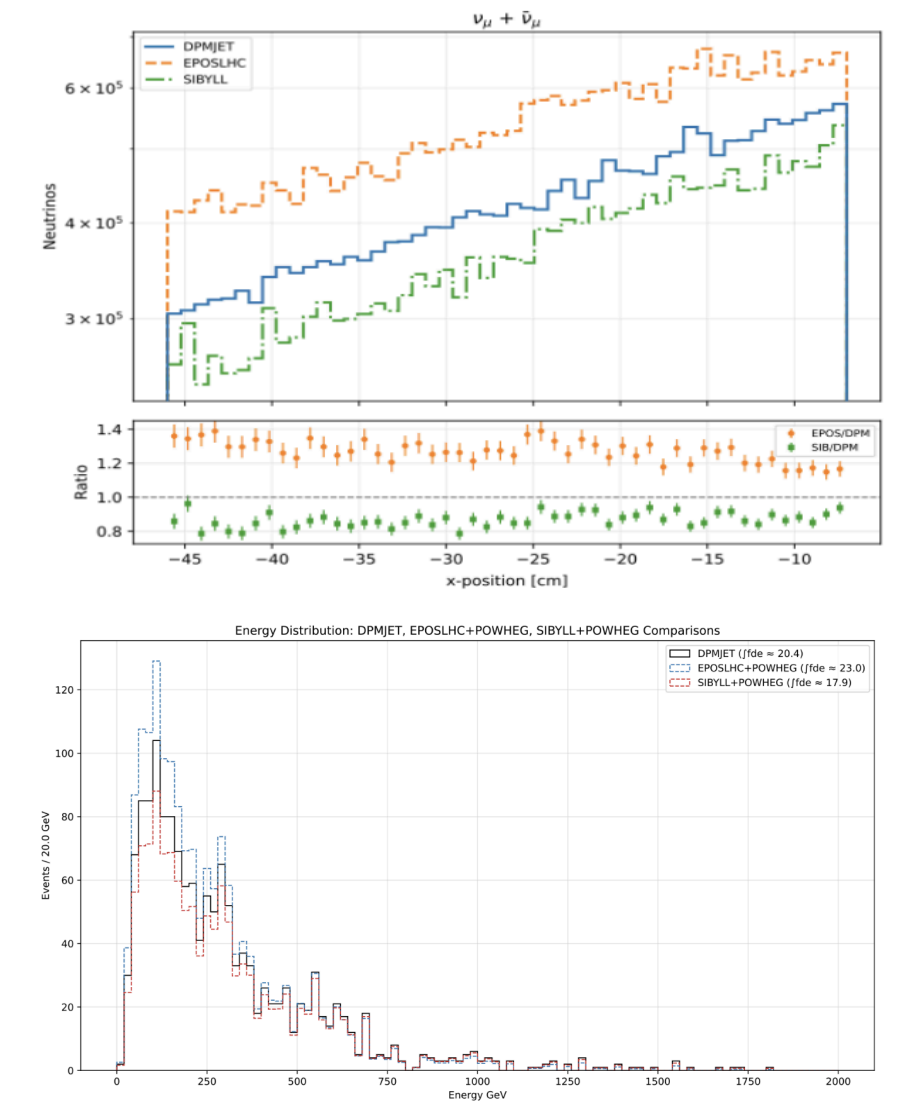
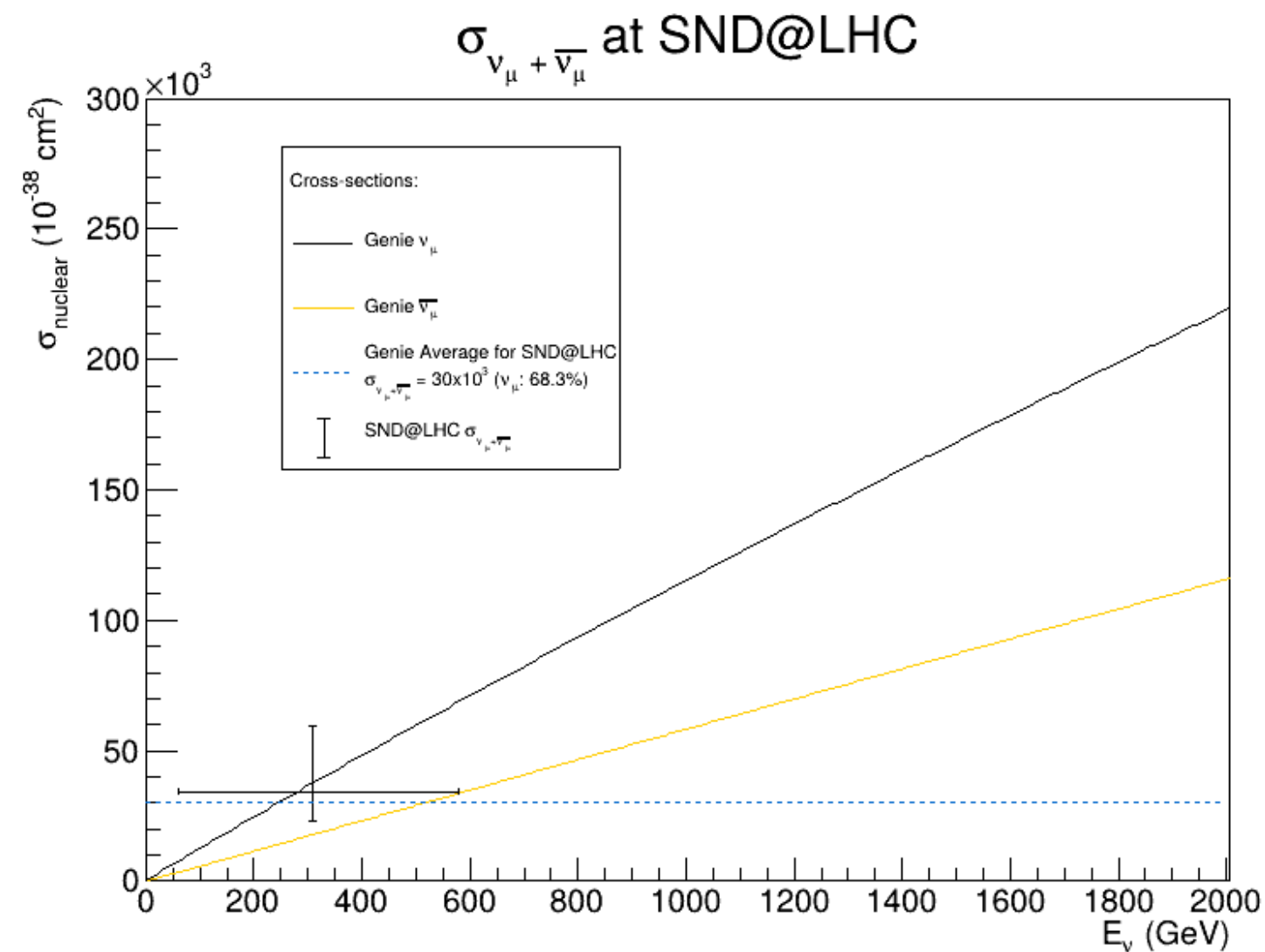
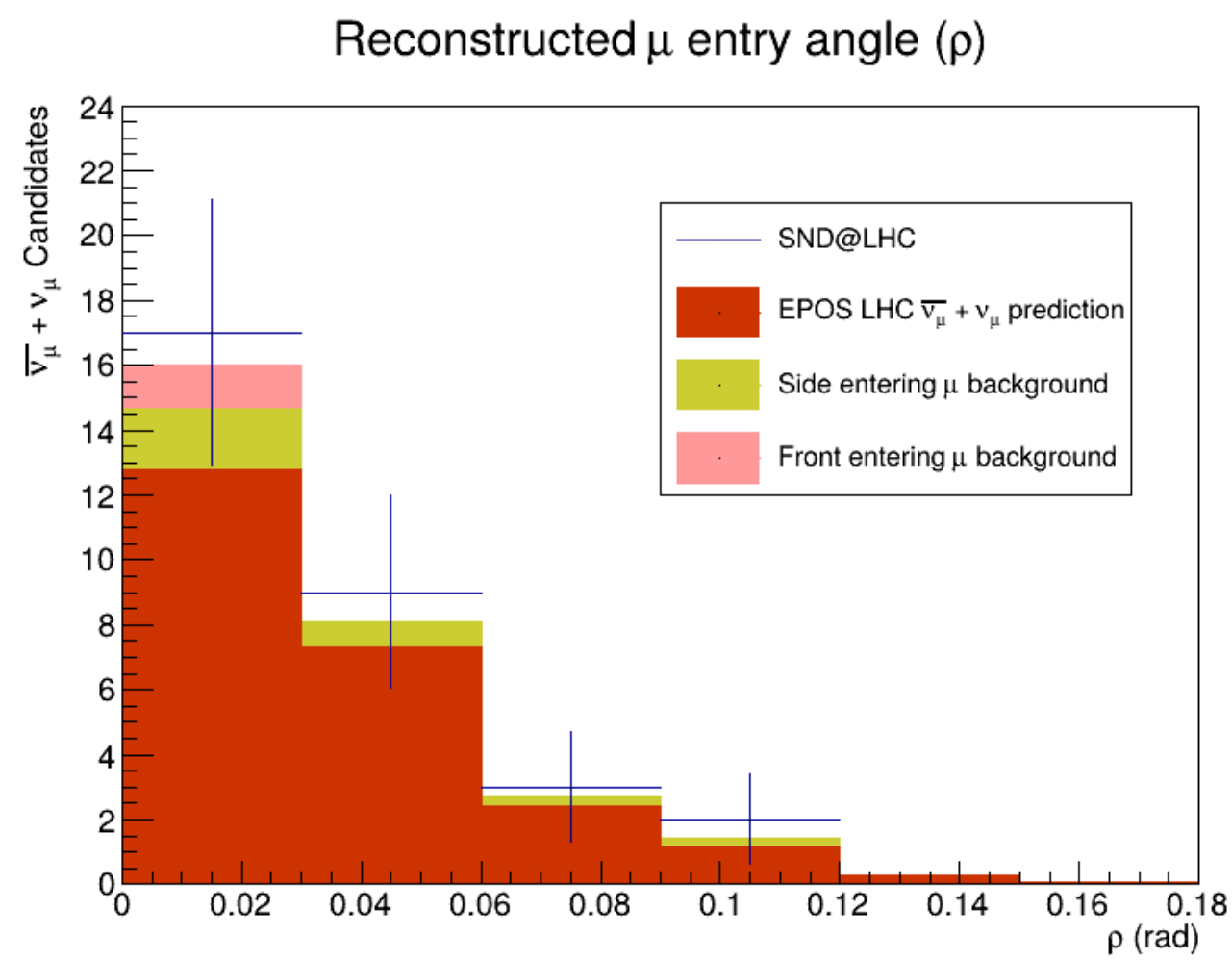
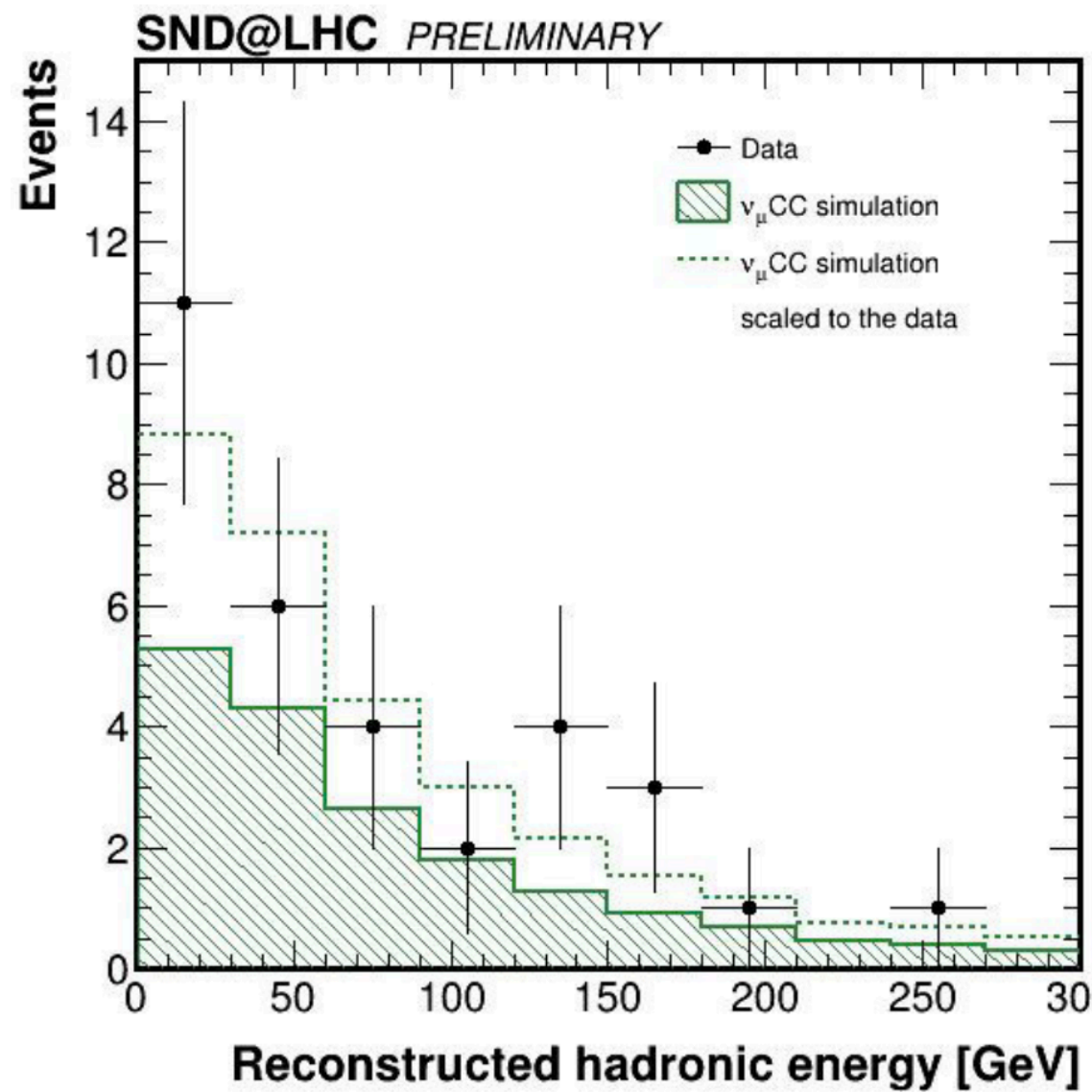

exploring zero- μ and two- μ events

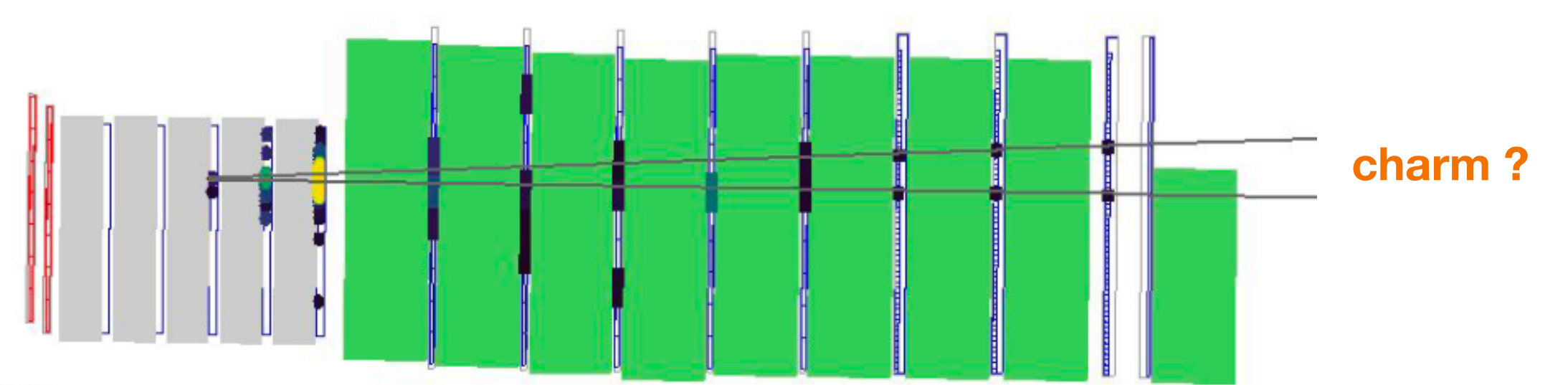
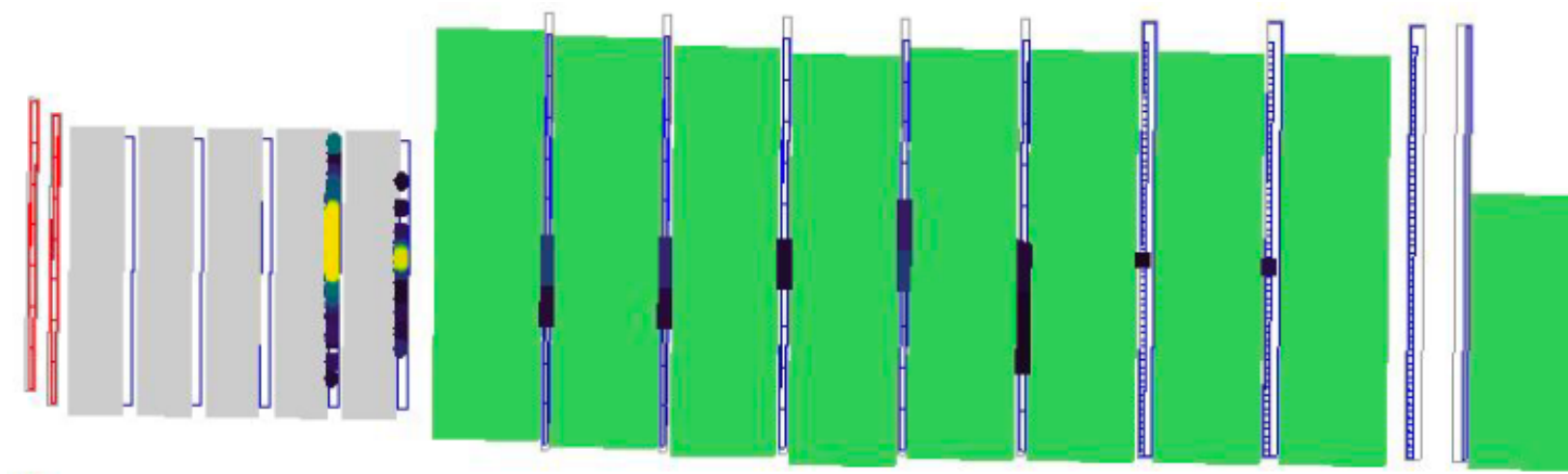

charm ?

Observation of $\nu_0\mu$ interactions

PHYSICAL REVIEW LETTERS 134, 231802 (2025)

[arxiv](#), [doi](#)

(CV)

Observation of Collider Neutrinos without Final State Muons with the SND@LHC Experiment

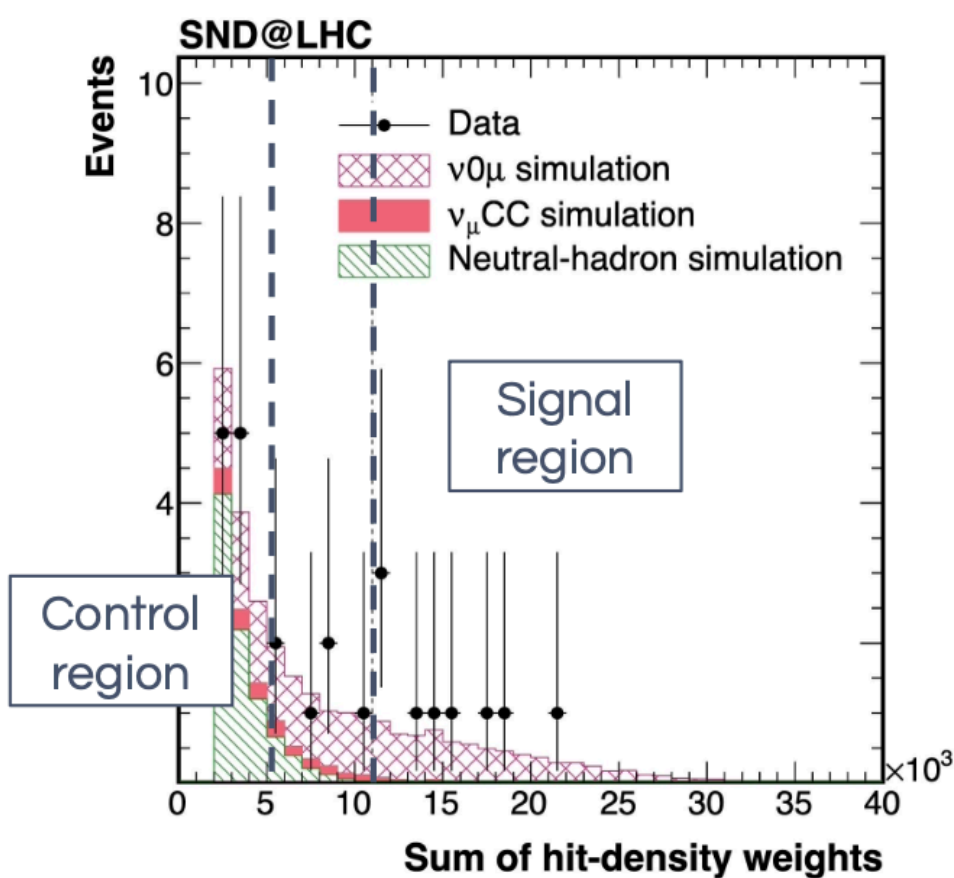

2022 + 2023 dataset (69 fb⁻¹)

Number of events observed: 9
Observation significance: 6.4 σ

ν_e CC observation significance: 3.7 σ

2022 + 2023 + 2024 dataset (171 fb⁻¹)

Observed events: 19 (expected: 19 \pm 5)
Significance binned (unbinned)
Expected: 4.5 σ (3.8 σ)
Observed: 2.7 σ (3.6 σ) *Preliminary*

Search for ν_e CC interactions

explore shower-like ν -events

- 2022 + 2023 + 2024 data (171 fb⁻¹)

PhD thesis (RB)

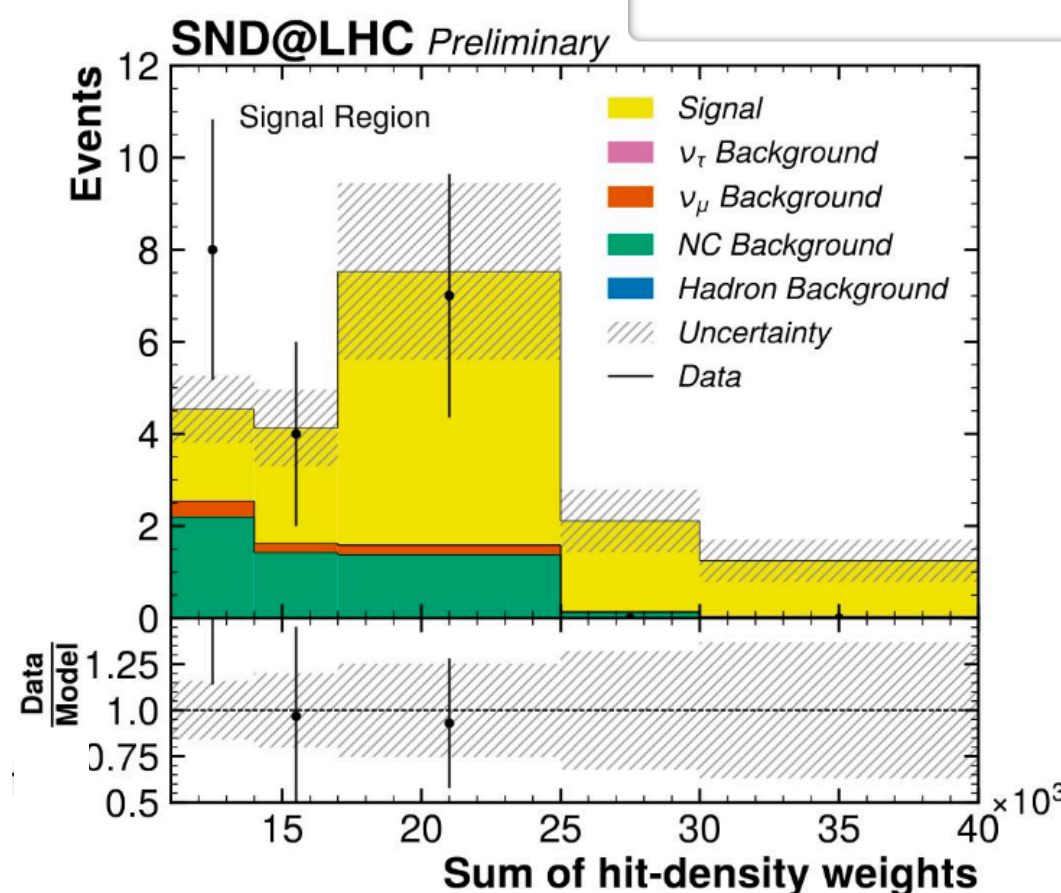

Search for new particles (Dark Higgs)

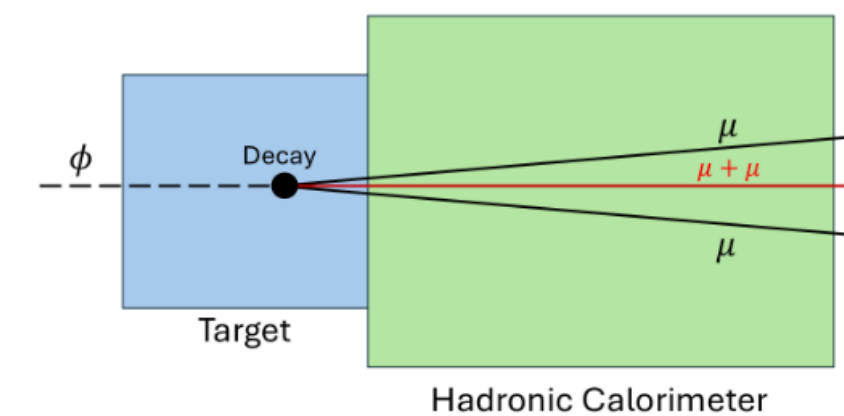

LLP signature:
DH \rightarrow $\mu\mu$ (collimated)

MSc thesis (HS)

[CERN-THESIS-2024-307](#)

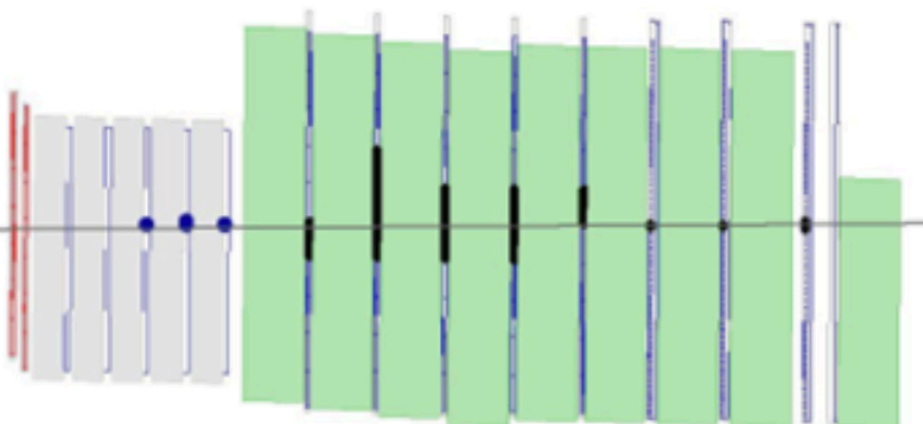
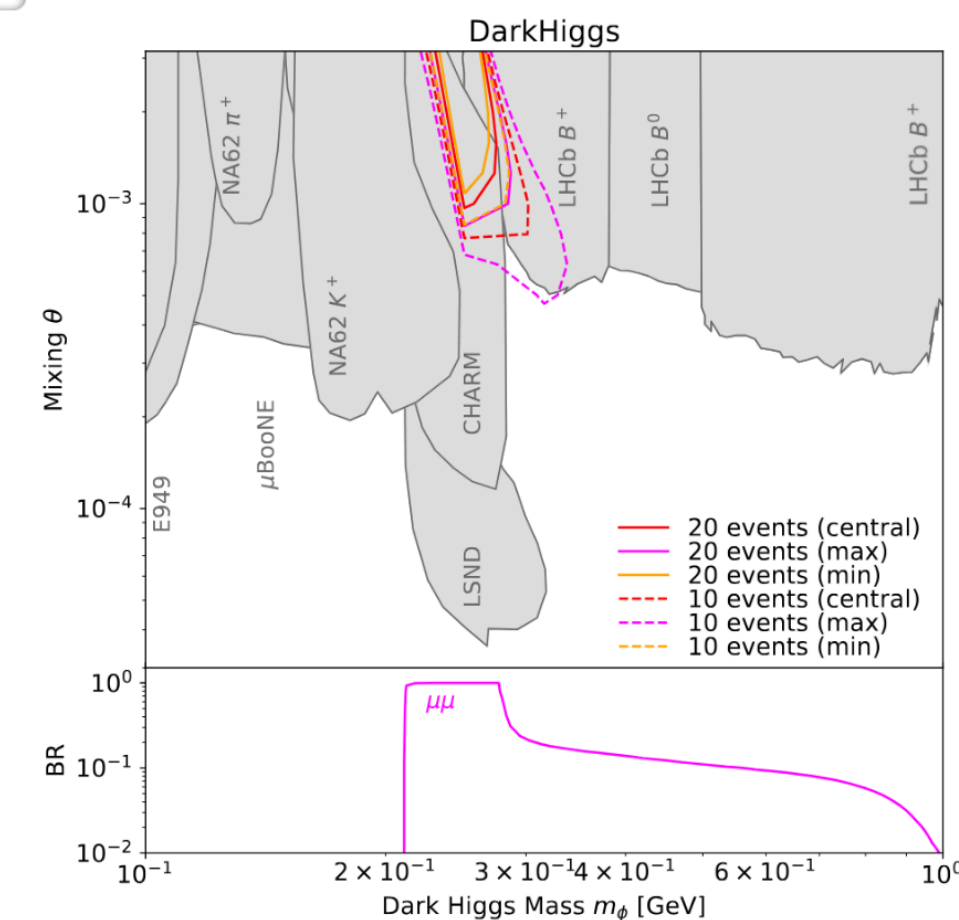

LIP-STUDENTS-25-25

Search for Dark Higgs with SND@LHC

Rodrigo Castanheira^{1,a}
¹Instituto Superior Técnico

clear evidence of ν_e component in the electronic detector data

detector calibration

HCal energy calibration

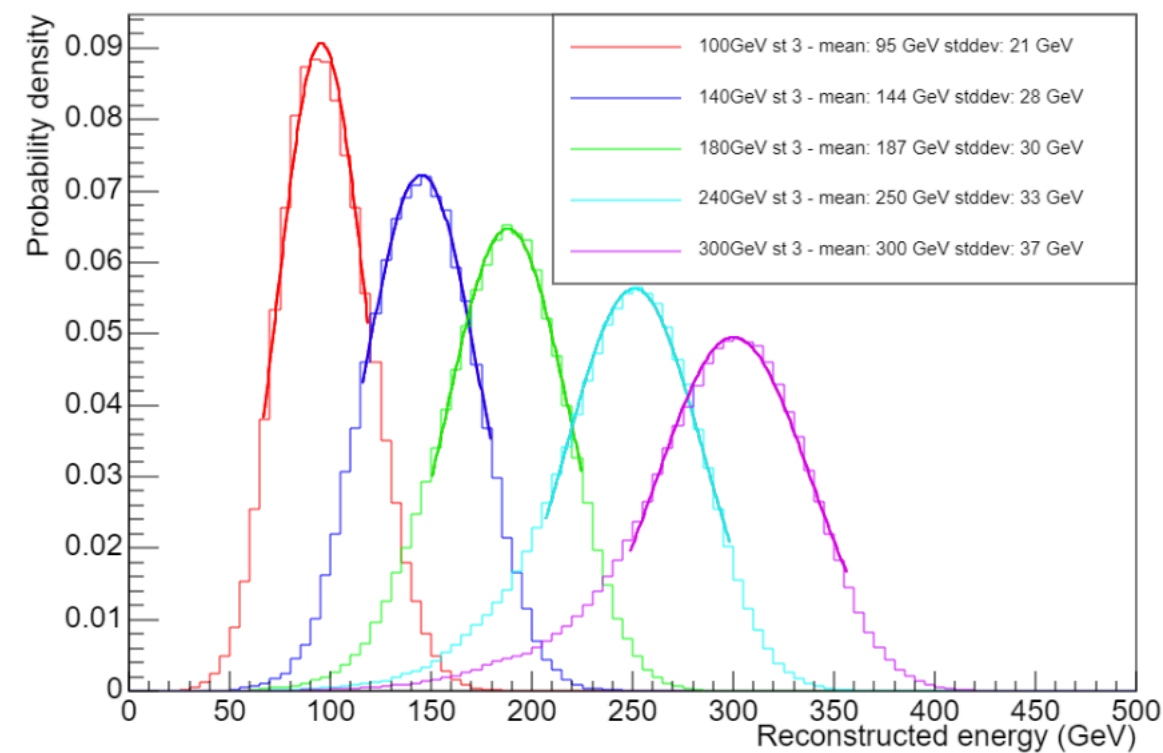

π beams
100 GeV
 $\sigma \sim 10\%$
300 GeV
 $\sigma \sim 12\%$

JINST, 2504.01716

Jinst

PUBLISHED BY IOP PUBLISHING FOR SISSA MEDIALAB

RECEIVED: April 7, 2025
REVISED: September 10, 2025
ACCEPTED: October 4, 2025
PUBLISHED: October 22, 2025

Studies of hadronic showers in SND@LHC



ABSTRACT: The SND@LHC experiment was built for observing neutrinos arising from LHC pp collisions. The detector consists of two sections: a target instrumented with SciFi modules and a hadronic calorimeter/muon detector. Energetic νN collisions in the target produce hadronic showers. Reconstruction of the shower total energy requires an estimate of the fractions deposited in both the target and the calorimeter. In order to calibrate the SND@LHC response, a replica of the detector was exposed to hadron beams with 100 to 300 GeV in the CERN SPS H8 test beam line in Summer 2023. This report describes the methods developed to tag the presence of a shower, to locate the shower origin in the target, and to combine the target SciFi and the calorimeter signals so to measure the shower total energy.

2025

Measuring the muon flux

LHC Luminosity (arbitrarily normalized) compared with RPC trigger rate

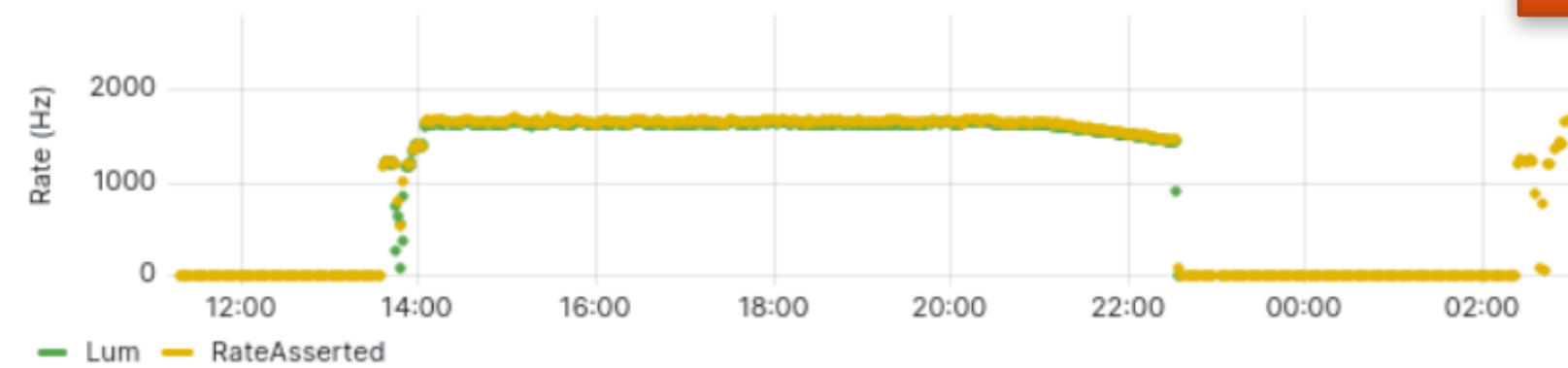

sRPC operating 24/7 for 800 days

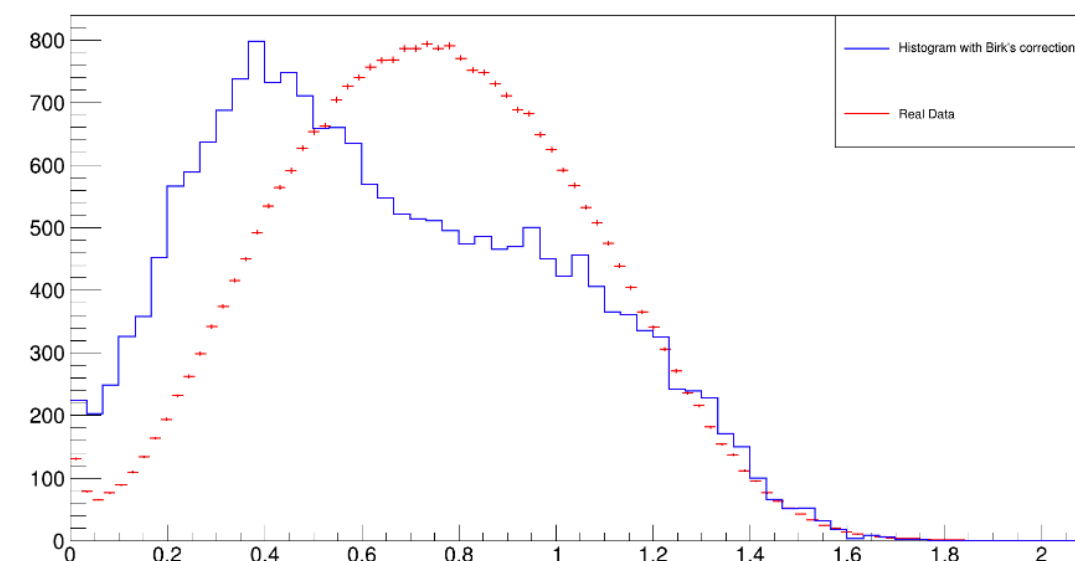

with LIP's sRPC (sealed RPC detector)

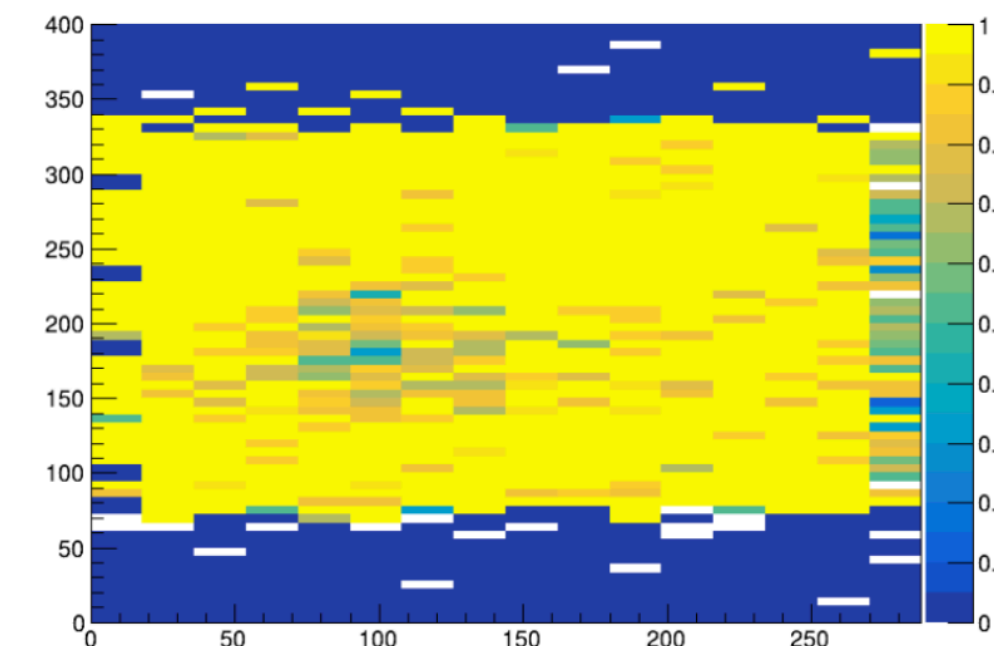

first look into simulation

Preliminary

Flux ($fb\ cm^{-2}$)	Cut area (30x21)
Real flux	1.01×10^5
Simulated flux	$(1.7 \pm 0.05) \times 10^5$

Energy Calibration of the SND@LHC and Search for the Dark Higgs LIP Summer Internships 2025

João Galhardo Rodrigo Castanheira

Supervisors:
Cristóvão Vilela
Nuno Leonardo

Measurement of Muon Flux at the LHC using the sRPC detector

LIP summer internship program 2025

João Goulão
Rafael Fernandes

Supervisors:
Cristóvão Vilela
Nuno Leonardo

5th September, 2025



towards HL-LHC & beyond

CERN-LHCC-2024-007 / LHCC-I-040
11/04/2024

AdvSND The Advanced Scattering and Neutrino Detector at High Lumi LHC

2024/4

Letter of Intent

SND@LHC Collaboration

2024/9

Addendum to the AdvancedSND LoI

CERN-LHCC-2024-014 ; LHCC-I-040-ADD-1

CERN-LHCC-2025-004 / LHCC-P-026
10/03/2025

TECHNICAL PROPOSAL

SND@HL-LHC

2025/3

Scattering and Neutrino Detector in Run 4 of the LHC

SND@LHC Upgrade for the High-Luminosity LHC: Physics Reach and Installation Scenarios

The SND@LHC Collaboration^{a1}

¹Full authorlist supplied at the end of this article.

2026/2

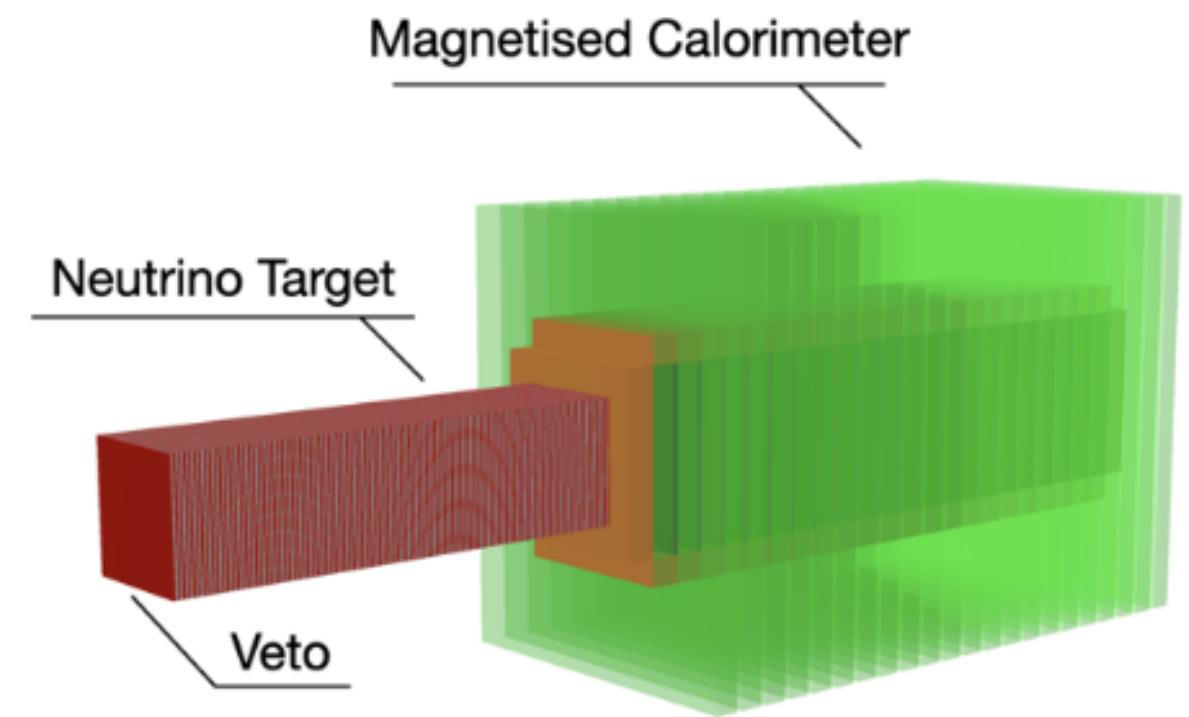

2013

CERN-SPSC-2013-024 / SPSC-EOI-010
October 8, 2013

Proposal to Search for Heavy Neutral Leptons at the SPS

CERN-SPSC-2019-049 / SPSC-SR-263
12/12/2019

2019

SHiP Experiment

COMPREHENSIVE DESIGN STUDY REPORT

SHiP Collaboration

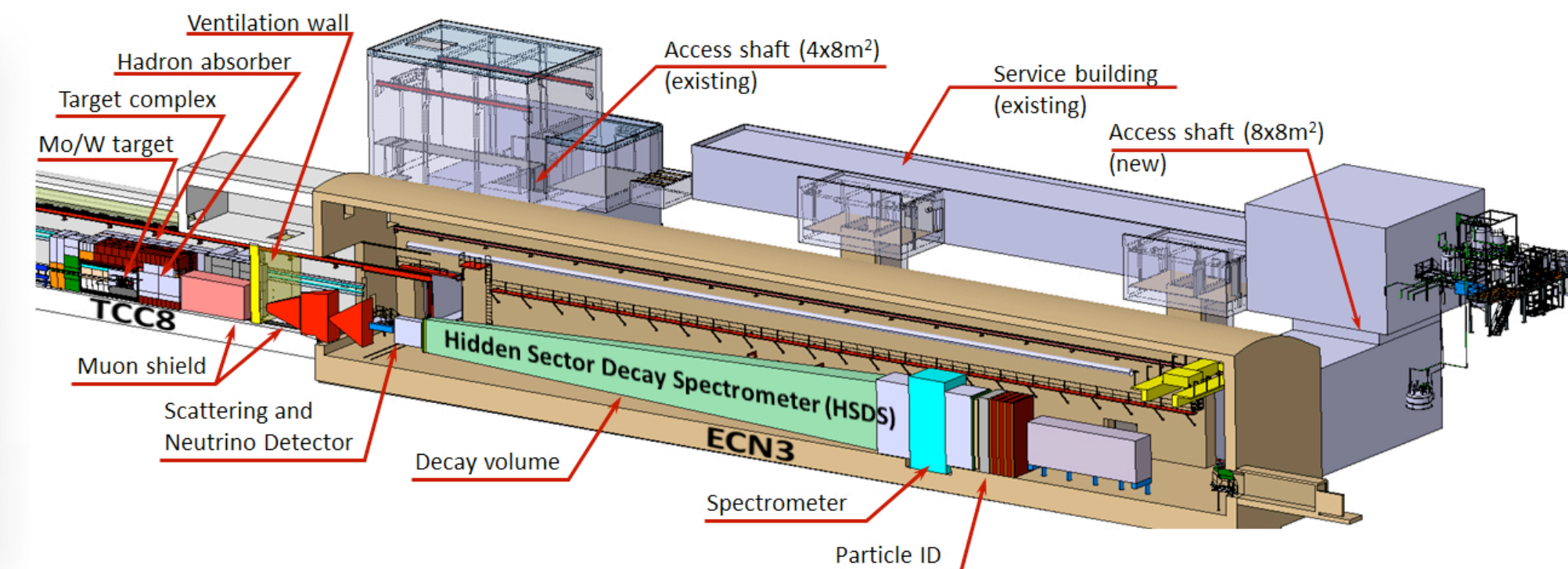

2015

CERN-SPSC-2015-017 (SPSC-P-350-ADD-1)

A facility to Search for Hidden Particles at the CERN SPS: the SHiP physics case



2022

CERN-SPSC-2022-032 / SPSC-I-258
7 November 2022

BDF/SHiP at the ECN3 high-intensity beam facility

Letter of Intent

¹BDF Working Group, SHiP Collaboration



2024

CERN-SPSC-2023-033 / SPSC-P-369
31 October 2023

BDF/SHiP at the ECN3 high-intensity beam facility

Proposal

SHiP Collaboration¹ with support from the BDF Working Group ²



2022

CERN-SPSC-2022-009
1 March 2022

Study of alternative locations for the SPS Beam Dump Facility

European strategy for particle physics '2026



inputs to the update process

Input from the SND@LHC collaboration to the 2026 Update to the European Strategy for Particle Physics

<https://arxiv.org/abs/2503.24233>

SND@LHC Collaboration

March 28, 2025

By observing collider neutrino interactions of different flavours, the SND@LHC and Faser experiments have shown that the LHC can make interesting contributions to neutrino physics. This document summarizes why the SND@LHC Collaboration intends to continue taking data at the High Luminosity LHC (HL-LHC).

The upgraded detector^[1] will instrument the regions of both the neutrino vertex and the magnetized calorimeter with silicon microstrips. The use of this technology will allow us to continue the physics program of the current SND@LHC detector with higher statistics. It will also offer new possibilities. For instance, the magnetization of the hadron calorimeter will enable the separation between neutrinos and antineutrinos. This could lead to the first direct observation of tau antineutrinos.

The use of ultrafast timing layers will enable triggers to be sent to ATLAS, potentially allowing the identification of the charm quark pair that produced the neutrino interacting in the detector. Such tagging of the neutrino source would fulfill Pontecorvo's original proposal of a tagged neutrino beam. The experiment will perform unique measurements with high energy neutrinos and will also provide a means to measure gluon parton distribution functions in a previously unexplored domain (Bjorken- $x < 10^{-5}$).

Furthermore, the technological advancements of the upgrade will provide experience that will be gained in the areas of operation and data taking for the HL-LHC in the design of the neutrino detector for the SHiP.



SHiP experiment at the SPS Beam Dump Facility

¹SHiP Collaboration & HI-ECN3 Project Team

<https://arxiv.org/abs/2504.06692>

Abstract

In 2024, the SHiP experiment, together with the associated Beam Dump Facility (BDF) under the auspices of the High Intensity ECN3 (HI-ECN3) project, was selected for the future physics exploitation of the ECN3 experimental facility at the SPS. The SHiP experiment is a general-purpose intensity-frontier setup designed to search for physics beyond the Standard Model in the domain of Feebly Interacting Particles at the GeV-scale. It comprises a multi-system apparatus that provides discovery sensitivity to both decay and scattering signatures of models with feebly interacting particles, such as dark-sector mediators, both elastic and inelastic light dark matter, as well as millicharged particles. The experiment will also be able to perform both Standard Model measurements and Beyond Standard Model searches with neutrino interactions. In particular, it will have access to unprecedented statistics of tau and anti-tau neutrinos. The construction plan foresees commissioning of the facility and detector, and start of operation in advance of Long Shutdown 4, with a programme of exploration for 15 years of data taking. By exploring unique regions of parameter space for feebly interacting particles in the GeV/c² mass range, the SHiP experiment will complement ongoing searches at the LHC and searches for dark matter.

Document

https://indico.lip.pt/event/1924/sessions/998/attachments/4939/8050/Hidden_Particles_SHiP.pdf

Collider Neutrinos | SND@LHC

The recent first direct observation of neutrinos at the LHC, achieved by FASER and SND@LHC, opens the window for the exploration of Neutrino Physics at colliders. Portugal has a major involvement in the SND@LHC experiment, steering both physics analyses and detector improvements. The exploitation of the potential of the experiment some key detector improvements will largely extend the physics reach of the upgrade of both in neutrino physics and in BSM searches. We strongly support the upgrade of the SND@LHC detector, that will allow the exploration of neutrino physics during the HL phase of the LHC.

Cor

¹Con

The SND@LHC experiment is a newcomer to the field since the last ESPPU (2020). It has been approved in 2021, started data taking in 2022 at the start of LHC Run3, and delivered first physics results in 2023. The physics objective is the detection of high-energy neutrinos produced by the LHC to study neutrino properties and to probe heavy flavor production in the very forward region. The collaboration recently reported the observation of collider neutrinos, demonstrating the effectiveness of such compact detectors and paving the way for new physics studies with higher statistics.

The Portuguese group is a founding member of SND@LHC, having been centrally involved in the construction and calibration of the detector and in the physics exploration of the data collected. Group members led the observation of collider muon neutrinos, are carrying out first searches for BSM particles (FIPs), and have been entrusted by the collaboration with central coordination roles (Physics Coordination, Editorial Board, Upgrade). The group has deployed a new sub-detector, based on the novel sealed-RPC technology, for extended muon-flux background measurements, and group members have a leading involvement in the definition of the upgraded detector for HL-LHC.

The design of the detector for operating during the HL-LHC phase involves novel precise instrumentation of the neutrino target based on silicon sensors. Minimal civil engineering will be needed to lower the tunnel floor to fit the slightly larger upgraded detector. The experiment will use silicon strip detector modules inherited from the CMS outer barrel tracker. It also foresees high-precision timing layers, based on scintillator or RPC technology, that may be explored to correlated neutrino-like events with ATLAS data via a dedicated trigger.

The upgraded detector will further extend the scope of direct BSM searches along with unique heavy flavor measurements in the forward region not accessible by other experiments. Collaboration exists in detector R&D in particular for the SHiP experiment, with a highly complementary physics case.

from the Briefing book (2025/12)

Neutrinos at higher energy, from a few GeV up to multiple TeV, are observed in atmospheric neutrino detectors and in neutrino telescopes. A new approach in this high-energy domain has been demonstrated by the FASER [ID23] and SND@LHC[ID63] experiments. These experiments detect the neutrinos produced in proton-proton collisions at the LHC in the very forward direction of the ATLAS experiment, benefiting from a relatively well-known neutrino flux compared to astrophysical neutrinos. Updates of these experiments in the HL-LHC era should collect very large neutrino samples of all flavours. SND@LHC also aims to demonstrate detector technology that could be implemented in the future SHiP beam-dump experiment, which will collect unprecedented number of neutrino interactions (notably of tau neutrinos) in the 10–100 GeV region. Further expansions of this programme are being proposed, including a new large-scale infrastructure at the LHC (FPF [ID19]), hosting several multi-ton detectors to collect millions of TeV neutrino events. Similar facilities are being studied for future hadron

from the Deliberation document (2026/04)

Non-collider physics

Substantial progress has also been made in non-collider physics. Experiments at CERN and other European institutes have significantly contributed to the important diversity of the particle physics programme. Through the approval of SHiP, a beam-dump experiment with high-intensity beams, CERN has renewed its commitment to a compelling programme complementary to the LHC.

https://indico.lip.pt/event/1924/sessions/998/attachments/4939/8050/Collider_Neutrinos_SND-LHC.pdf

Exploring Hidden Sector | SHiP

The Search for Hidden Particles experiment (SHiP) is a proposed a general-purpose intensity-frontier experimental facility for operating in beam-dump mode at the CERN SPS accelerator to search for feebly interacting GeV-scale particles. The SHiP detector is sensitive both to decay and scattering signatures of models with heavy neutral leptons, dark photons, dark scalars, axion-like particles, light dark matter and other feebly interacting particles (FIPs). First precision measurements of the tau neutrino will become accessible.

The previous Strategy Update (2020) stated that the study of the dark sector is well motivated from the physics point of view but a beam-dump facility would be difficult to fund within the CERN budget at the time. Since then, the BDF/SHiP collaboration demonstrated that the existing ECN3 experimental facility allows to implement the BDF facility at a fraction of the cost of the original proposal, without compromising the physics sensitivity. In 2023 CERN approved the high-intensity upgrade for ECN3, and selected SHiP in 2024 as the experiment for the physics exploitation of the facility. The collaboration has moved towards the preparation of the technical design report, while discussion with the funding agencies of the proponent and new institutes are being pursued for resourcing the detector construction from 2027.

Portugal has a longstanding search program for FIPs and measurements in neutrino physics. The Portuguese group has performed physics sensitivity studies and deployed a sub-detector prototype based on the RPC technology, with high efficiency and timing capability. We are tasked in the SHiP Proposal for delivering a critical sub-detector, for background vetoing in the decay vessel, and have initiated additional involvement in the preparation of the scattering and neutrino detector (SND). Our physics and detector activities in SHiP benefit from and significantly extend our current involvement in the SND@LHC experiment.

We strongly support the effort of the SHiP collaboration to ensure the detector can be constructed in a timely manner, to be ready for data-taking in 2032, and delivering a successful and impactful physics program over the ensuing 15 years (beyond HL-LHC).

Towards the future detectors

SND@HL-LHC

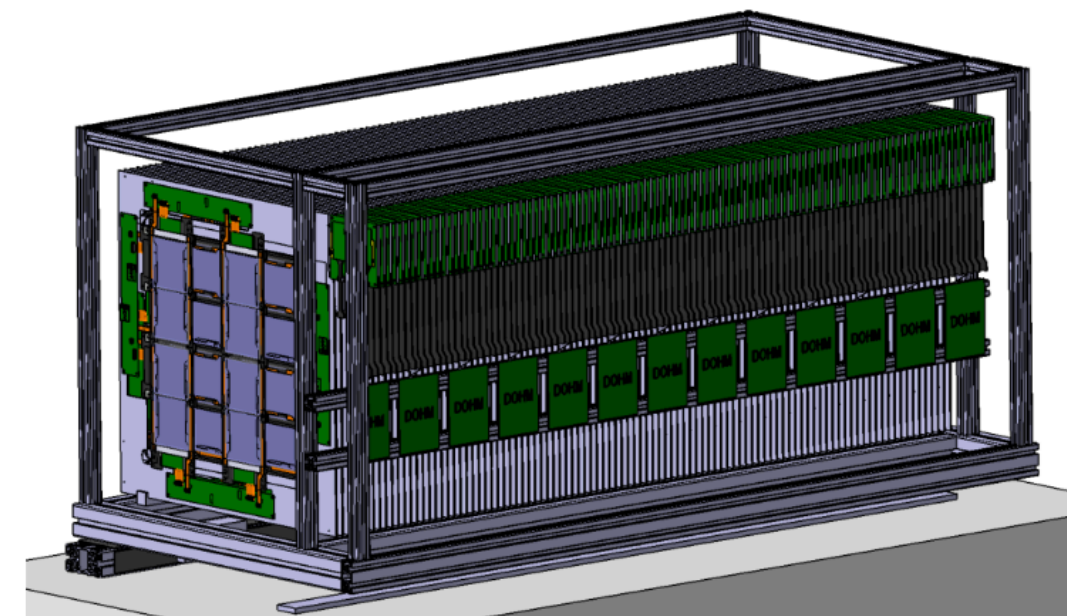
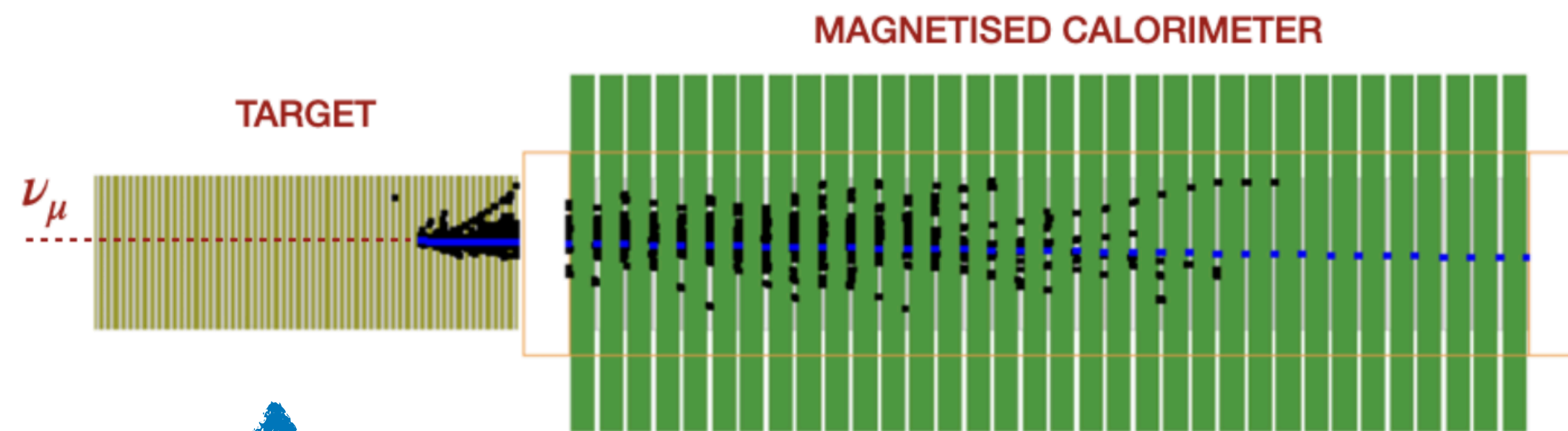

Silicon target tracker

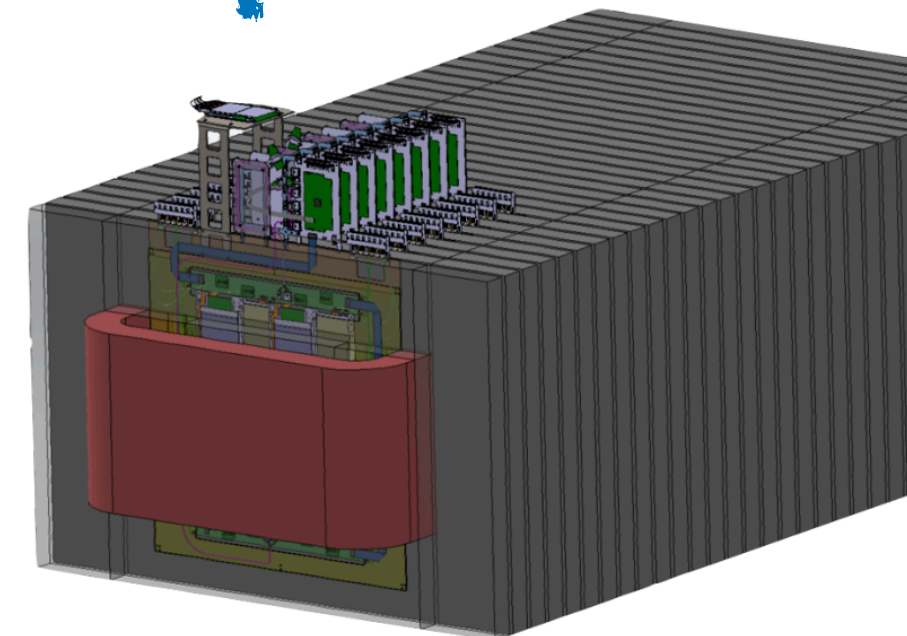

Silicon calorimeter

SHiP @ECN3

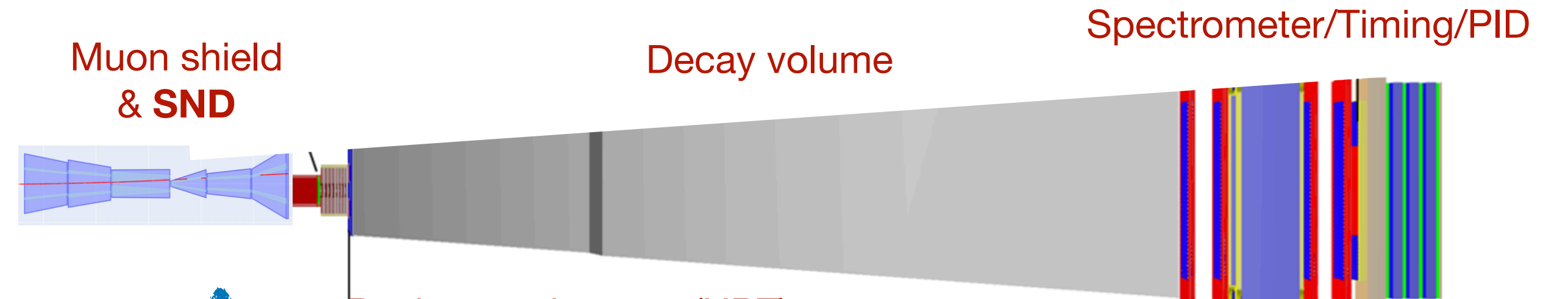

Background tagger (UBT)

- ☞ SHiP being re-optimized towards TDR / construction phase
 - ⇒ varying conditions and sub-detector specifications
 - ⇒ UBT RPC-based proposal (by LIP) being *replaced*
- ☞ SND to be now installed *within* the Muon shield system

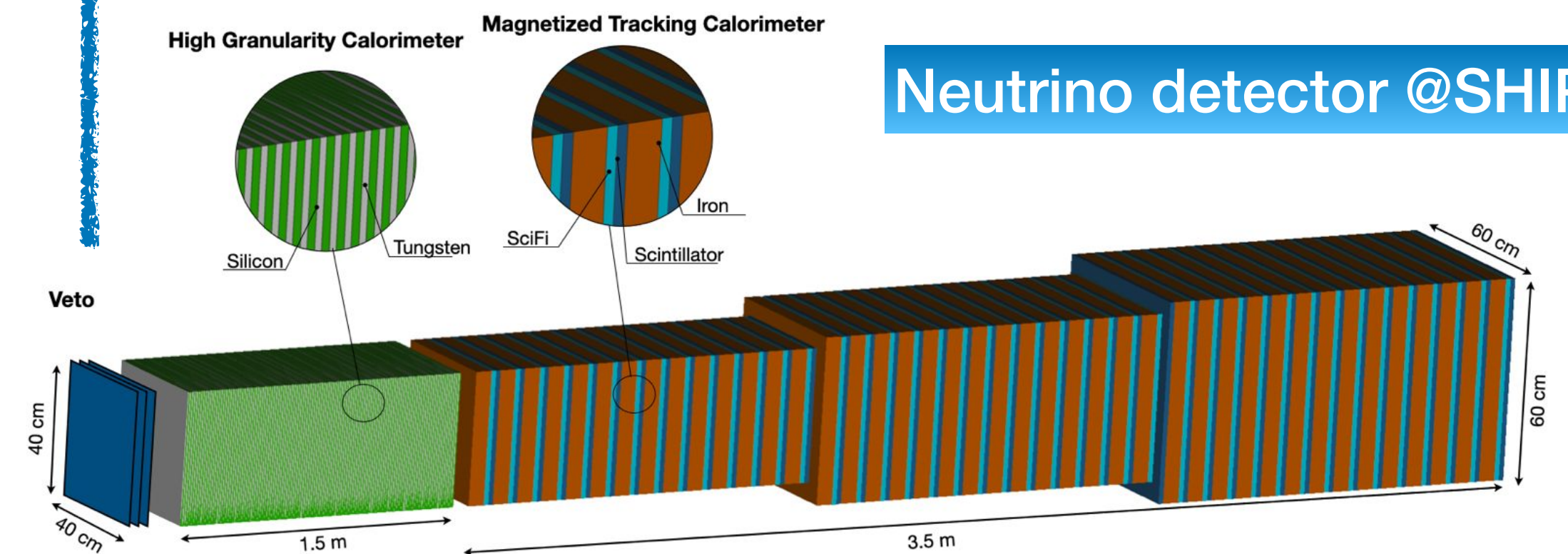

Neutrino detector @SHiP

• LIP involved in (Si-based) **Target** and **Calorimeter** and **Timing**/trigger detectors, exploring **SND-SHiP synergy**

Silicon target

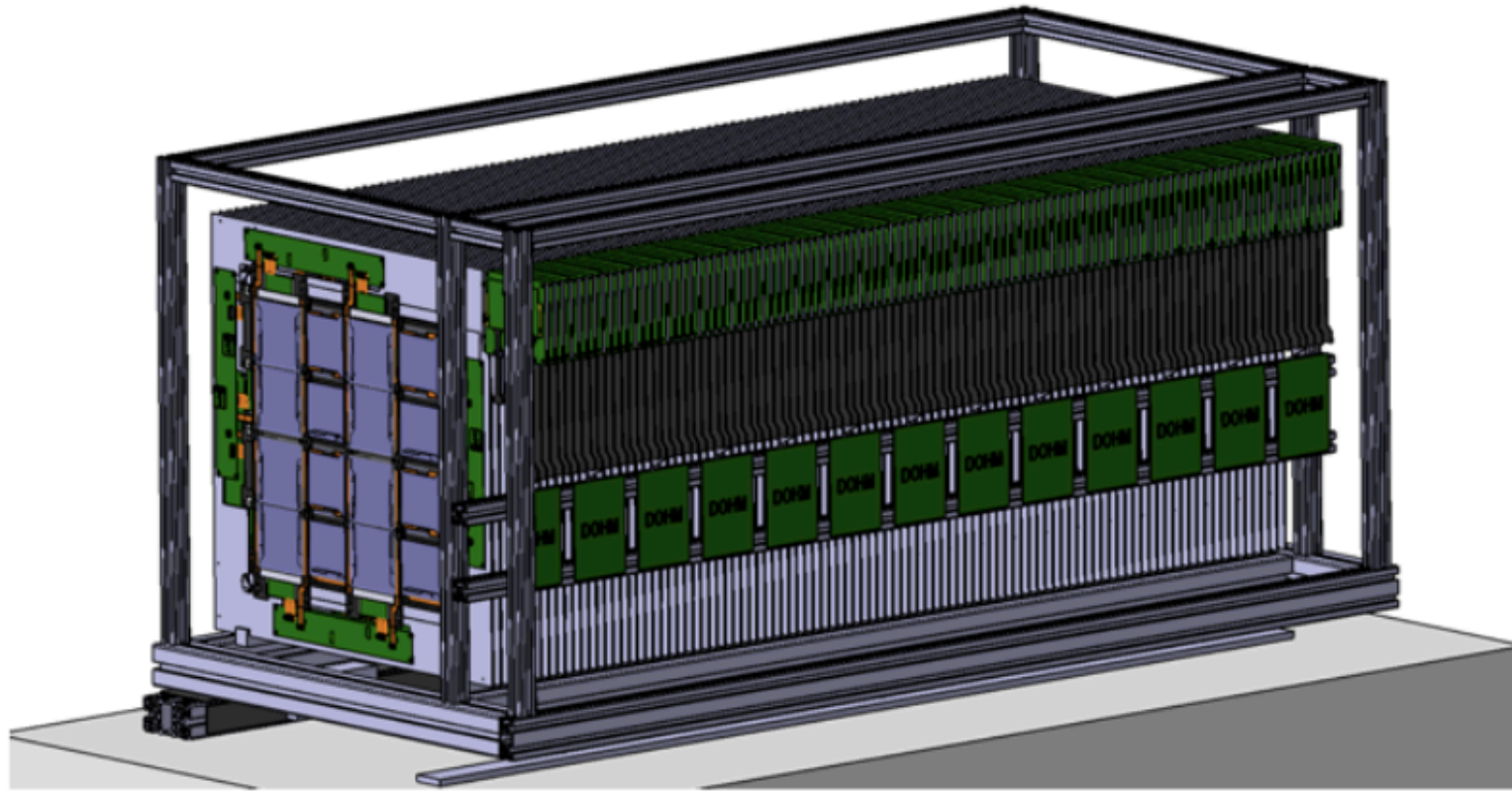

preparations for test-beam

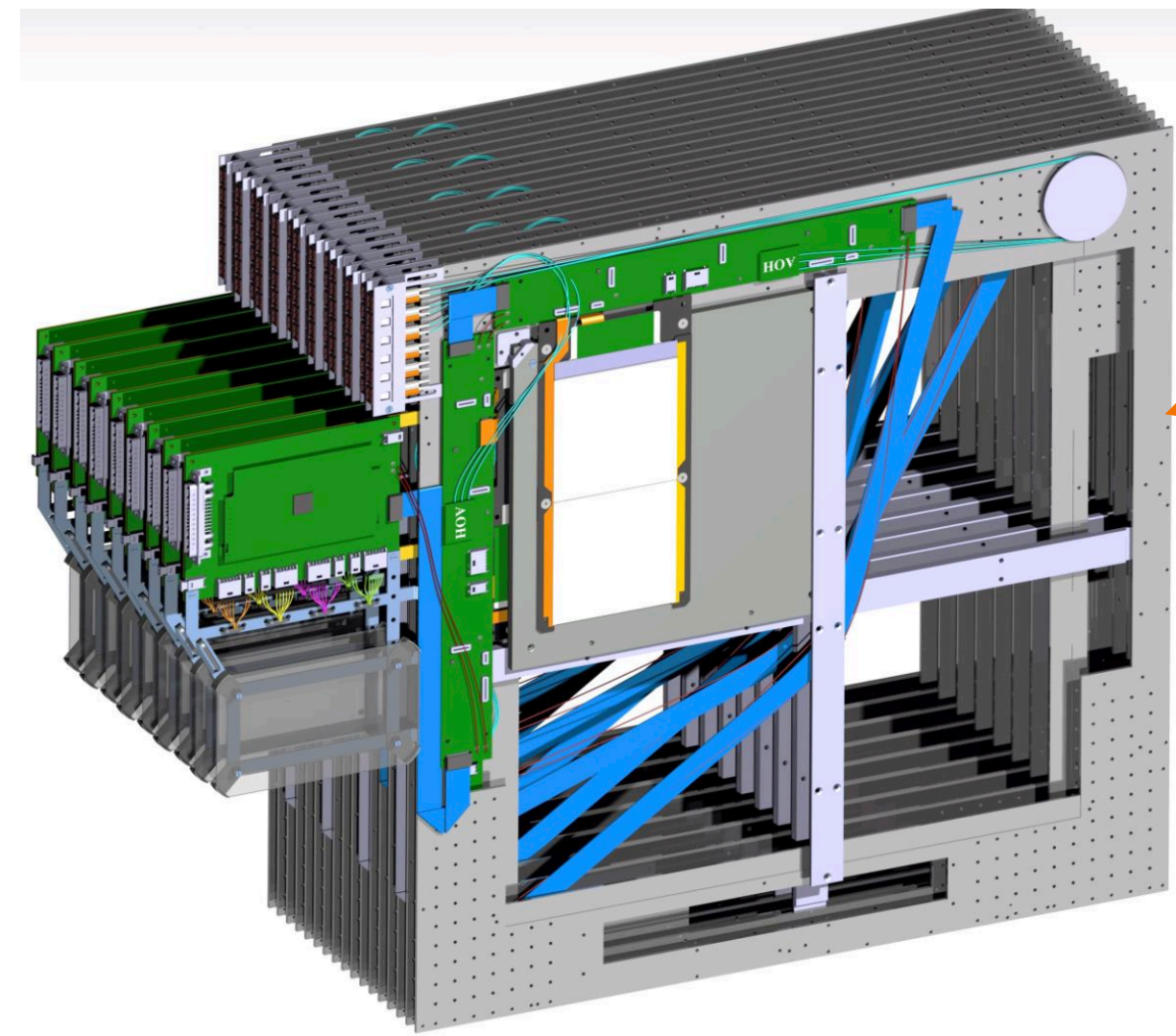

productions @LIP (LL)

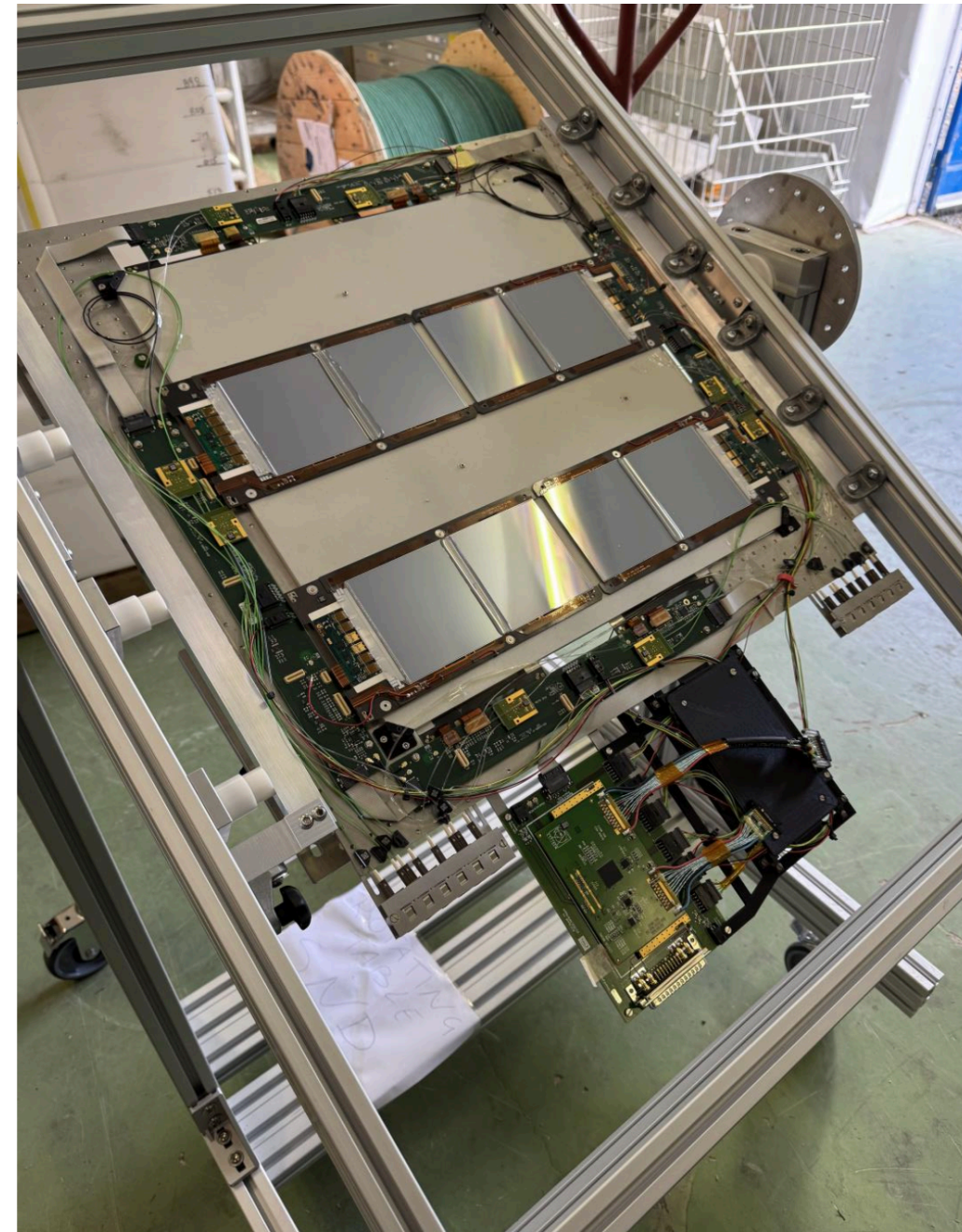
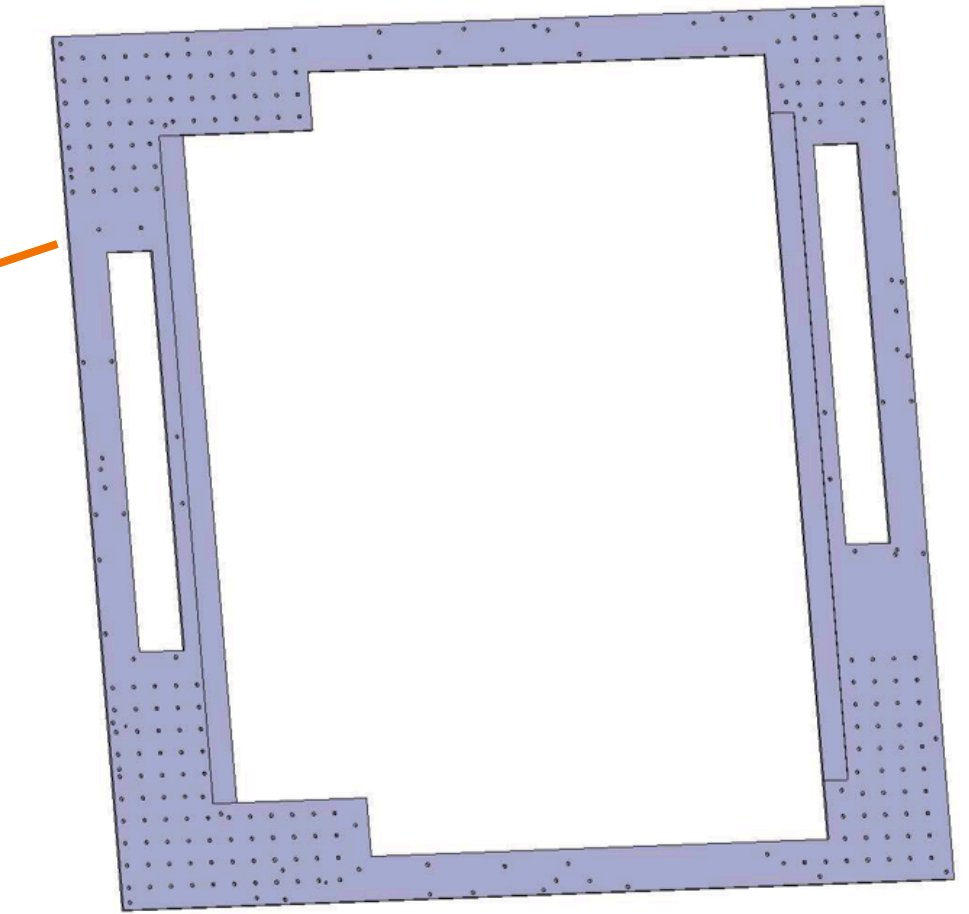

Si-strip sensors from re-purposed CMS TOB

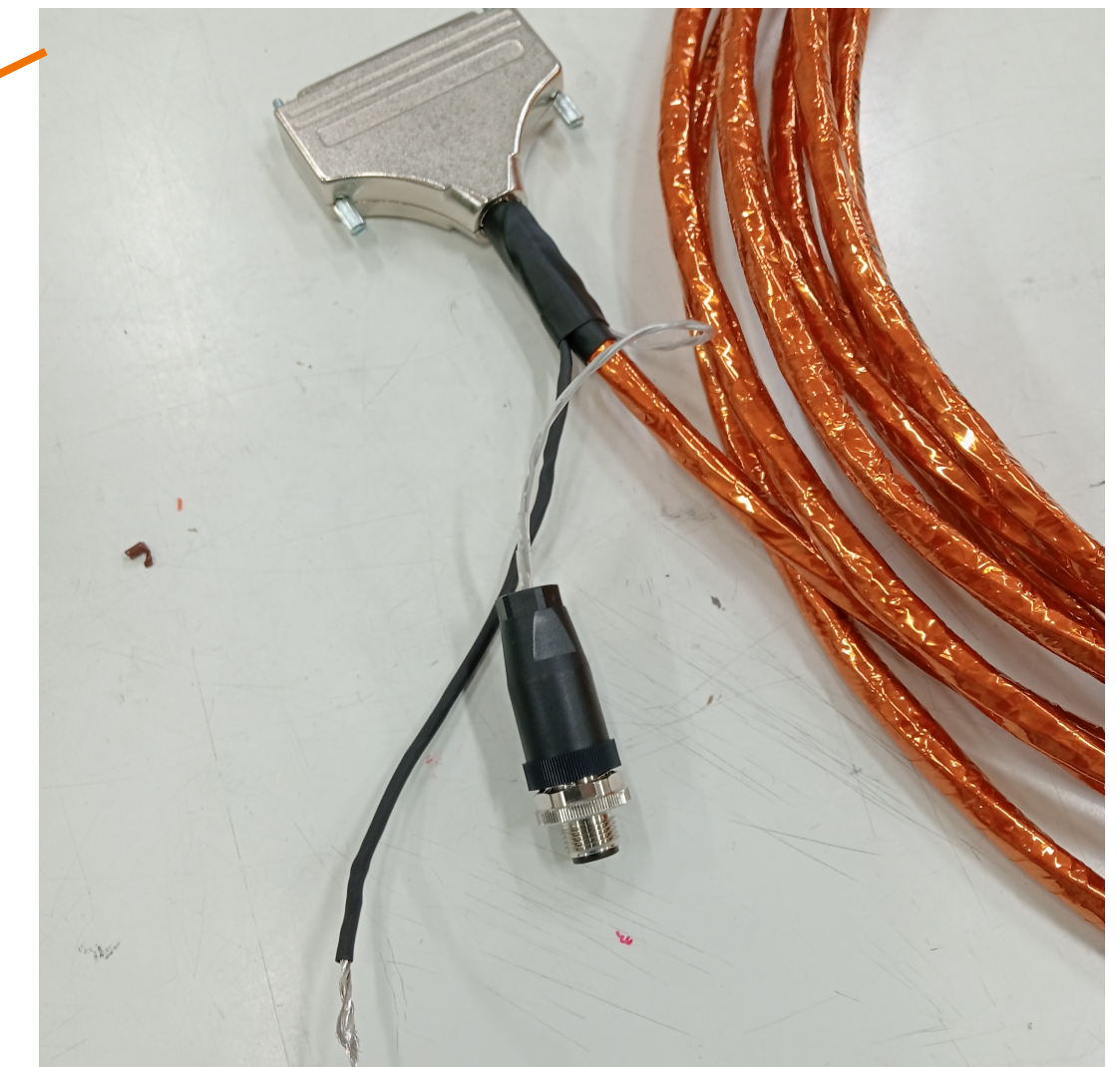
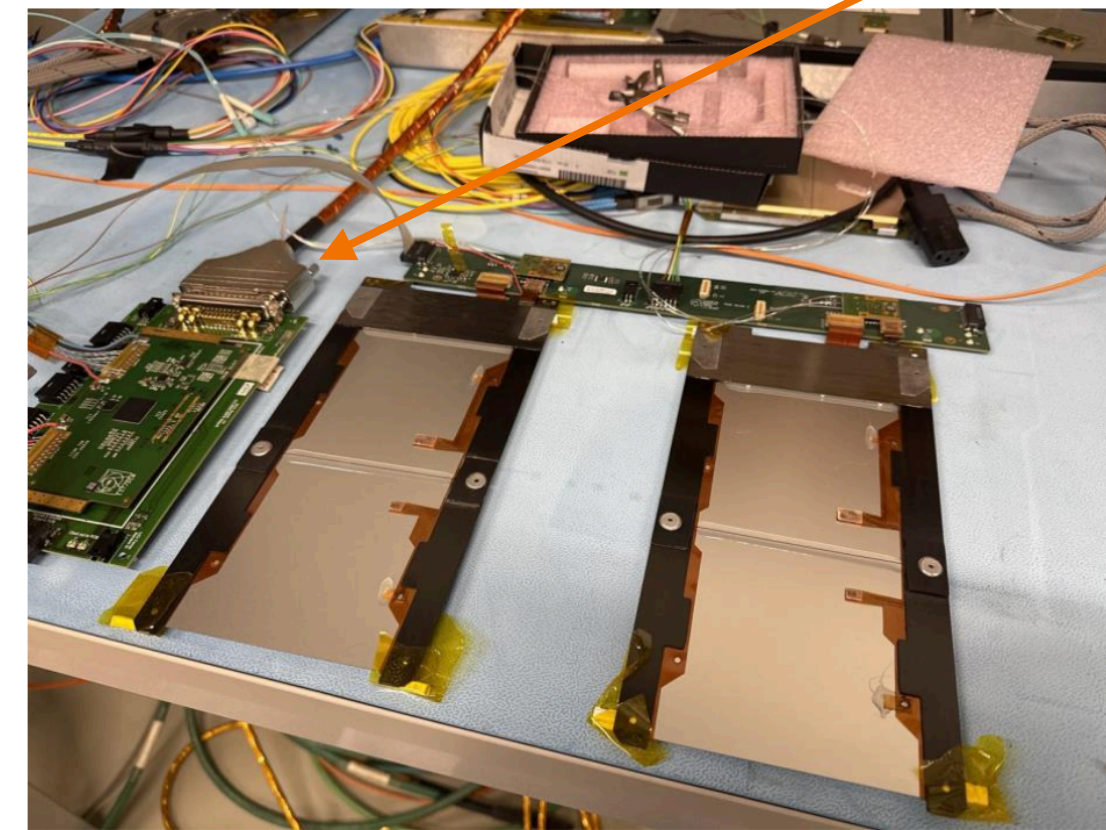
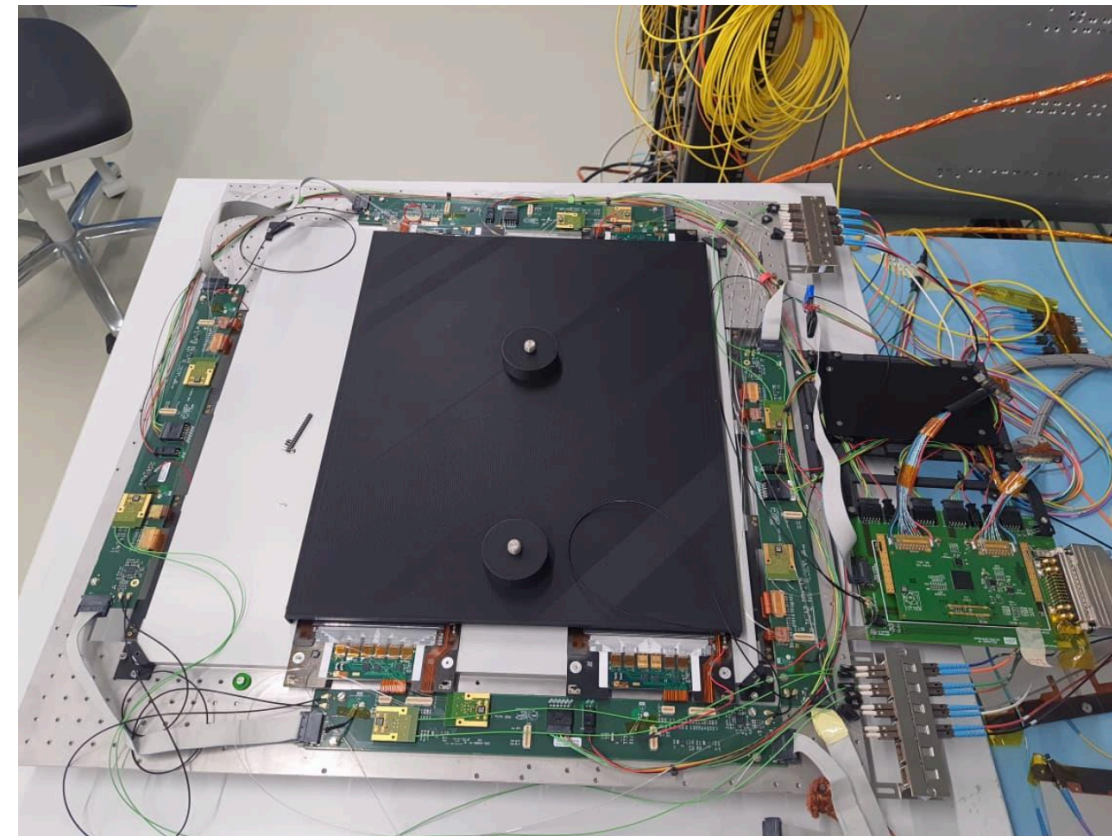

Magnetised calorimeter

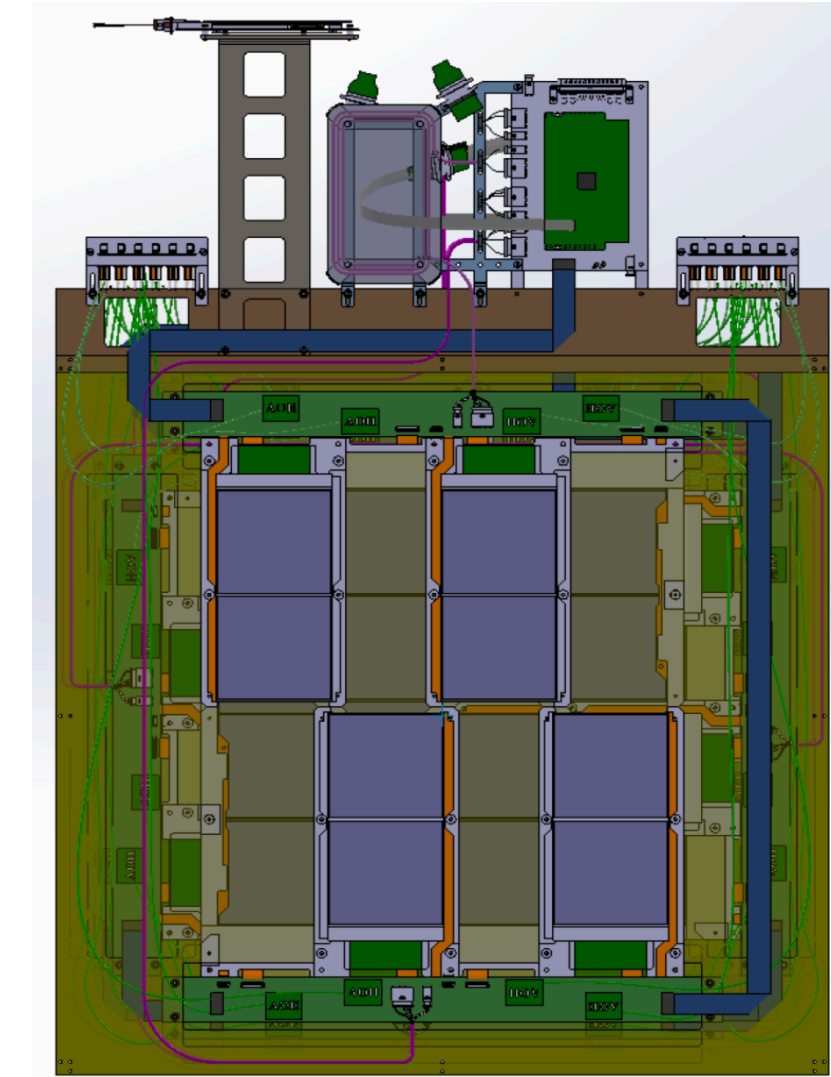
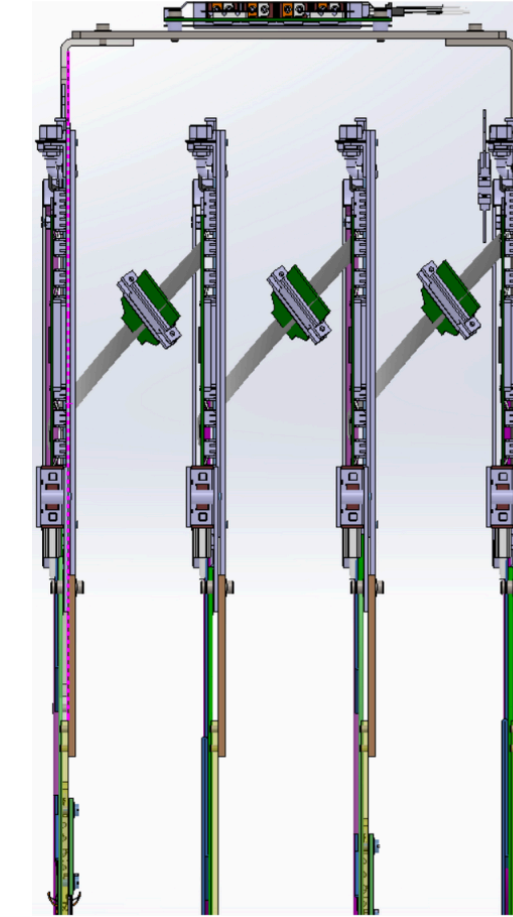
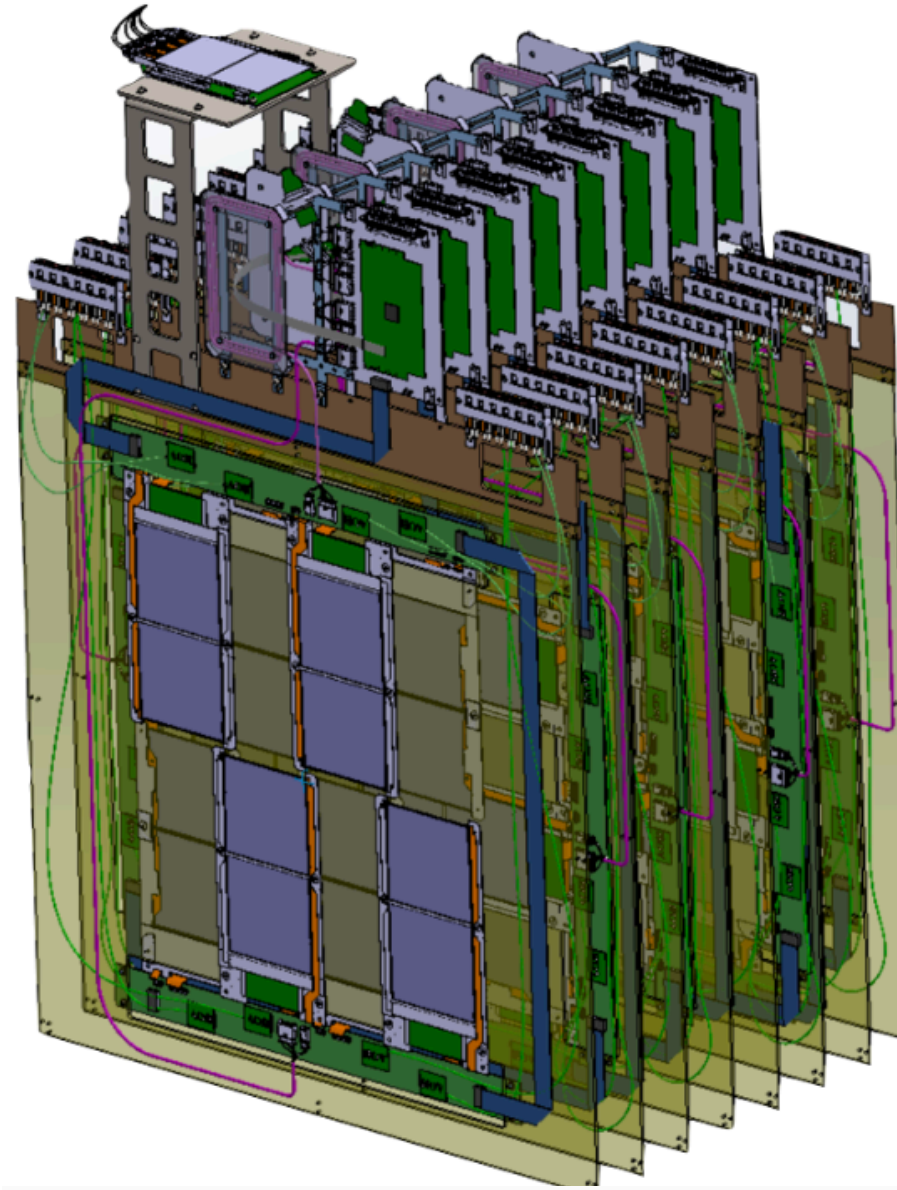
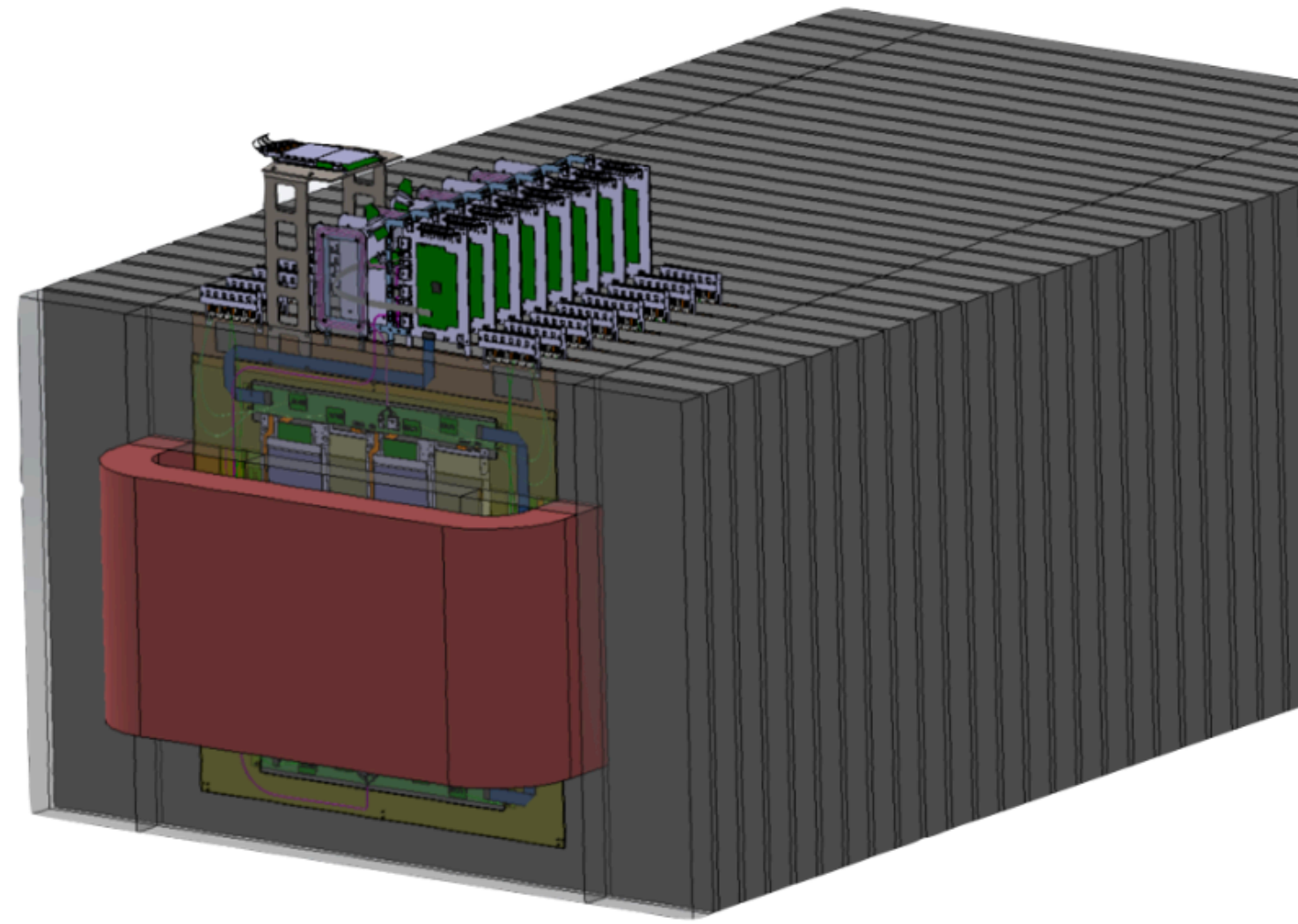

(RA)

detector design by LIP

→ towards integration and installation

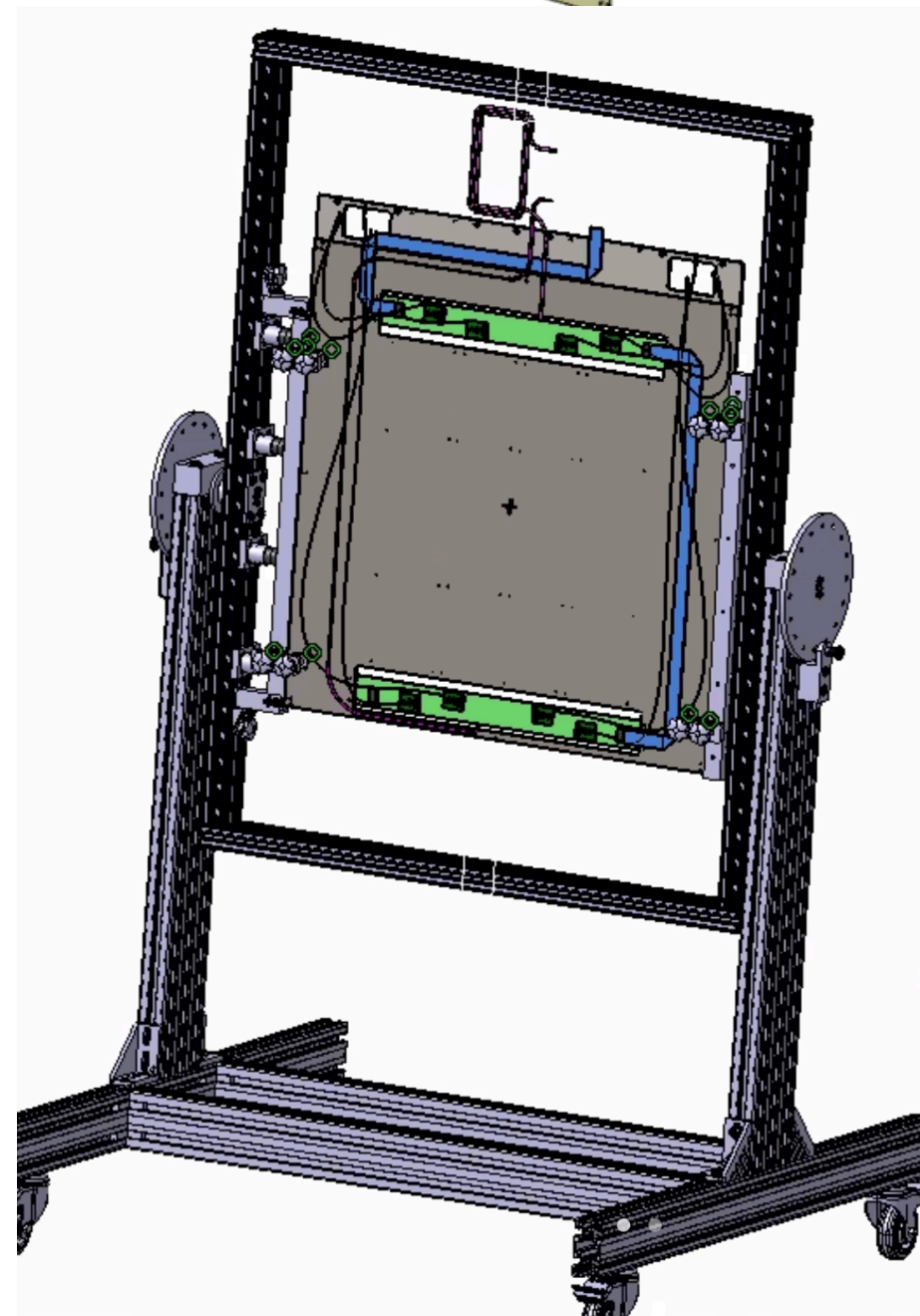
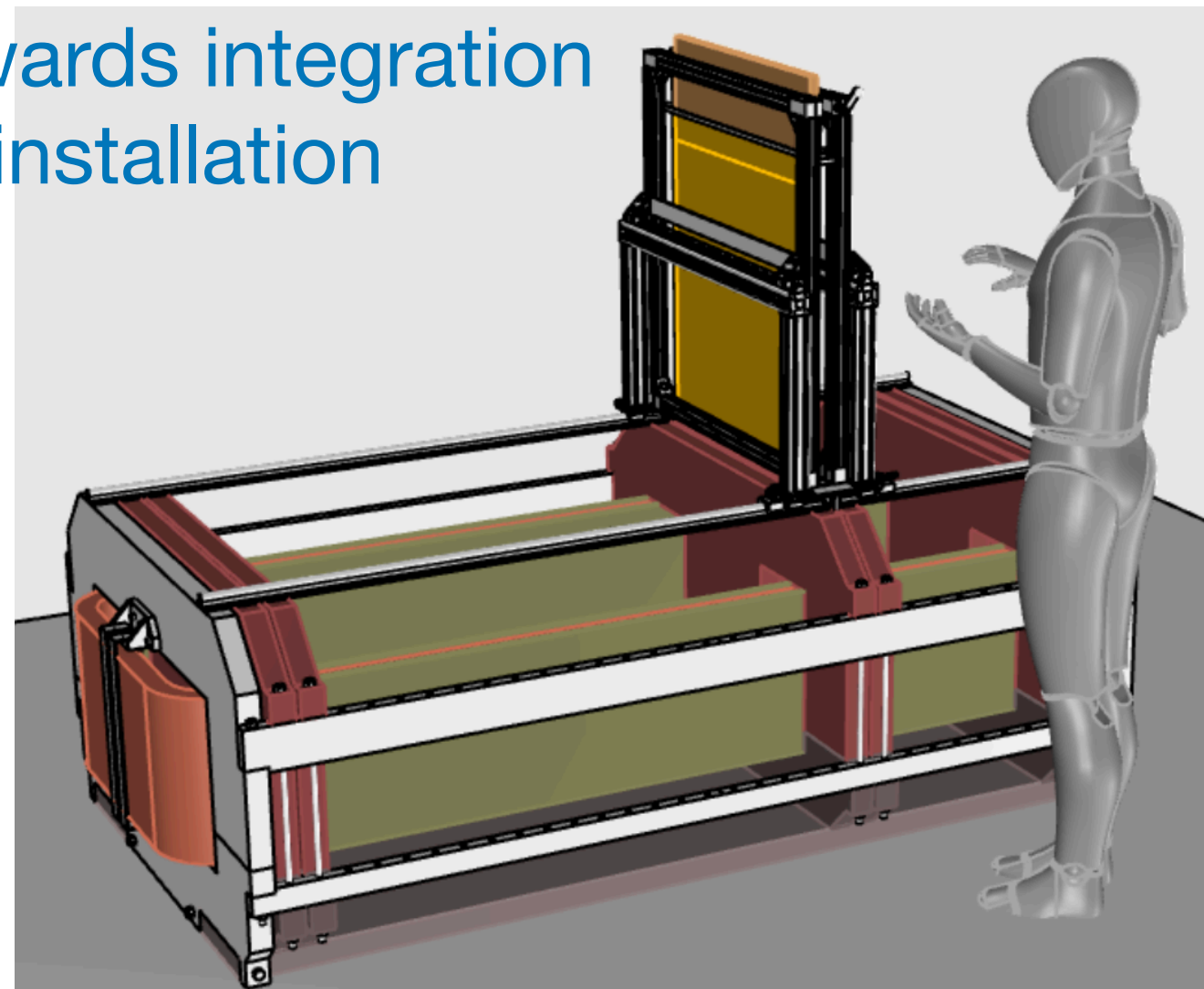

preparing mechanical prototype

productions by LIP (LL)

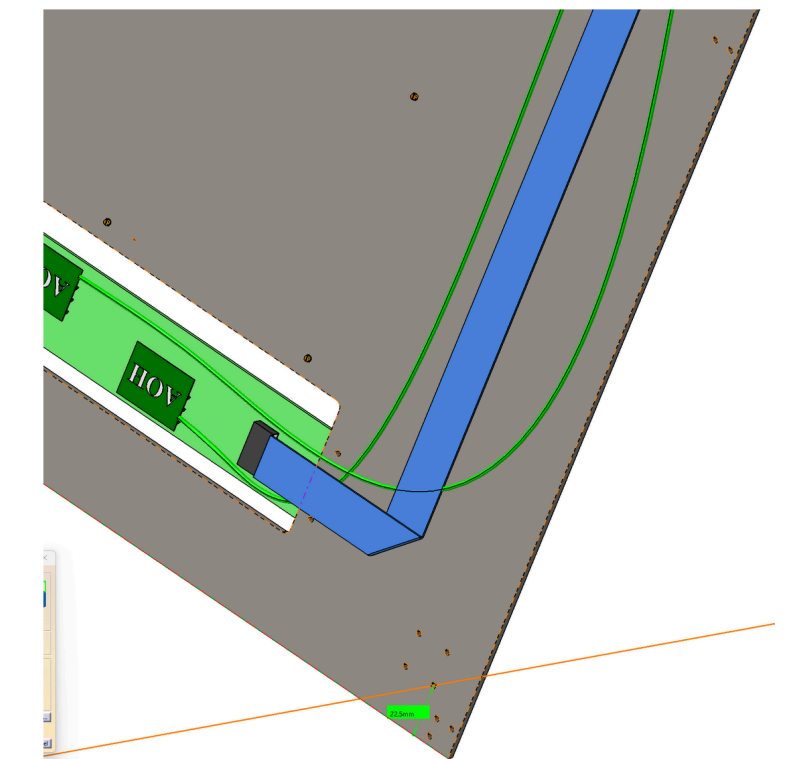
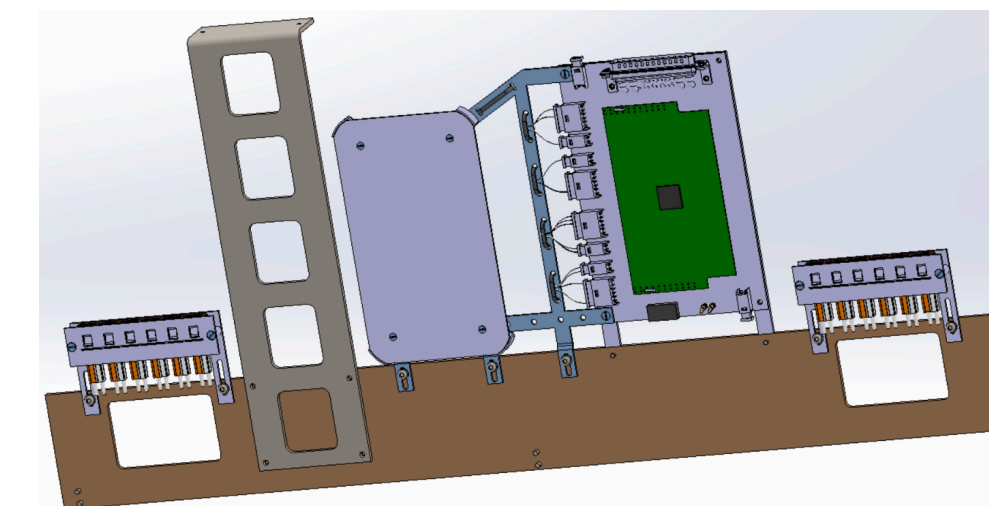

Trigger planes

- Required to generate triggers to **readout the silicon** microstrips
- And possibly also send triggers to ATLAS (for tagging the HF ν -parent)

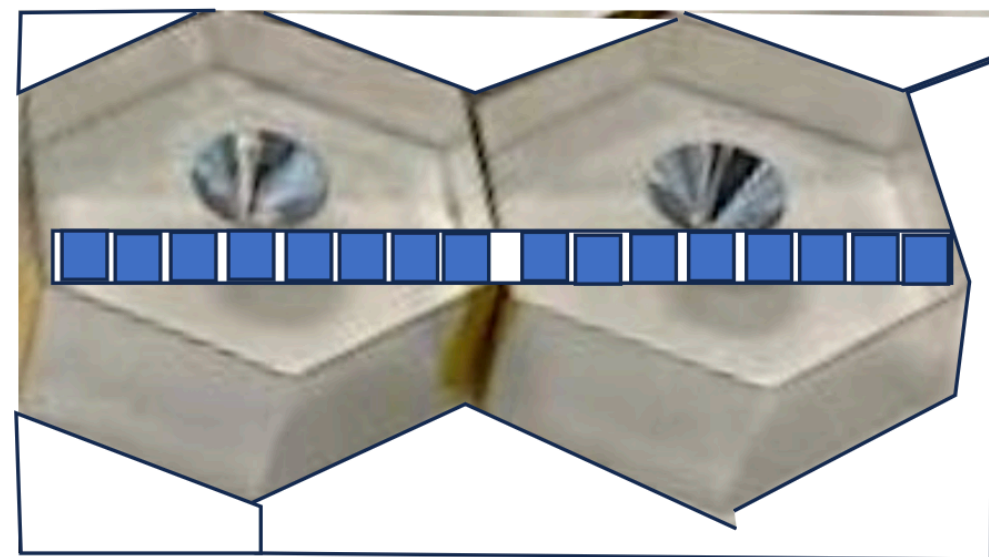

(TC)

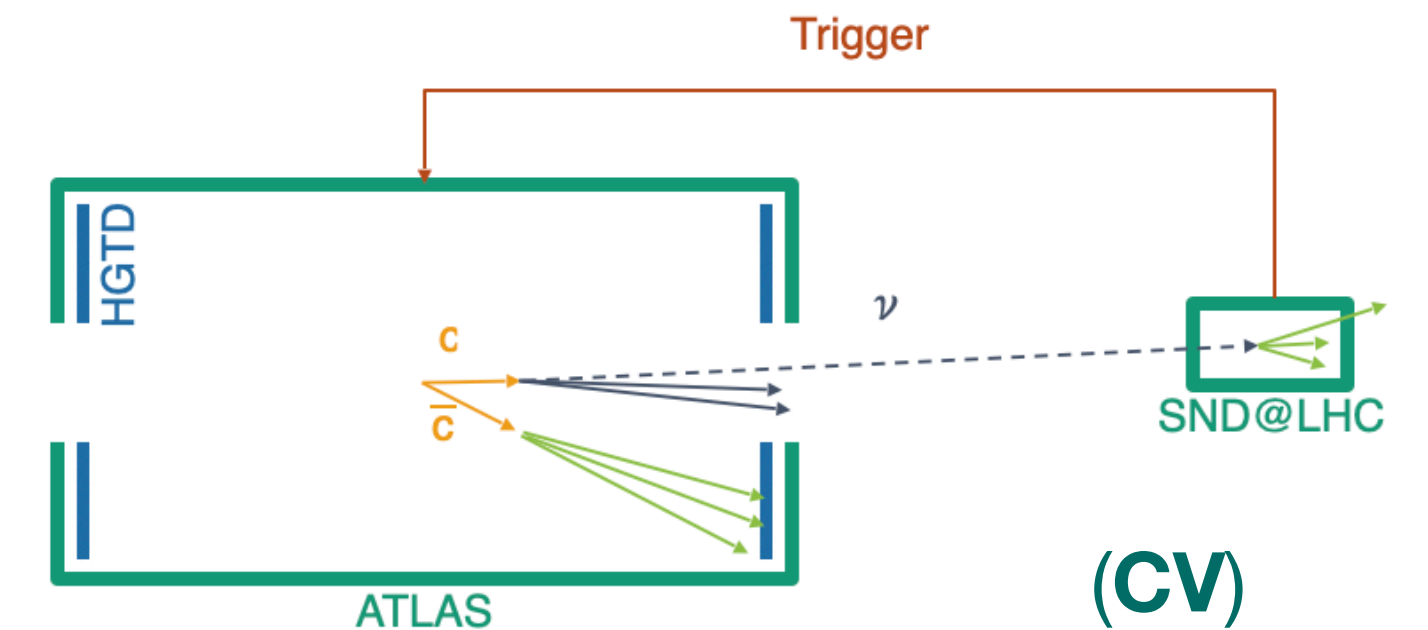

- Considering 4 trigger planes made of plastic **scintillator readout by SiPM**
 - optimising type/shape of scintillator cells
 - and number/placement of SiPM on cell
- We are exploring to use the **electronics chain** developed by **LIP for CMS**
 - based on the **ToFHIR** chip designed by **PETSYS**
 - demonstrated ability to achieve less than 50 ps timing resolution
 - at SND this would allow to send **trigger to ATLAS** DAQ for tagging the pp collision that generated the neutrino interacting at SND
- **LIP** team has already had **two test-beam** campaigns



S.W.O.T.

Strengths

- team formed of **consolidated researchers**
 - strongly integrated in the collaborations
 - leadership roles in **Detector and Physics**
 - close collaboration with **LIP infrastructures**
-
- Physics Coordination (CV)
 - Upgrade Coordination (TC)
 - Editorial Board (NL)
 - Decay Vessel Task Force (AB)

Opportunities

- SND@LHC collecting unique datasets, **extending LHC physics** reach
- **HL-LHC upgrade** offers exciting opportunities for LIP
- SND + SHiP facilitate long-term **synergies** — in **detector and physics**
- **Novel windows** in the exploration of Neutrinos *and* New Particles (FIPs)

Weaknesses/Threats

- responsibilities undertaken by the group demand **sustainable funding**: pay collaboration dues; detector construction & operations & upgrade R&D; support researcher's missions; award studentships

Funding

- last Fundo-CERN call was very favourably evaluated by FCT
 - but withdrawn due to issue in overall LIP's applications
 - agreement with LIP management supporting basic functioning
- applications have been also submitted to other FCT and European calls
 - this year: 2 exploratory projects (1 physics, 1 upgrade)
- hoping for Fundo CERN call soon

Backup



Trigger planes

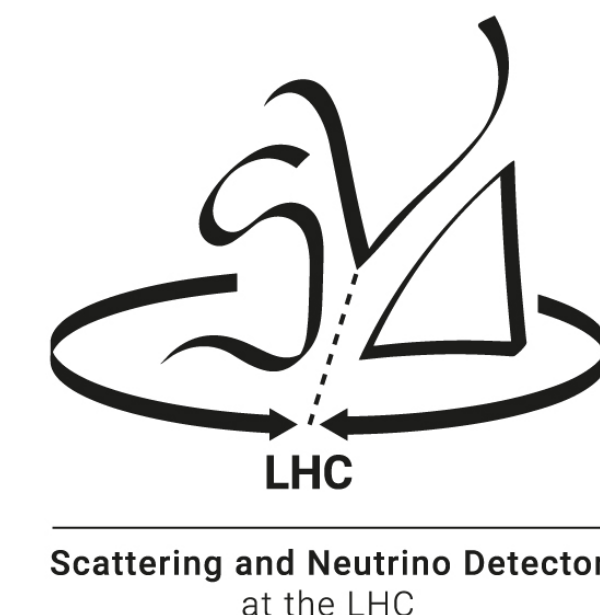

We will need to generate triggers signaling the neutrino interaction within $3.5 \mu\text{s}$ in order to readout the silicon microstrips.

We are exploring using the electronic chain developed by the LIP team of CMS based on the ToFHIR chip designed by PETSYS. Such chain has demonstrated the ability to achieve less than 50 ps timing resolution. Achieving similar timing resolutions in SND could allow us to send the trigger to the ATLAS acquisition which would allow tagging the proton-proton collision which generated the neutrino interacting in SND.

For our trigger planes we plan to use plastic Scintillators (EJ200 or similar) readout by SiPM. We are optimizing the shape of the scintillator cells and the number and placement of the SiPM on the cell. The LIP team has already had two test beam campaigns.

the test beam setup

- The 4 cells next to the two SiPM arrays (2x16) connected to the 'CMS' Tofhir Front End card and ready to be glued to the 4 Scintillator Cells
- With such setup we can study the resolution of the hexagonal geometry and validate with real data the effect of SiPMs placement on the surface of the Scintillator Cell
- We also are testing different type of plastic scintillator (e.g. EJ200, EJ204)



Some initial analysis of Test beam

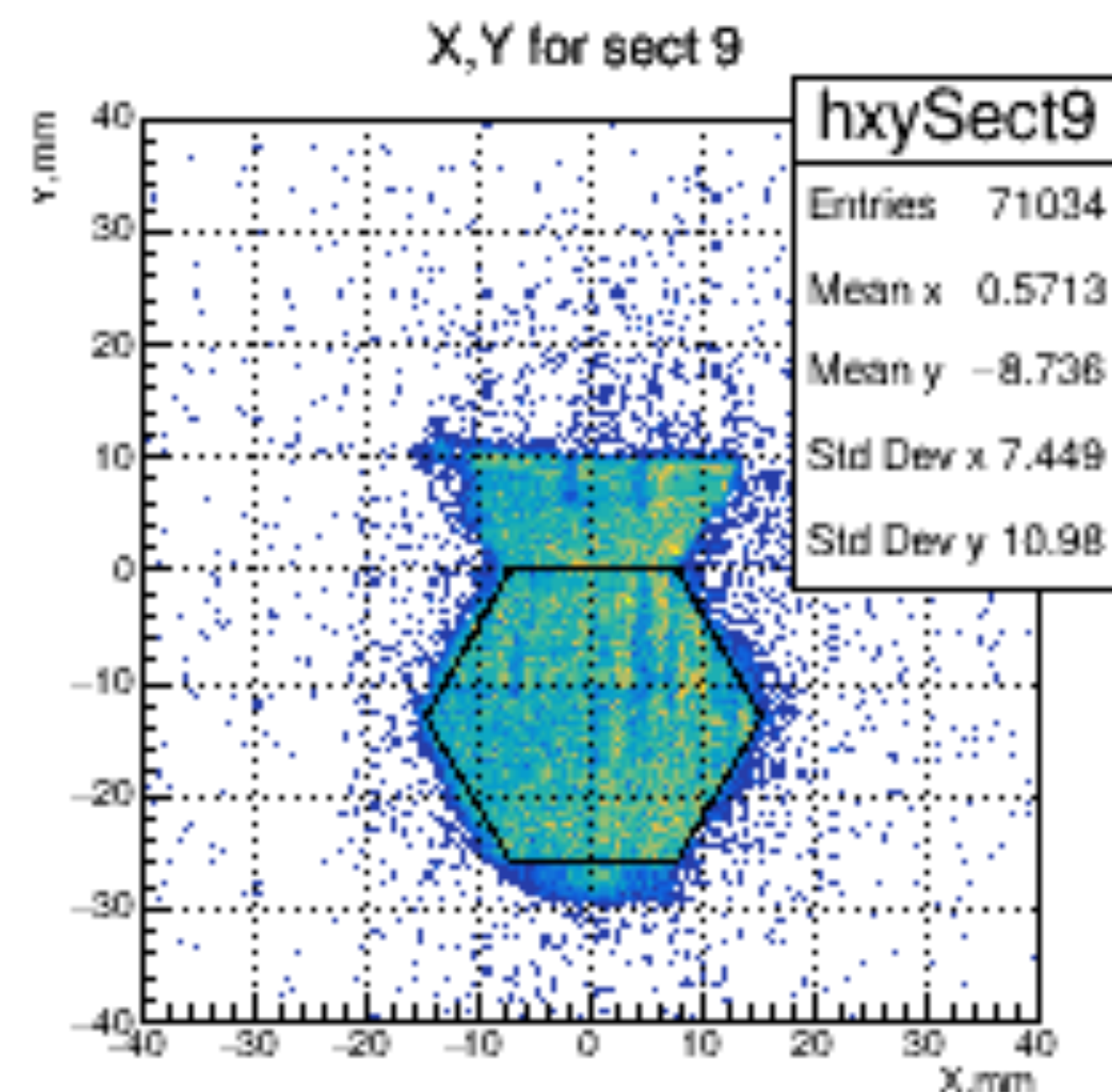
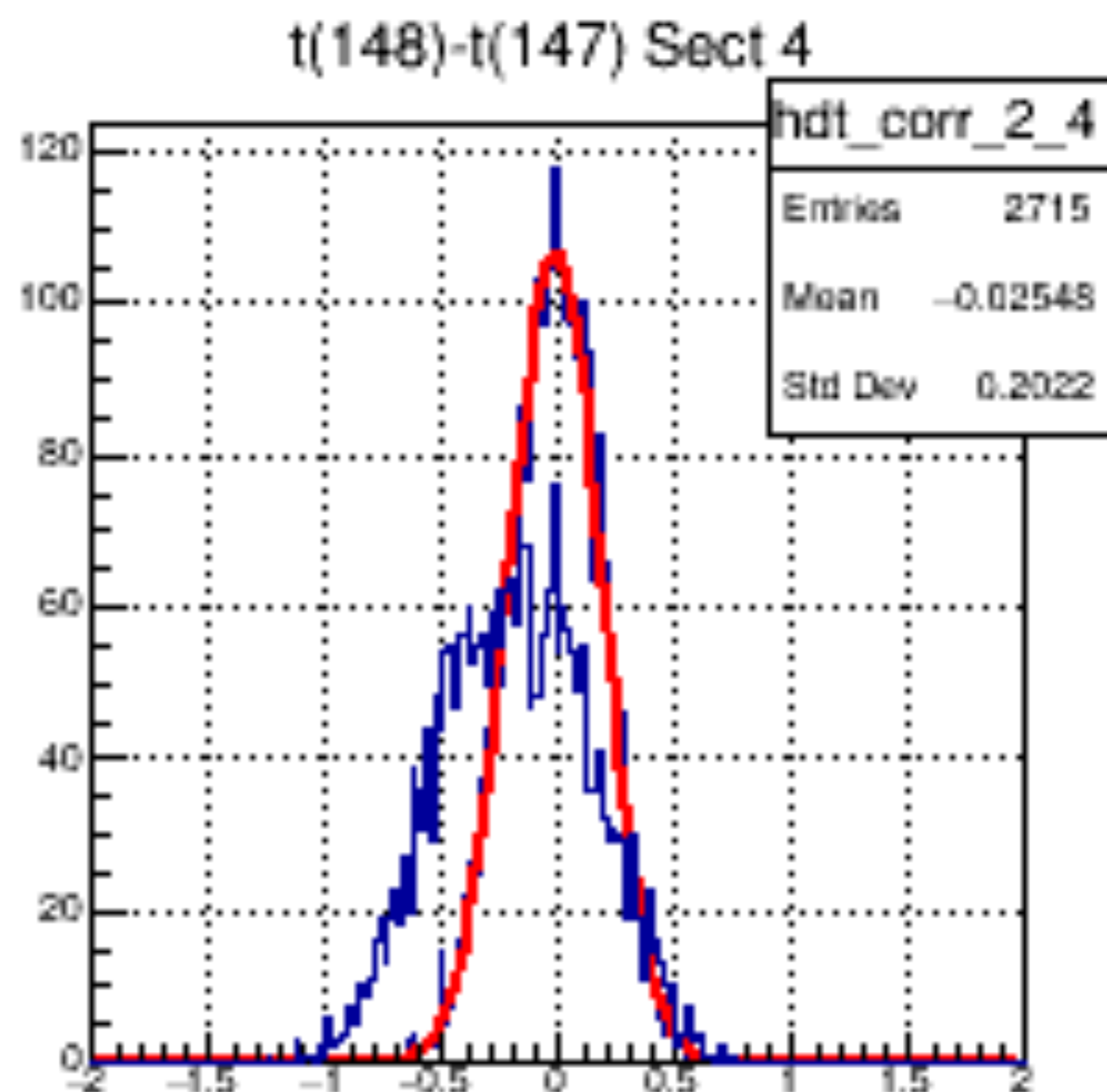
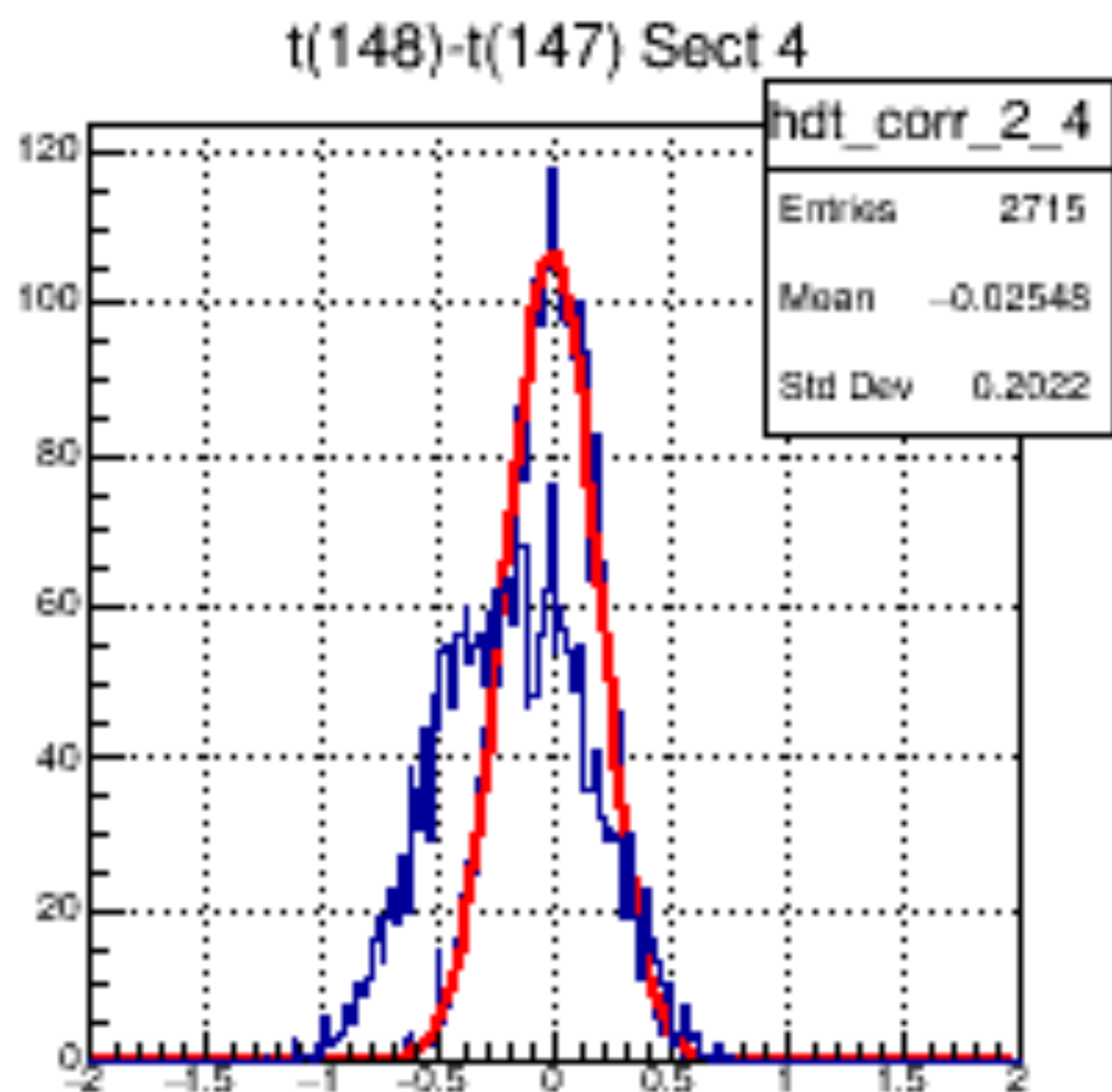

Δt for pairs of SIPMs

Impact point of muons on cells (tracking done by Delay wire chambers0