

The Standard Model Higgs and beyond

Michele Gallinaro

LIP Lisbon

April 20, 2026

- ✓ The Higgs boson and beyond
- ✓ Charged Higgs
- ✓ BSM Higgs: light pseudo-scalar, non-SM Higgs decay
- ✓ Higgs boson and Dark Matter



$H \rightarrow ZZ \rightarrow 4e, 4\mu, 2e2\mu$

- Signal: 4 isolated leptons from same vertex
 - Small background
 - Fully reconstructed, mass resolution $\sim 1\%$

The golden channel

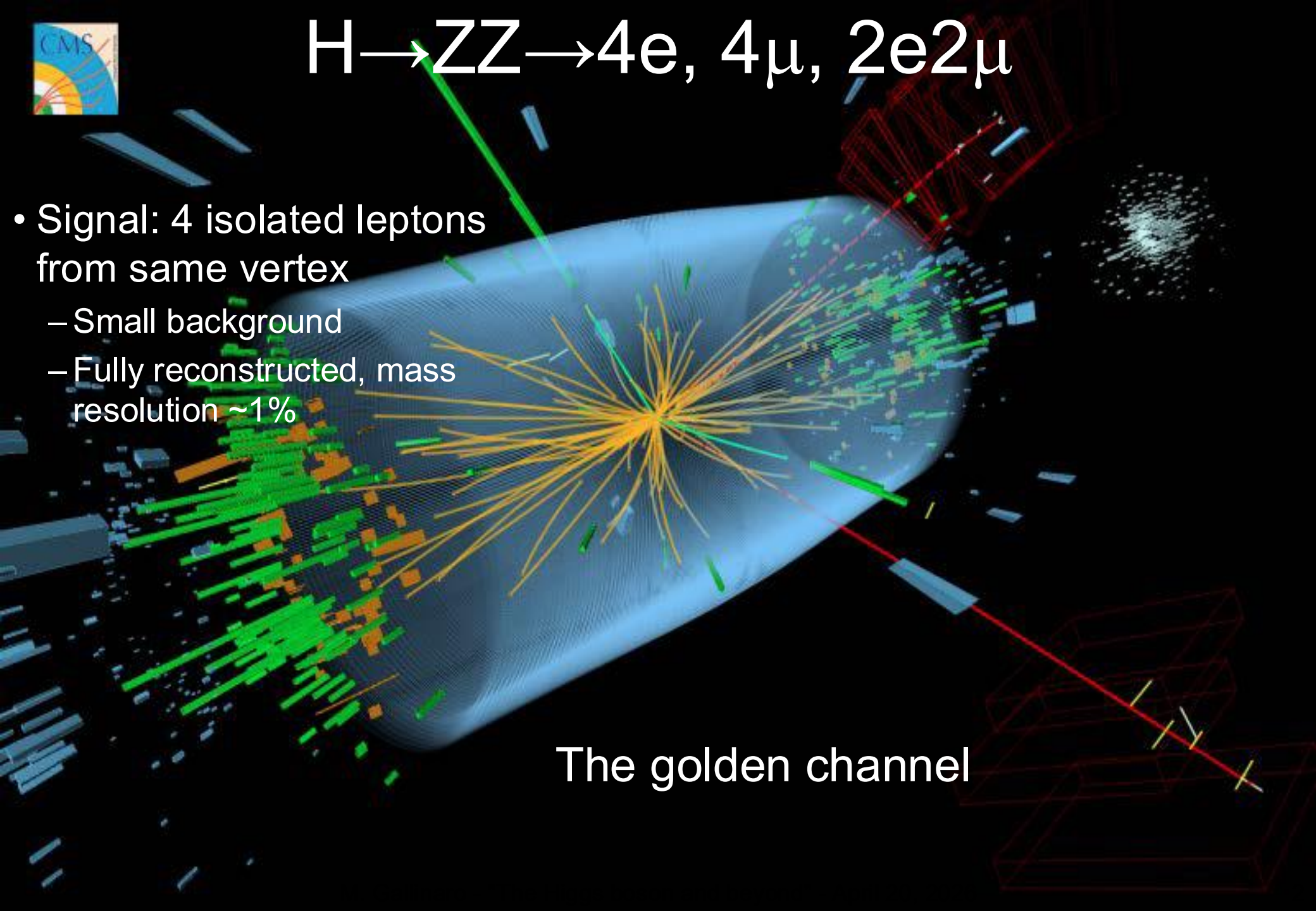

July 4th, 2012: A Higgs boson

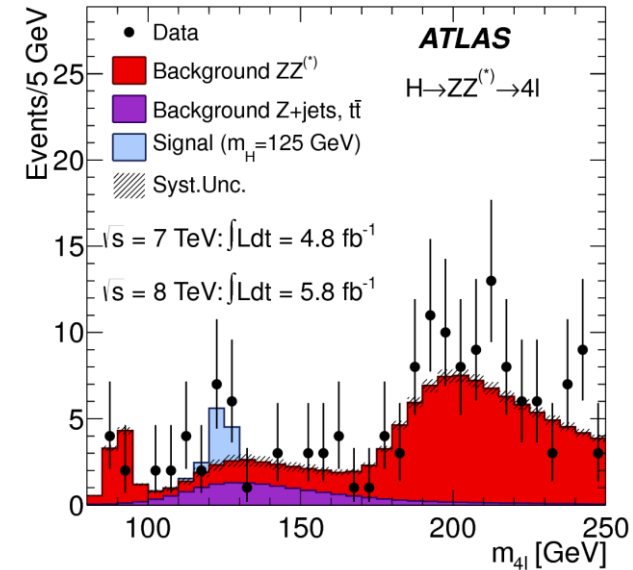
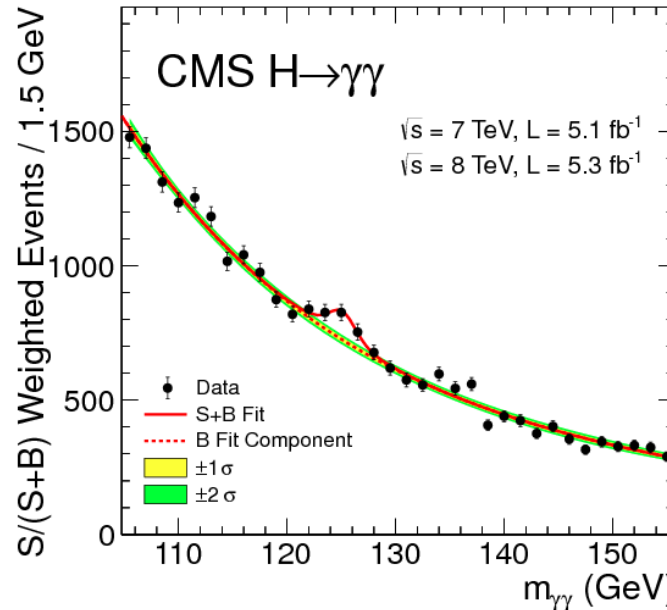
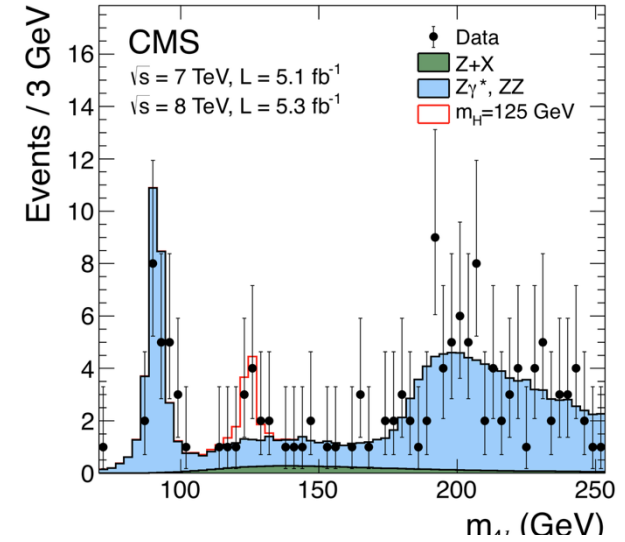
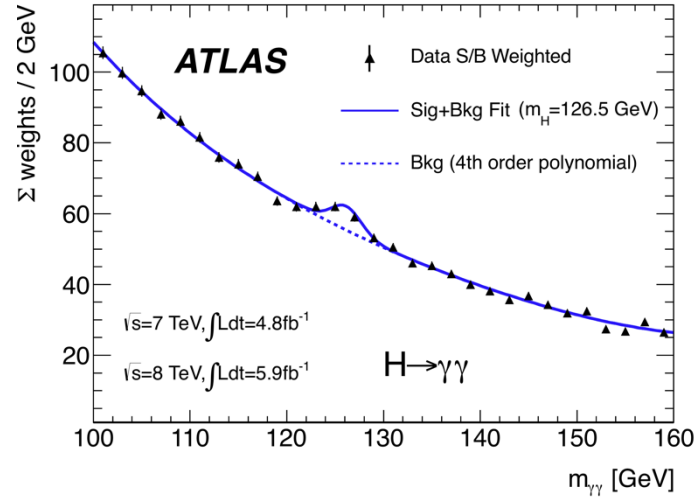
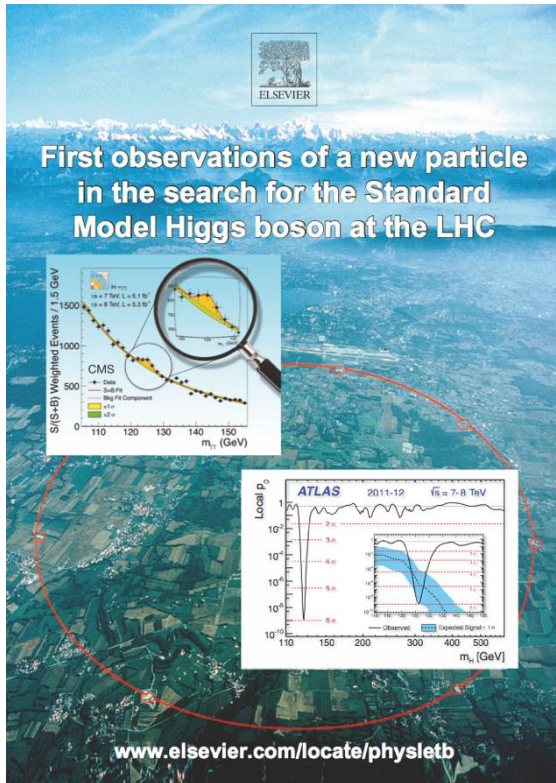

Higgs and ZZ

EPJC 81(2021)200, arXiv:2103.04956

- Study of SM ZZ production, and Higgs decay to ZZ
 - ~98% of Run2 data
- SM cross section measured with 3% precision

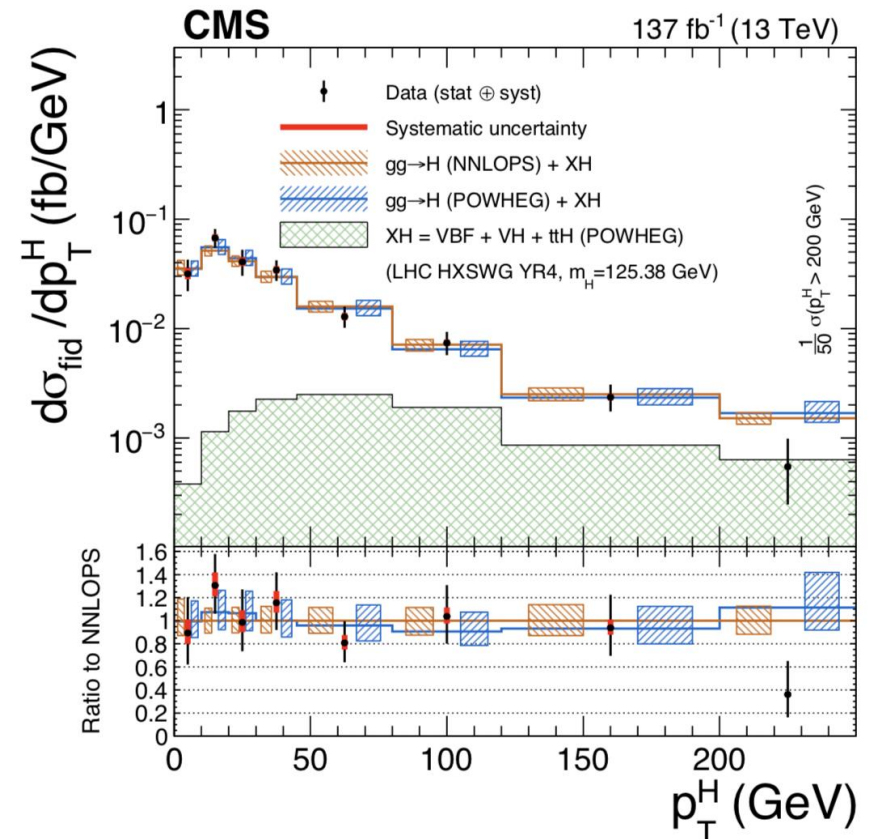
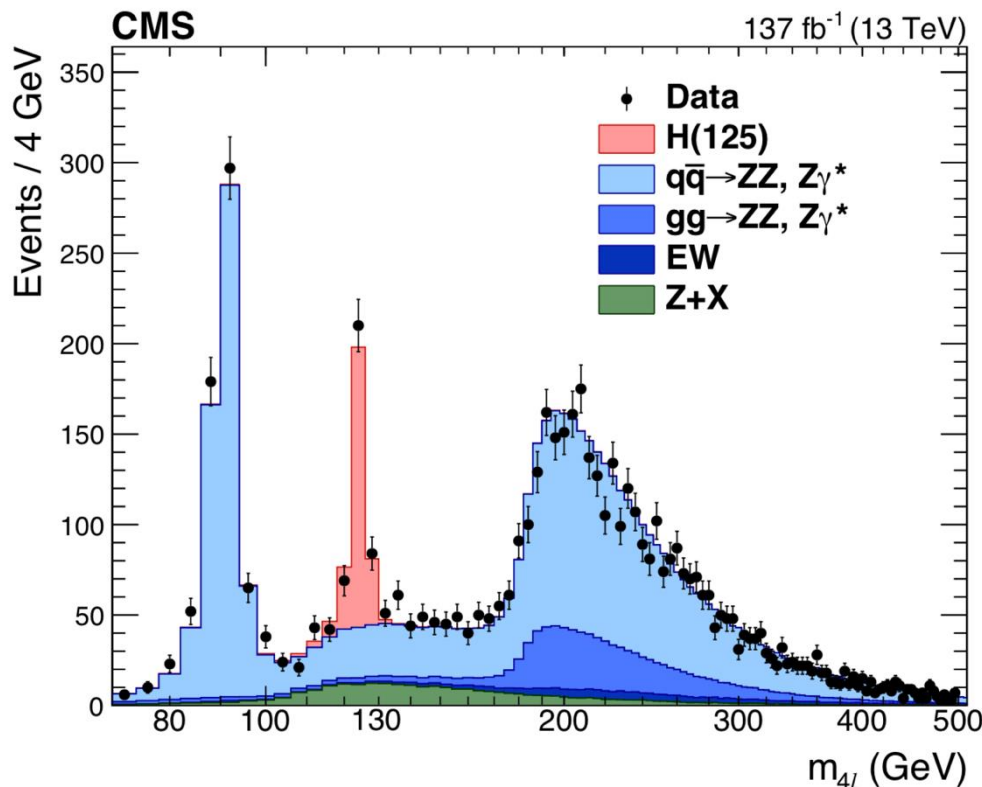

Low mass-resolution channels

JHEP 03(2929)034, HIG-19-010, PRL 121(2018)121801

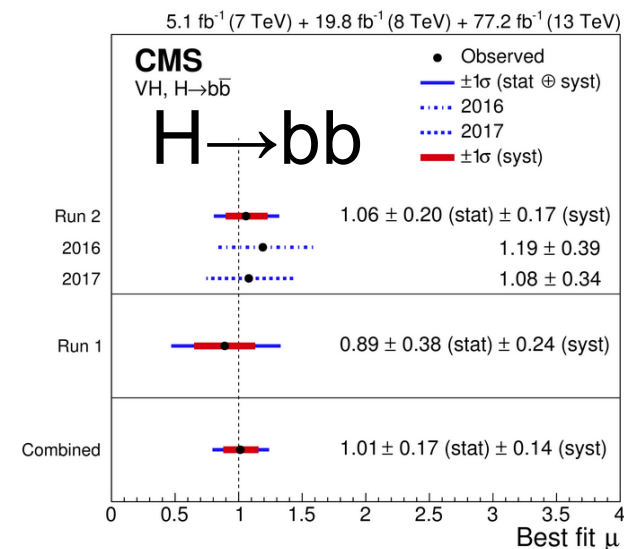
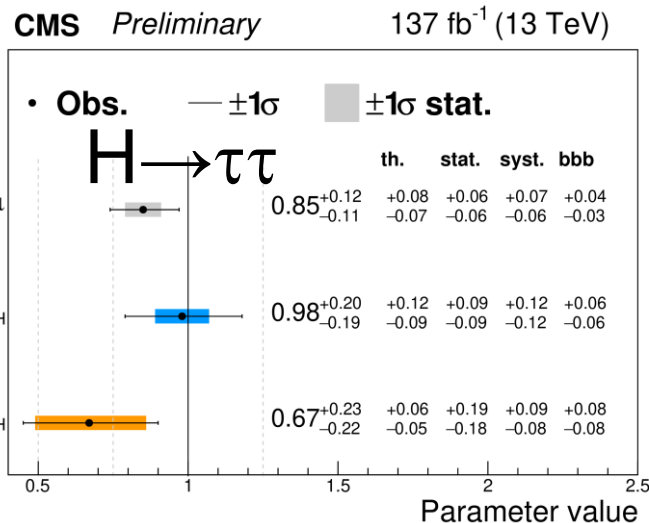
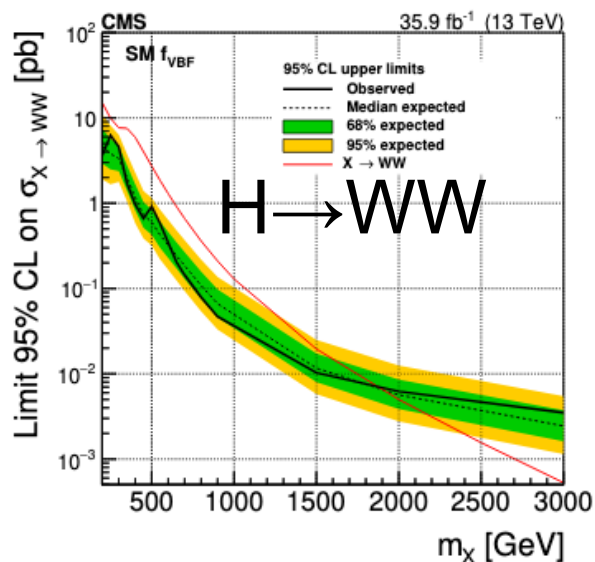
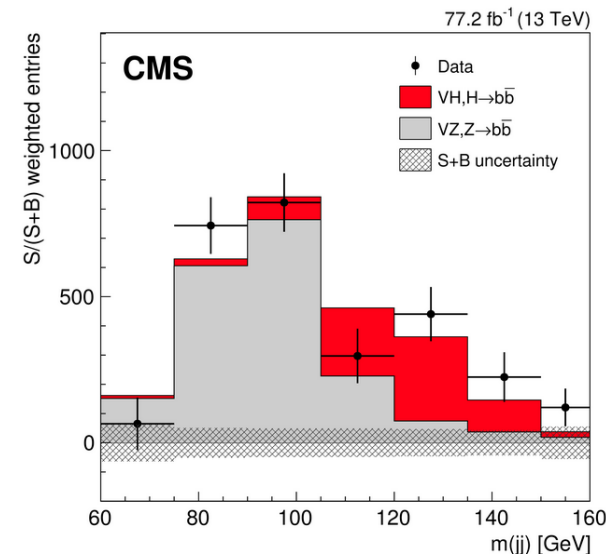
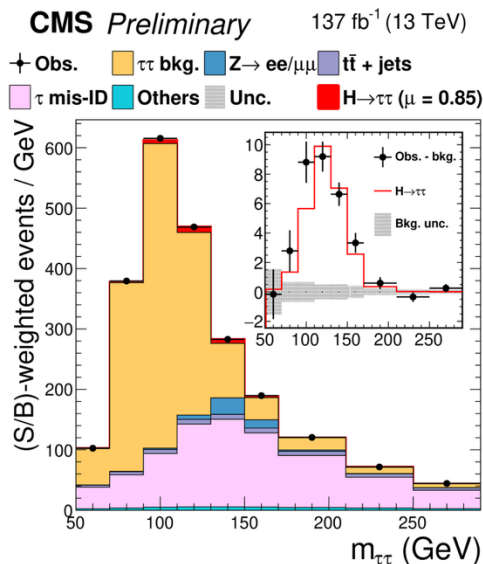
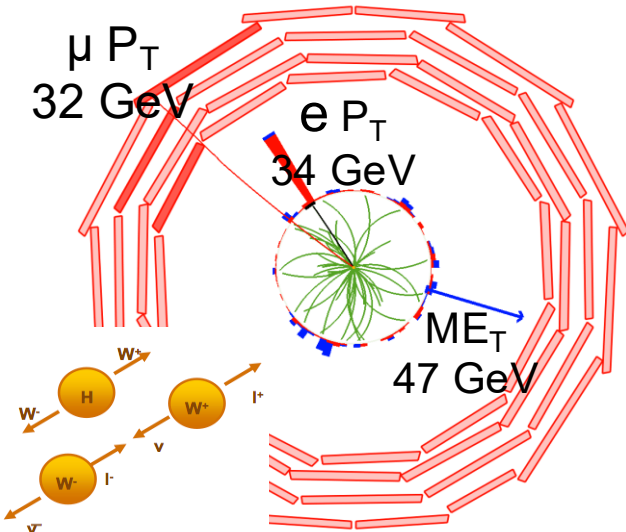

Rare decays: $H \rightarrow \mu\mu, c\bar{c}$

JHEP 01(2021)148, arXiv:2205.0550, arXiv:2211.14181

Study couplings to 2nd generation

- $H \rightarrow \mu\mu$
 - Most sensitive category is VBF channel
 - Obs.(exp.): 3.0σ (2.5σ)
- $H \rightarrow c\bar{c}$
 - Low cross section, need c-tagging
 - Use resolved (2jets) and merged (1jet),
 - Use ML and **large jet** substructure for tagging and classification
 - Validate using VZ production:

$$\mu_{VZ(cc)} = 1.01^{+0.23}_{-0.21} \quad (5.7\sigma)$$

- Set limits

$$\sigma(VH) \mathcal{B}(H \rightarrow c\bar{c}) < 0.94 \text{ pb}$$

$$1.1 < |\kappa_c| < 5.5 \quad (|\kappa_c| < 3.4)$$

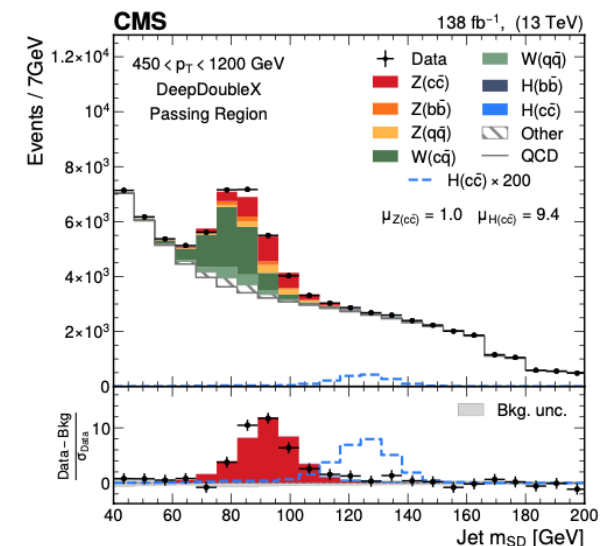
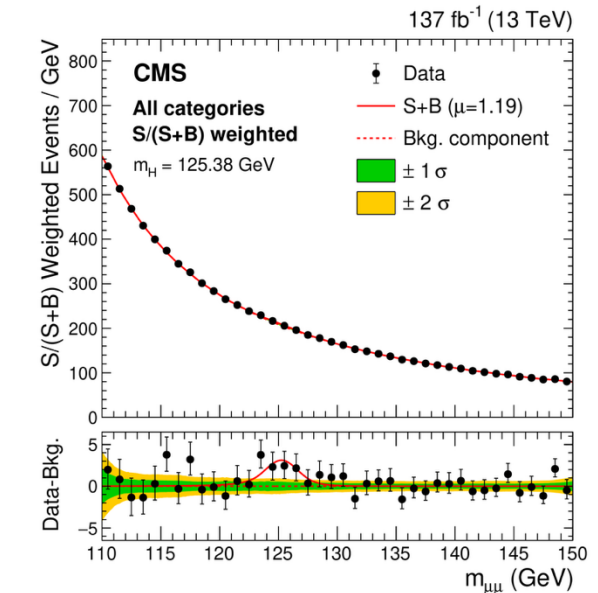

Search for SM $H \rightarrow \mu\mu$

JHEP 01(2021)148

- Small rate: $\mathcal{B}(H \rightarrow \mu^+ \mu^-) = 2.18 \times 10^{-4}$
- Search based on BDT discriminant
 - Event categories based on BDT score
- Weighted sum of individual fits to each category
- Signal strength: $\mu = 1.19^{+0.40}_{-0.39} \text{ (stat)}^{+0.15}_{-0.14} \text{ (syst)}$

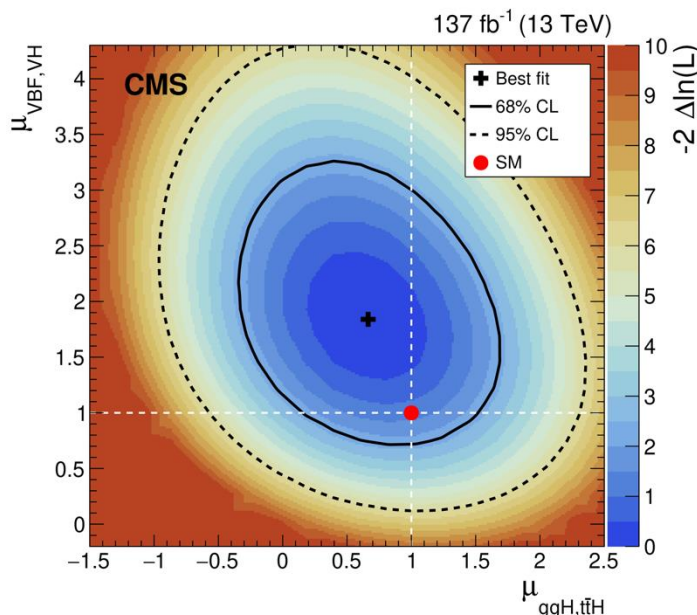
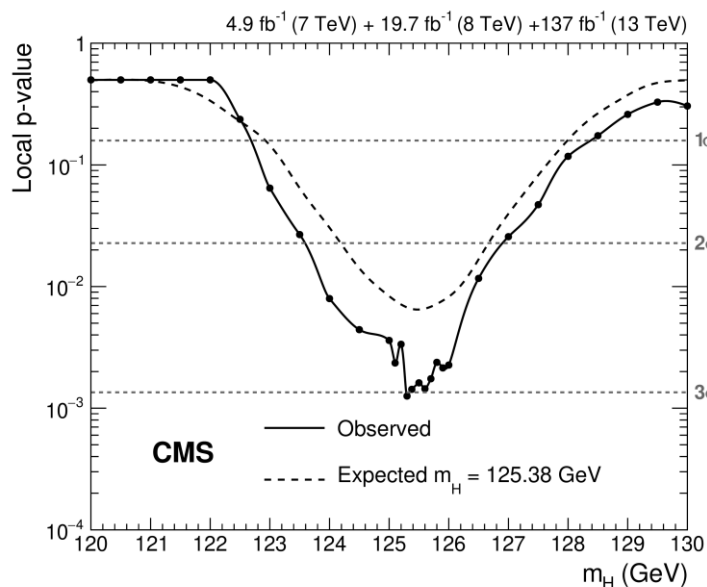
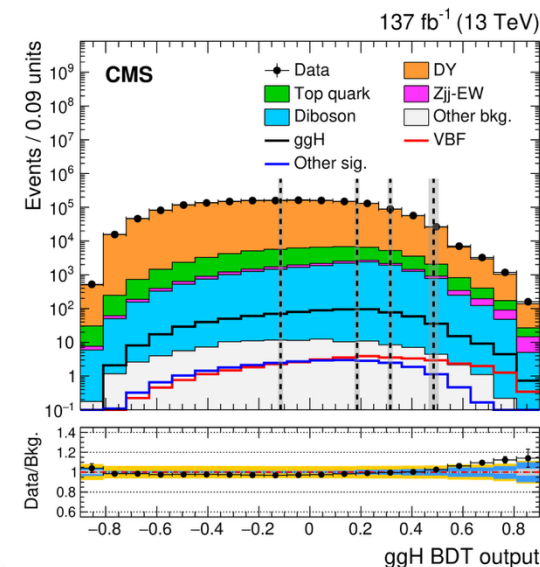

Search for rare decays

PLB 797(2019)134811, arXiv:2103.10322, EPJC 79(2019)94, PLB 793(2019)520, CMS-HIG-20-008

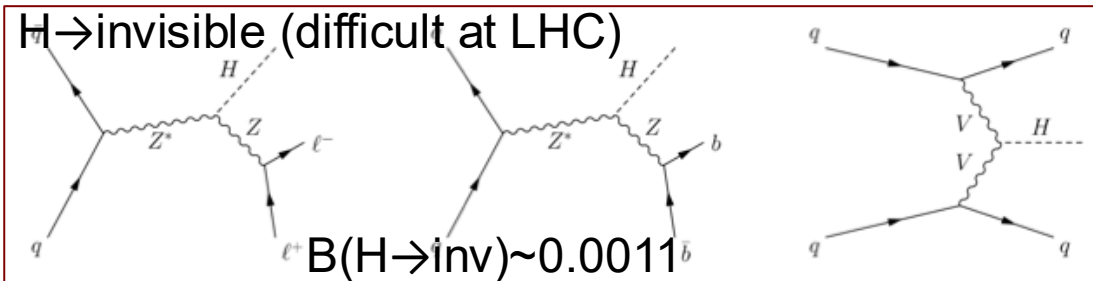
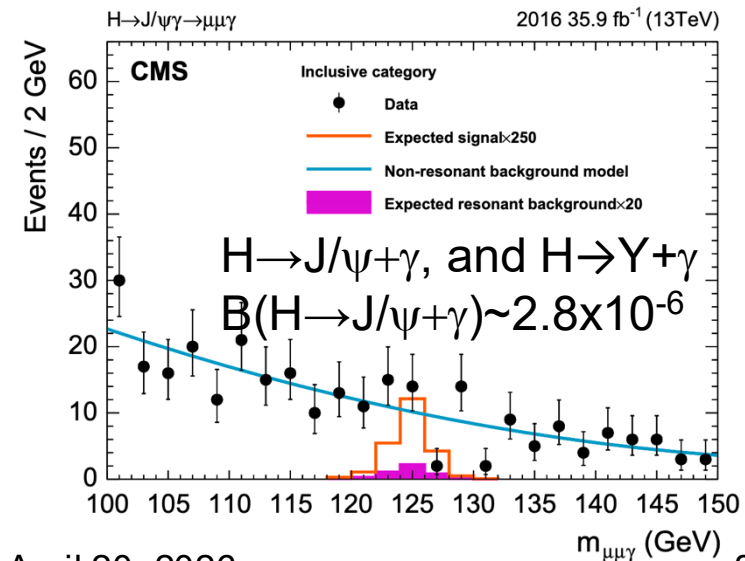
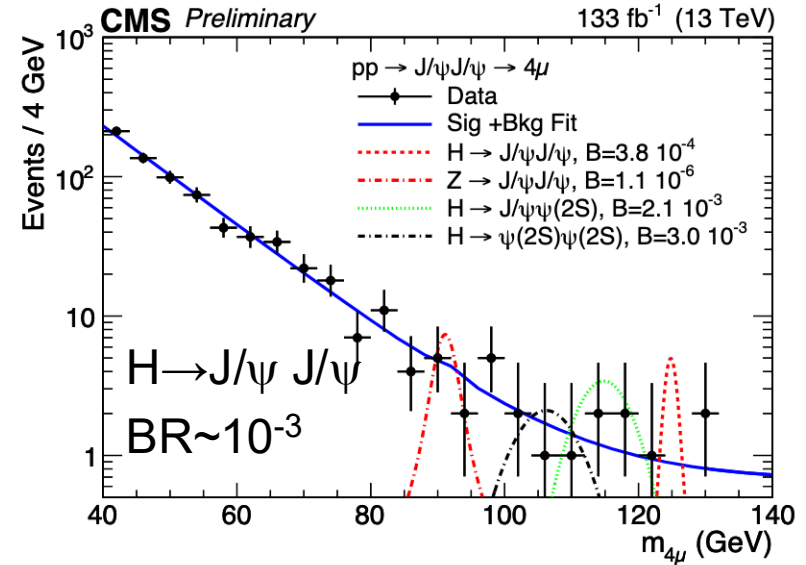
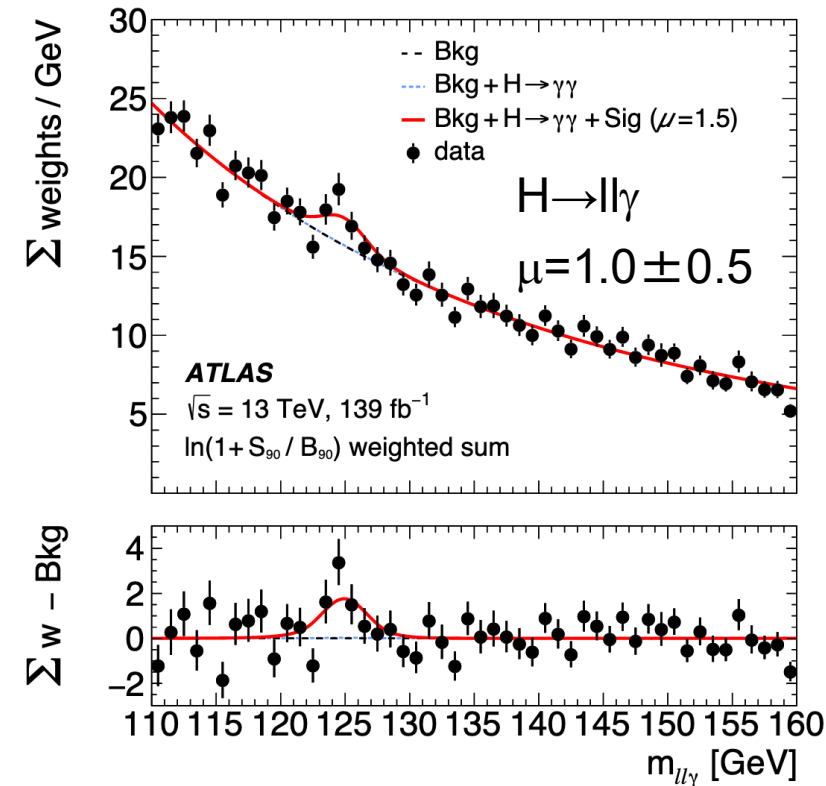

Higgs and the SM

- SM is a successful theory
- Nothing prevents the SM to survive up to the Planck scale. However, it is **unnatural**.
- Virtual particles in quantum loops contribute to the Higgs mechanism
 - contributions grow with Λ (upper scale validity of the SM)
 - Higgs mass depends quadratically on Λ : $m^2 = m_0^2 + g^2\Lambda^2$
- Miraculous cancellations are needed to keep $m_H < 1\text{TeV}$
- Is there a symmetry that protects the Higgs mass from receiving large corrections?

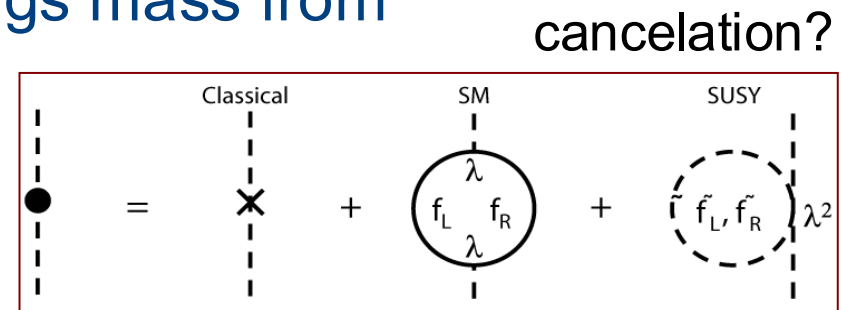

Higgs and the SM (cont.)

- SUSY postulates a new symmetry between fermions and bosons
 - Loops of particles and their SUSY partners have the ability to cancel the quadratic divergences in the Higgs field self-couplings, solving the naturalness problem
 - SUSY foresees unification of couplings at large energy scales $\sim 10^{15}$ GeV
 - Provides DM candidates (LSP)
- It suggests many options, but the LHC may not be able to find it
- # of experimental scenarios is large

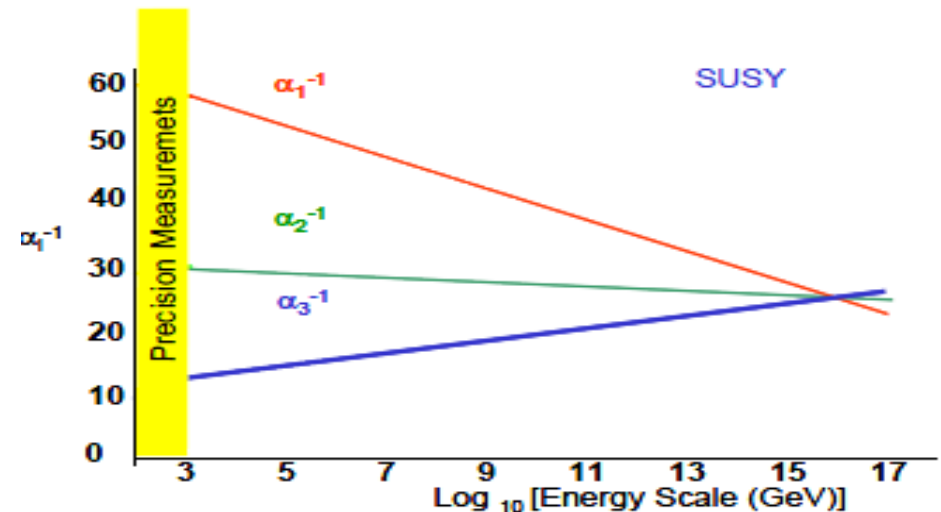

Higgs and BSM

ATLAS-CONF-2015-044, CMS-HIG-15-002

- Is there BSM physics **hidden** in the “Higgs sector”?

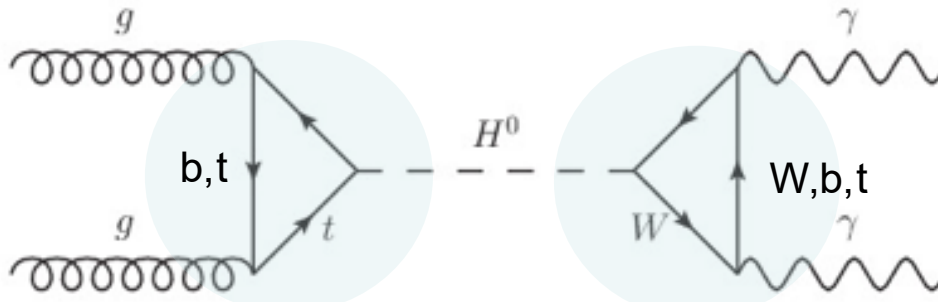

$$(\sigma \cdot \text{BR})(gg \rightarrow H \rightarrow \gamma\gamma) = \sigma_{\text{SM}}(gg \rightarrow H) \cdot \text{BR}_{\text{SM}}(H \rightarrow \gamma\gamma) \cdot \frac{\kappa_g^2 \cdot \kappa_\gamma^2}{\kappa_H^2}$$

Experimental approach

- Measure H(125) properties
- Search for additional Higgs bosons
- Search for BSM in signatures with Higgs bosons
- Search for BSM Higgs decays

Strategy: parametrize deviations wrt SM in production and decay
 ⇒ loops are sensitive to BSM physics

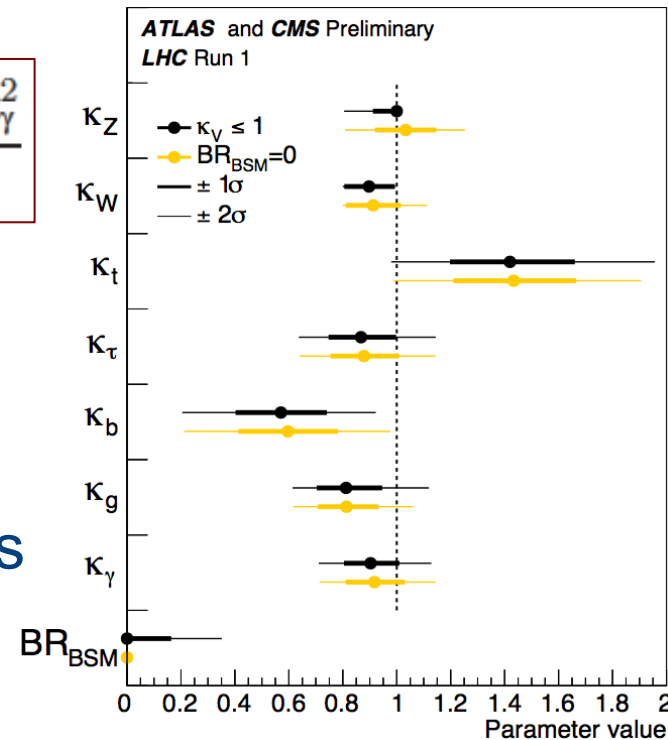

Looking for new particles

JHEP08(2016)045

- Constrain BR_{BSM} in a scenario with free parameters

$$\Gamma_{tot} = \Gamma_{WW} + \Gamma_{ZZ} + \Gamma_{bb} + \dots + \Gamma_{BSM}$$

- Likelihood scan vs BR_{BSM}
- Assuming couplings bound by SM expectations ($k_v < 1$)
- $0 \leq BR_{BSM} \leq 0.34$ at 95%CL

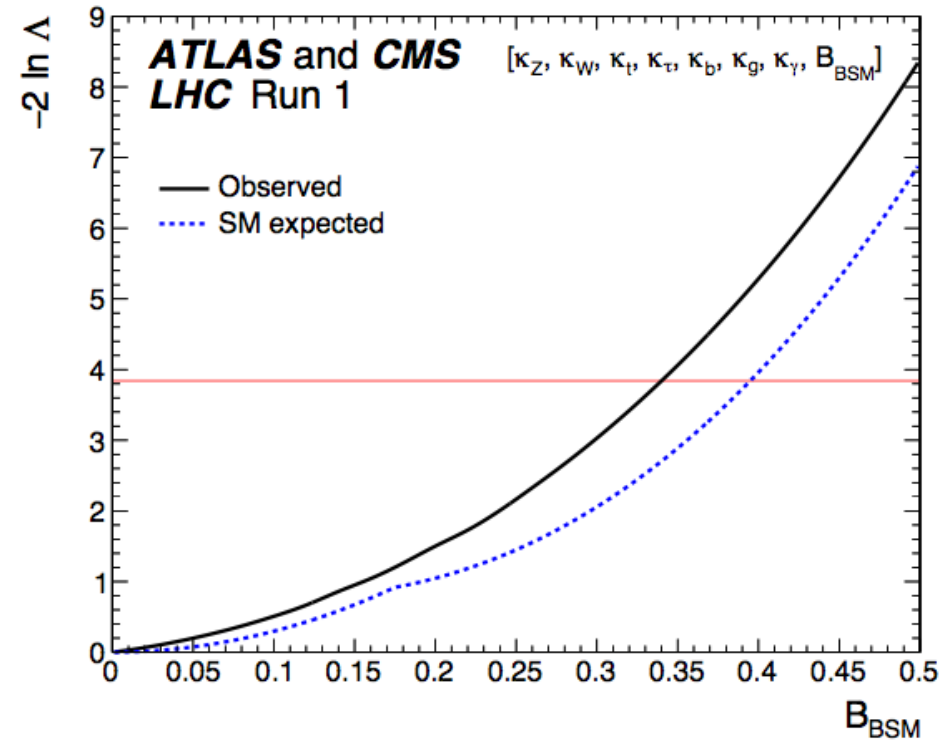

Constraining Higgs width

PLB 736(2014)64

- couplings and width sensitive probes to BSM
- indirectly constrained in coupling fits
- **off-peak to on-peak ratio proportional to Γ_H**
- constrain Higgs boson width by using off-shell production/decay
- measure ratio of $\sigma^{\text{off-peak}}$ to $\sigma^{\text{on-peak}}$

$$\sigma_{gg \rightarrow H \rightarrow ZZ}^{\text{on-peak}} \propto \frac{g_{ggH}^2 g_{HZZ}^2}{\Gamma_H}, \quad \sigma_{gg \rightarrow H \rightarrow ZZ}^{\text{off-peak}} \propto g_{ggH}^2 g_{HZZ}^2$$

F. Caola, K. Melnikov PRD88(2013)054024
 J. Campbell et al. arXiv:1311.3589

– g_{ggH} and g_{HZZ} : couplings to gluons and bosons

- measurement of Γ_H

obs.(exp.) @95%CL:

$$\Gamma_H < 5.4(8.0) \Gamma_H^{\text{SM}}$$

$$\Gamma_H < 22(33) \text{MeV}$$

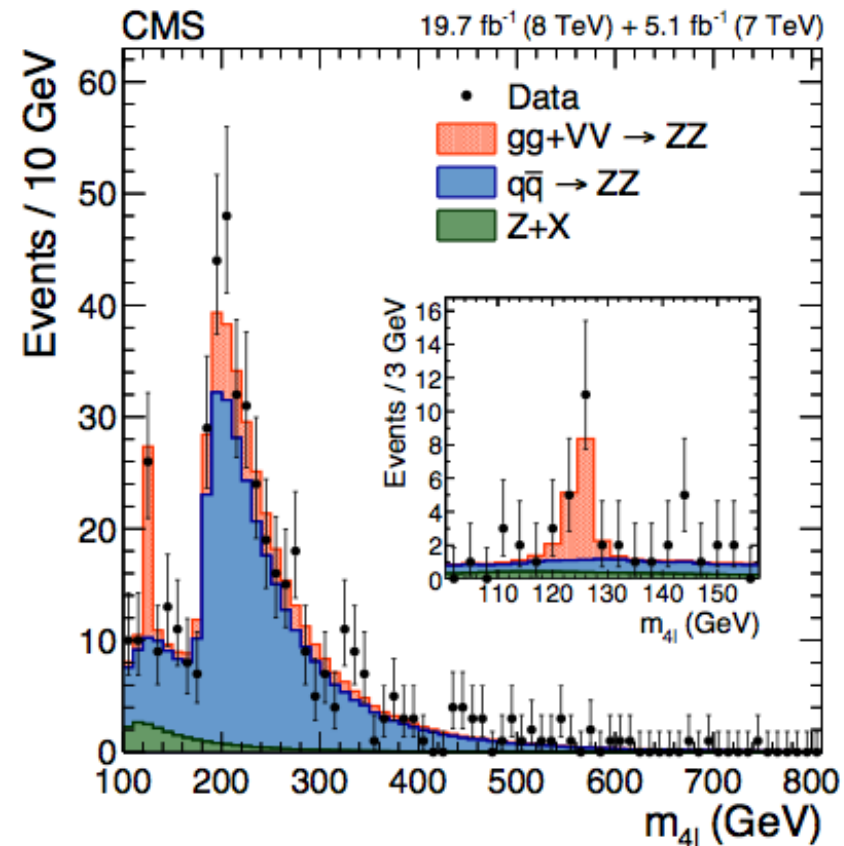

Higgs mass and width (cont.)

arXiv:2202.06923, arXiv:2409.13663

- Couplings and width sensitive probes to BSM
 - Total width of 4.1 MeV too small to measure directly
- Measure width by using off-shell production/decay: $H(ZZ)$
- Off-peak to on-peak ratio proportional to Γ_H

$$\frac{\sigma_{\text{off-shell}}^{\nu\nu \rightarrow H \rightarrow 4\ell}}{\sigma_{\text{on-shell}}^{\nu\nu \rightarrow H \rightarrow 4\ell}} \propto \Gamma_H$$

$$\Gamma_H = 3.0^{+2.0}_{-1.5} \text{ MeV}$$

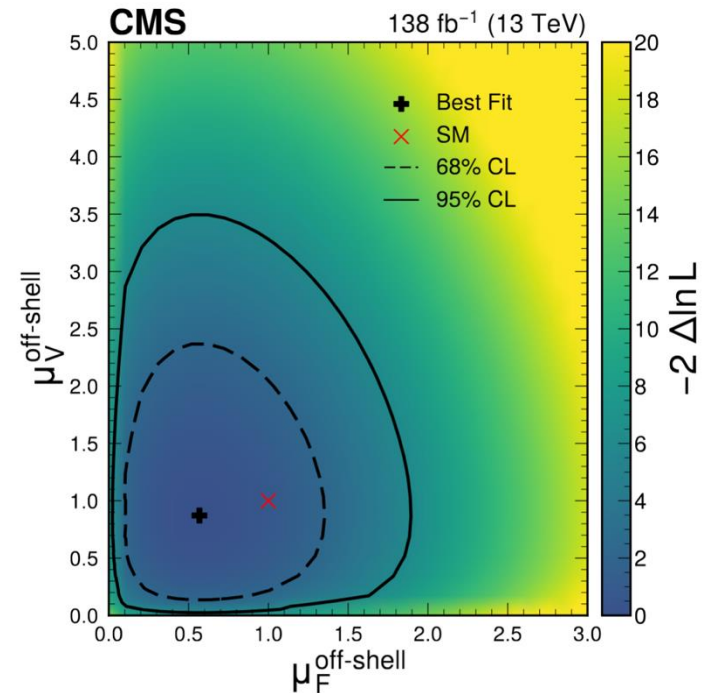
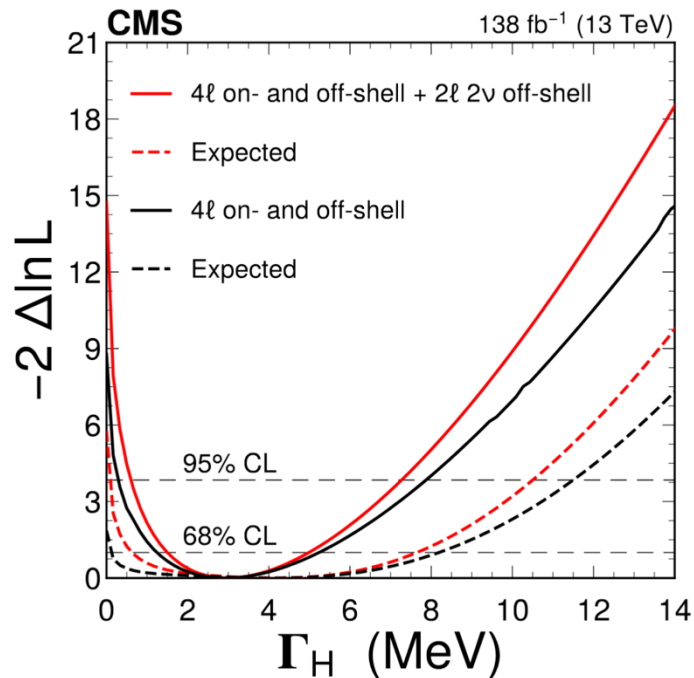

Couplings

Nature 607(2022)60

BSM physics in the loop

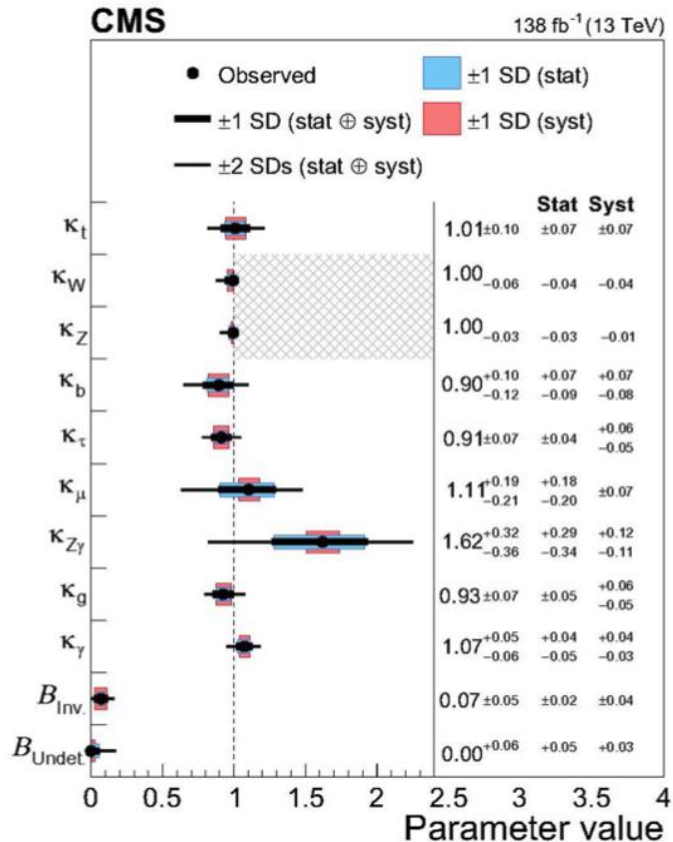

Vector and fermion couplings

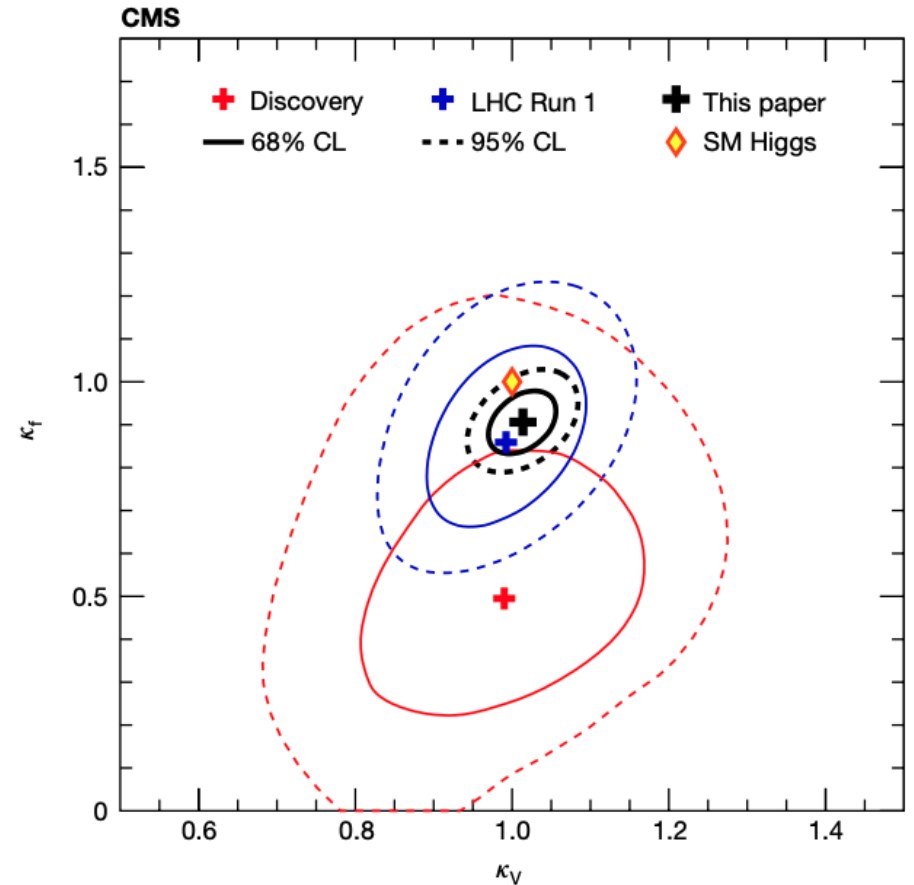

$BR_{inv} < 0.18$ (0.10) at 95% C.L. (assuming $\kappa_V \leq 1$)

BR_{undet} includes non-standard decays, visible or invisible

⇒ Results in agreement with SM ($\kappa_V = \kappa_F = 1$)

Ultimate precision

CMS-HIG-21-018

- Combination of production and decay modes
- Simultaneous measurement of $O(100)$ cross sections

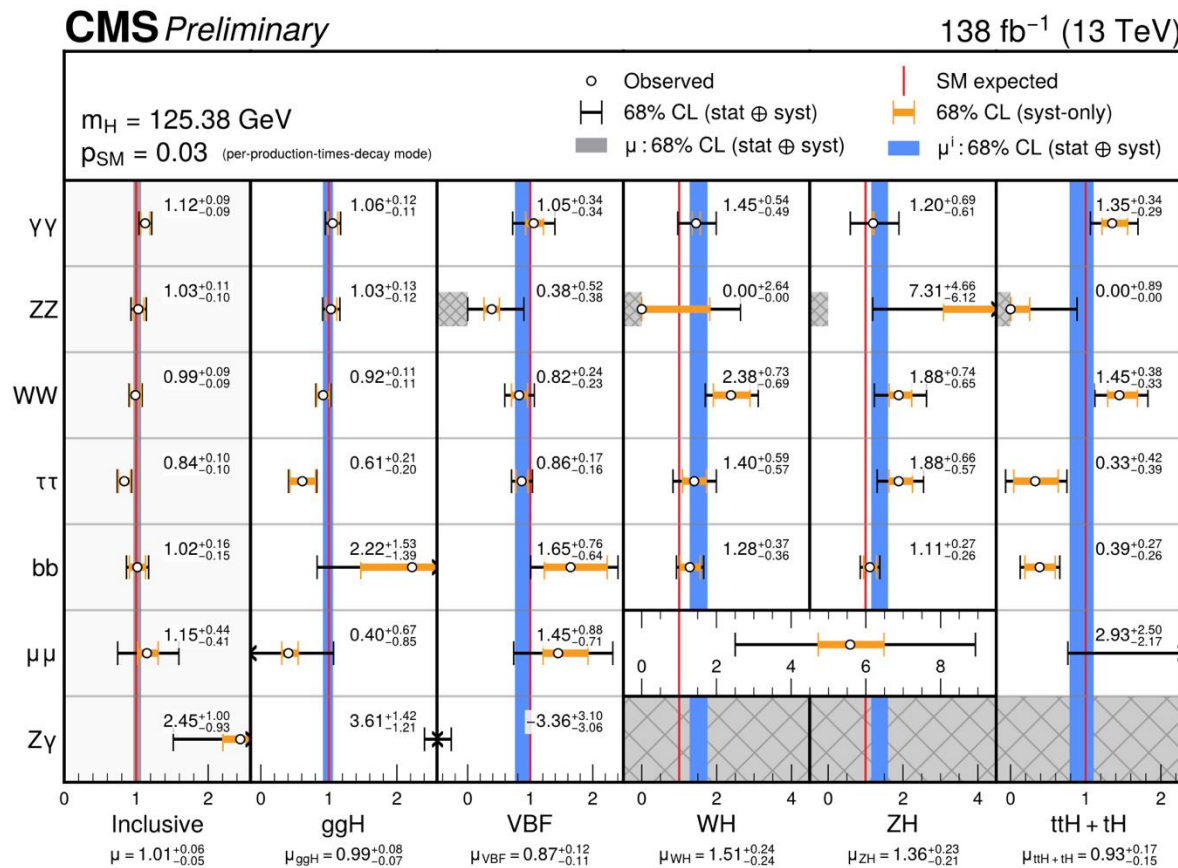

Signal strength dominated by theory uncertainties

$$\mu = 1.01^{+0.06}_{-0.05}$$

Coupling vs mass

Nature 607(2022)60, CMS-HIG-21-018

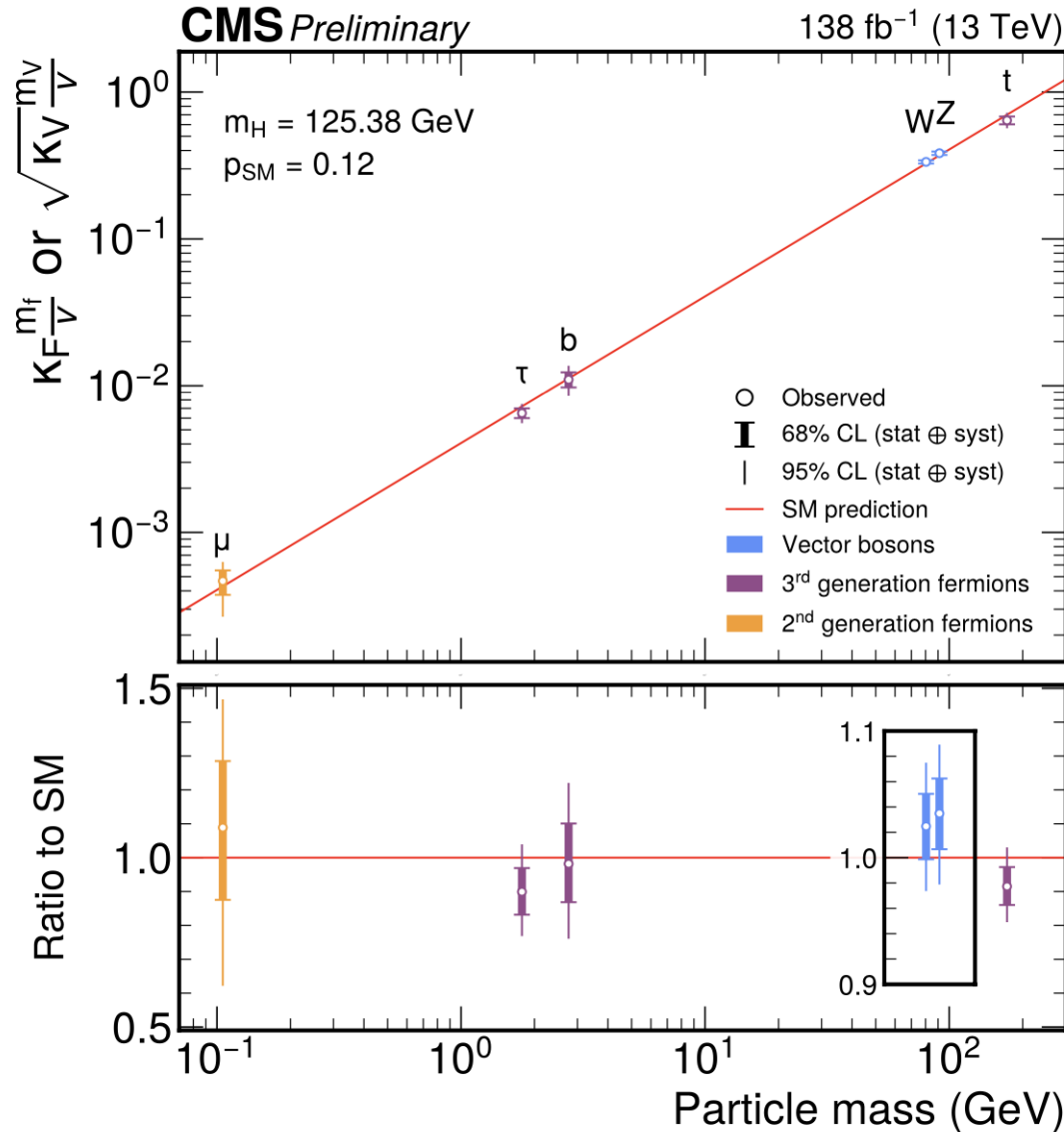

Rare decays: Z+photon

arXiv:2204.12945, PRL 132 021803

- New particles may contribute to internal loops
- Exploit different production modes
 - Tag $Z \rightarrow \ell\ell$ ($\ell=e,\mu$): most accessible experimentally

$$\sigma(pp \rightarrow H)\mathcal{B}(H \rightarrow Z\gamma) = 0.21 \pm 0.08 \text{ pb}$$

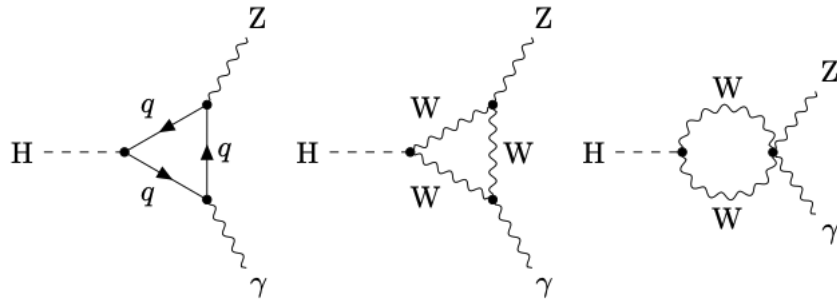

⇒ significance of 3.4σ (ATLAS+CMS)

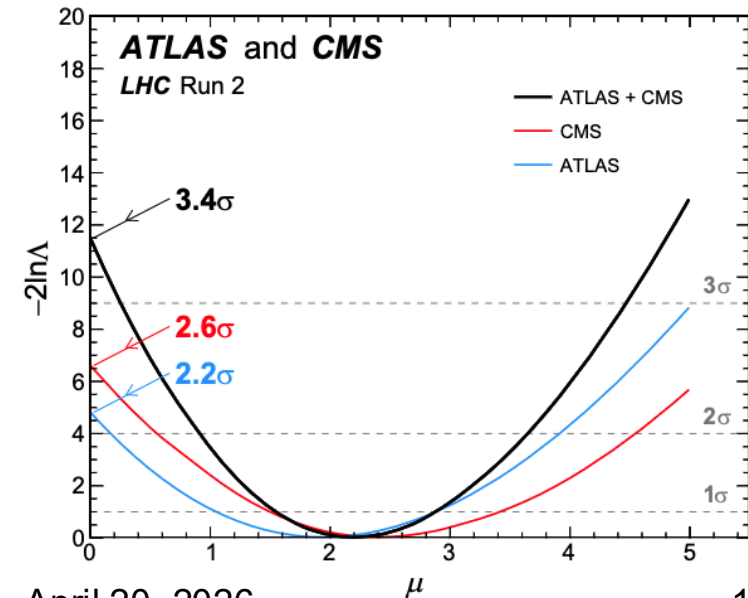
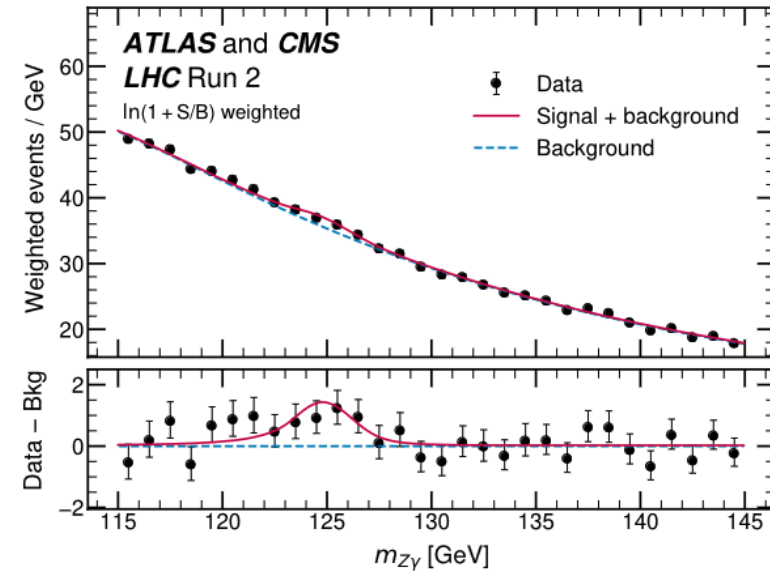

High mass: $H \rightarrow WW/ZZ$

JHEP 10(2015)144, HIG-16-033, HIG-16-034, arXiv:1912.01594, HIG-20-016

- Search for a heavy Higgs boson
 - $H \rightarrow ZZ \rightarrow 4l, 2l2\nu, 2lqq$
 - $H \rightarrow WW \rightarrow 2l2\nu, 2lqq$
- Optimized separately for VBF and gluon fusion production processes
- Combined upper limits at 95% CL on the product of $\sigma \times \text{BR}$ exclude a heavy Higgs boson with SM-like couplings and decays up to 1870 GeV
- Search interpreted in BSM scenario (heavy Higgs, heavy EWK singlet state)
 - evolution of signal strength of the singlet state with modified couplings/width wrt SM.
 - assume new scalar does not decay to any new particle

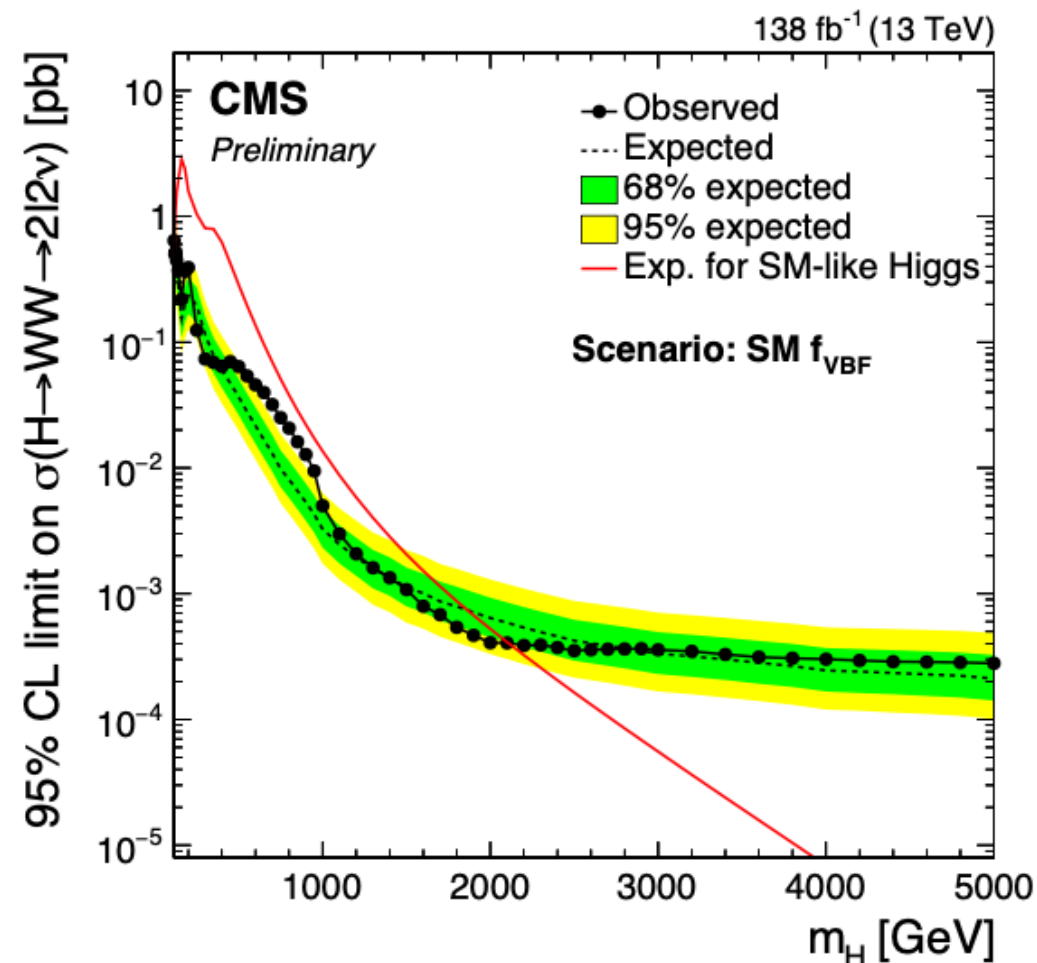

Heavy Higgs: dibosons

arXiv:1804.01939, JHEP03(2018)174, arXiv:1804.01126

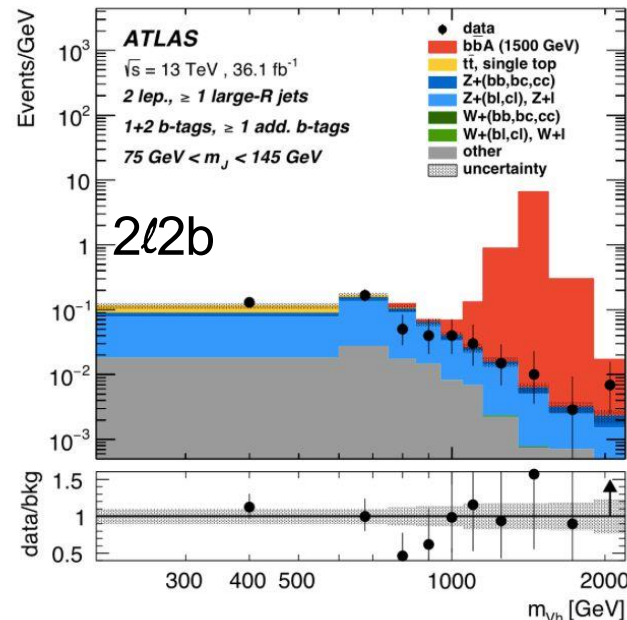
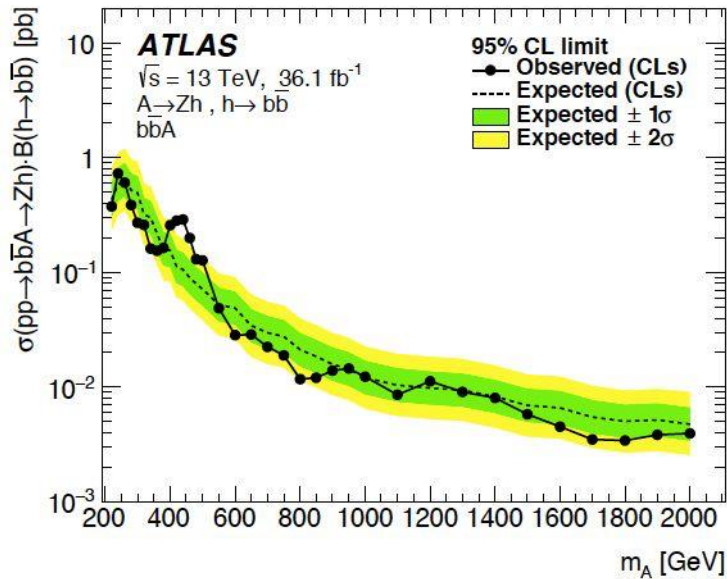
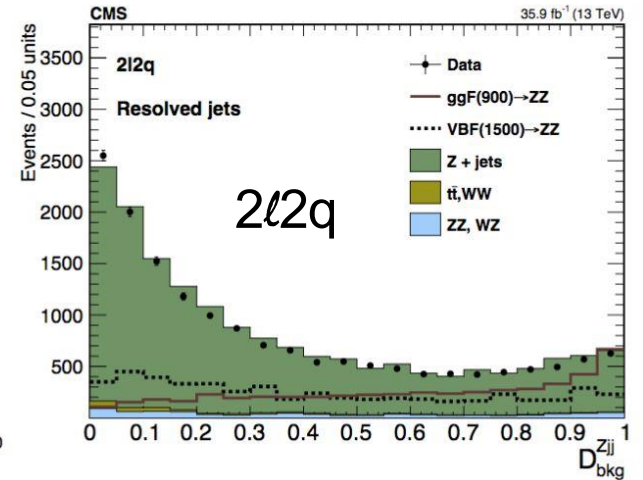
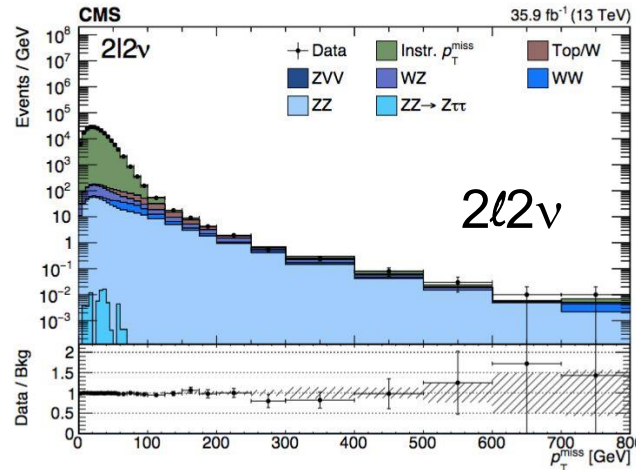
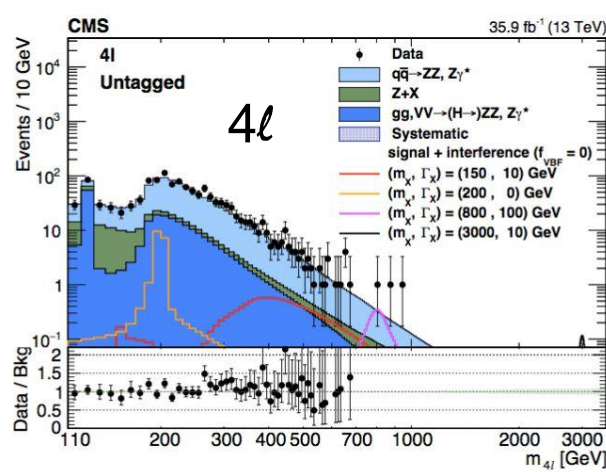

Hunting for a bump in the diboson mass spectrum

ttbar+Higgs

- ttbar produced in association with Higgs boson

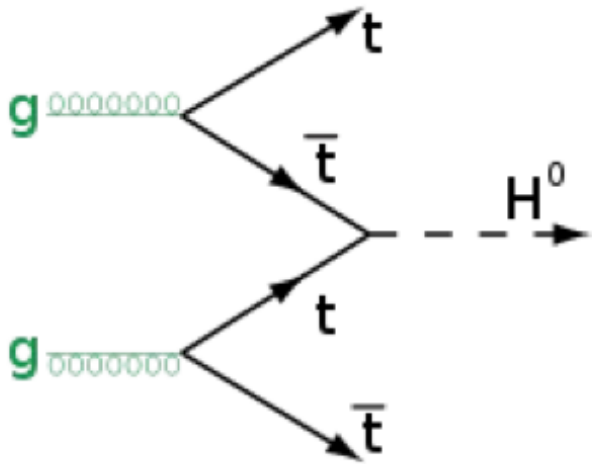

Cross section for ttH at the LHC:
 0.13 pb (8 TeV)
 0.61 pb (14 TeV)

ttH ~1% of total Higgs cross section

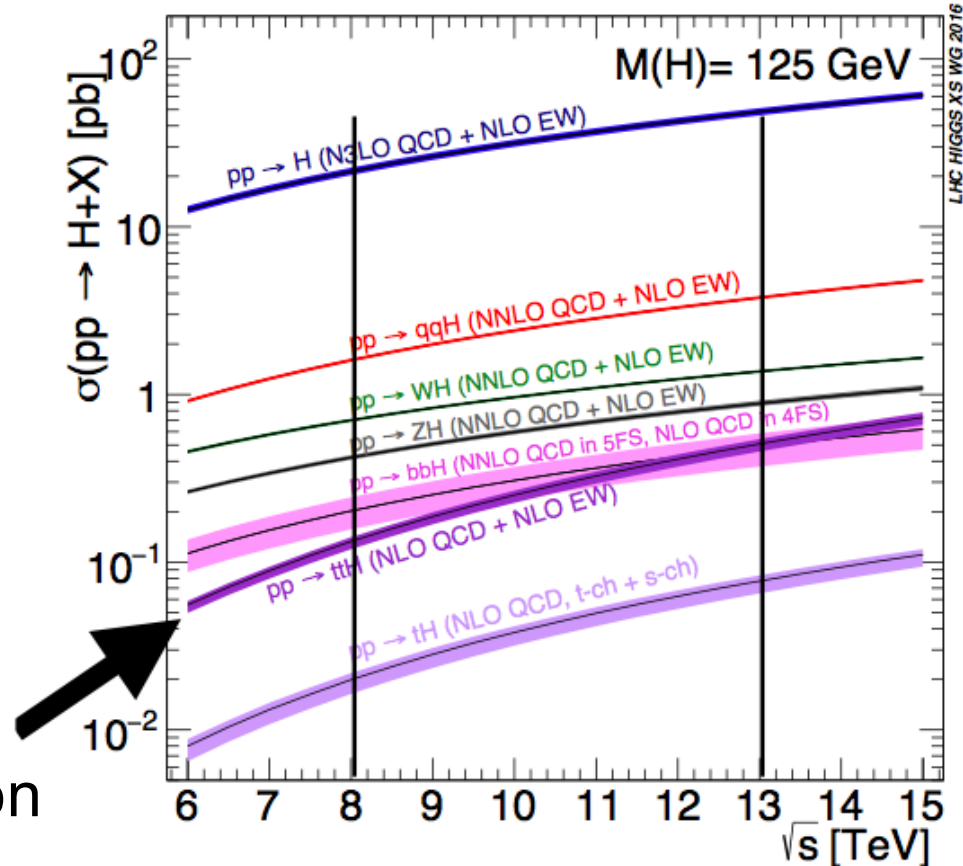

Higgs+Top: tH, ttH

arXiv:2011.03652, arXiv:2407.10896, [CMS summary](#)

- Crucial to SM tests and BSM searches
- Direct access to top-Higgs coupling
 - Also sensitive to CP-odd contributions in top-H coupling
- Challenge: small cross section wrt bkg
- tH and ttH production in many final states

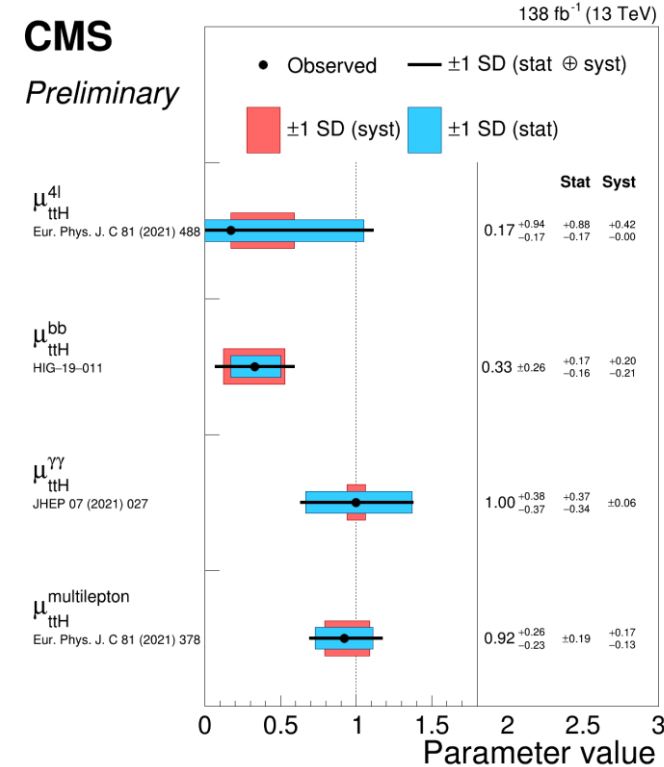
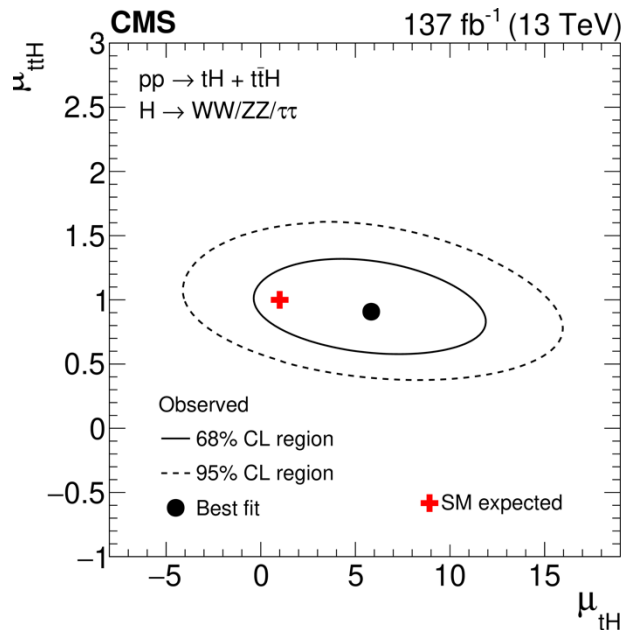
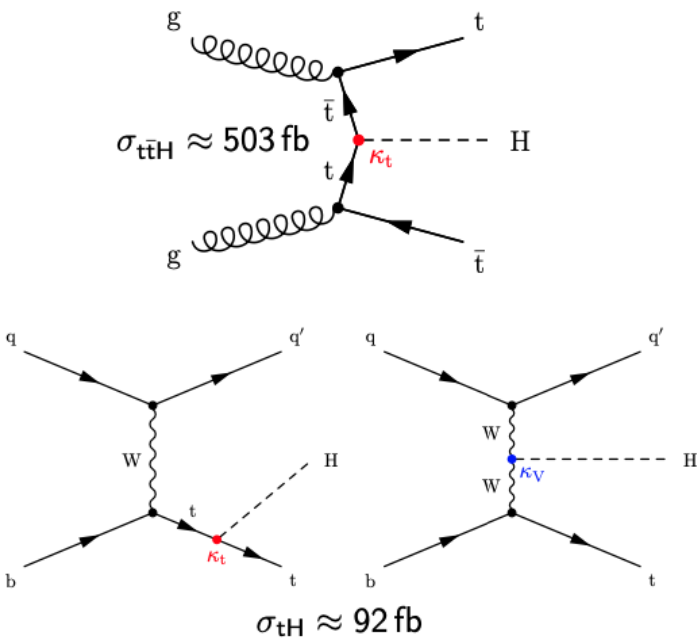

Extending searches

- Minimal Supersymmetric SM (MSSM)
 - Neutral Higgs: $\phi \rightarrow \tau\tau/bb/\mu\mu$
 - Charged Higgs
- Next-to-MSSM
 - Light pseudoscalar: $h \rightarrow aa$
 - Non-SM decays: $h \rightarrow 2a \rightarrow 4\tau/4\mu$
 - Heavy Higgs: $H \rightarrow h_{125}h_{125}$ or $A \rightarrow Zh_{125}$
- FCNC: $t \rightarrow cH$

Higgs sector in the MSSM

Higgs sector in SUSY contains two scalar doublets:

- 5 physical Higgs bosons
 - 3 neutral: CP-even $\phi=h, H$ CP-odd A
 - 2 charged H^\pm
- SM-like Higgs boson: h

Neutral Higgs ϕ decay modes:

- $\text{BR}(\phi \rightarrow b\bar{b}) \sim 90\%$
- $\text{BR}(\phi \rightarrow \tau\tau) \sim 10\%$
- $\text{BR}(\phi \rightarrow \mu\mu) \sim 0.1\%$

Two main production modes:

- $gg \rightarrow H$
- $b\bar{b}H$

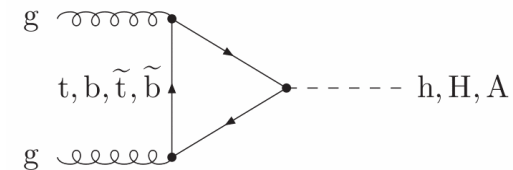
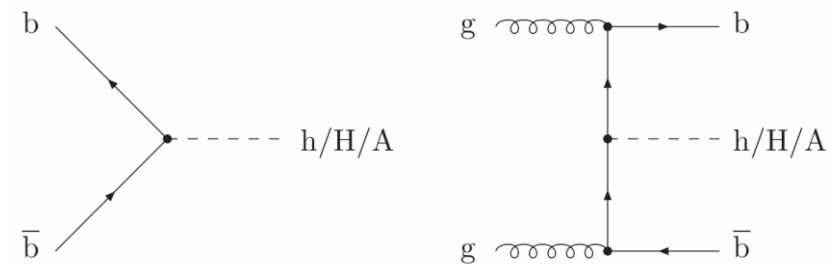

Neutral MSSM Higgs

JHEP 10(2014)212, arXiv:1803.06553, PRL 125(2020)051801

- Enhanced couplings of MSSM Higgs to down-type fermions (large $\tan\beta$)
 \Rightarrow increased BR to leptons and b-quarks

$$m_T^{\text{tot}} = \sqrt{m_T^2(p_T^{\tau_1}, p_T^{\tau_2}) + m_T^2(p_T^{\tau_1}, p_T^{\text{miss}}) + m_T^2(p_T^{\tau_2}, p_T^{\text{miss}})},$$

- Search for neutral MSSM Higgs boson
- 5 final states used: $\mu\tau_h$, $e\tau_h$, $\tau_h\tau_h$, $e\mu$, $\mu\mu$
 - Reconstruct tau-pair invariant mass
 - Split in b-tag/no b-tag categories to enhance sensitivity
- Main backgrounds: $Z \rightarrow \tau\tau$, QCD/W+jets, DY, ttbar, dibosons

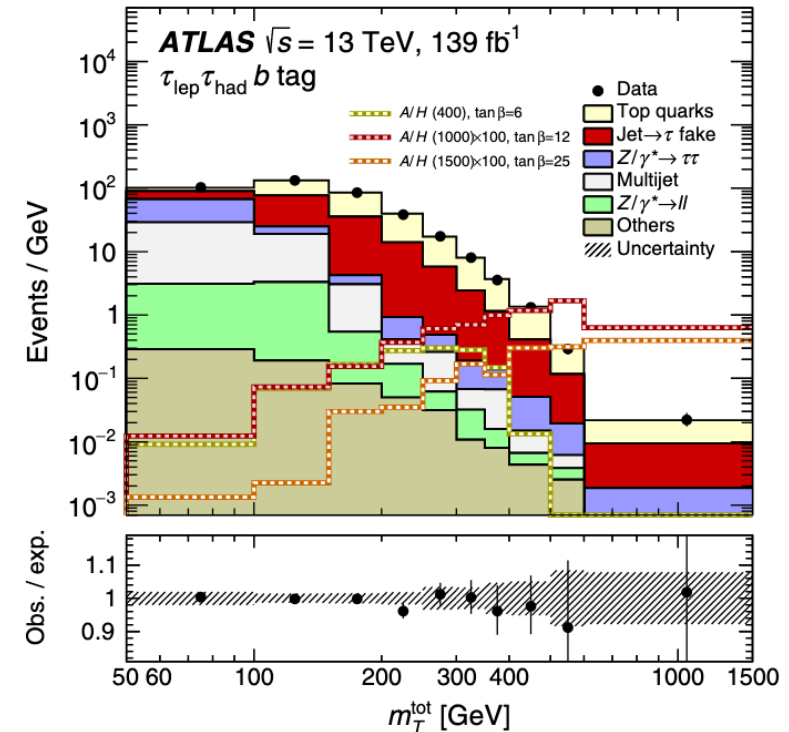
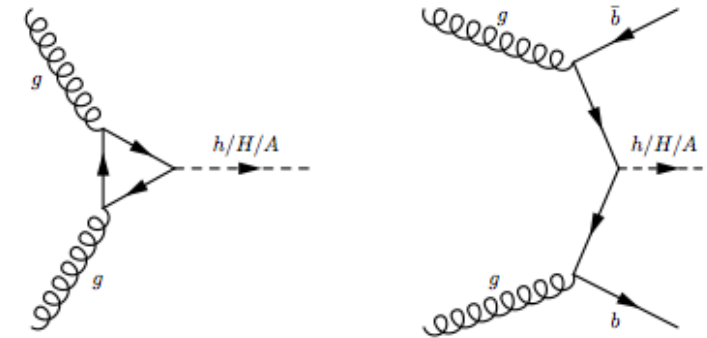

Neutral MSSM Higgs: $\phi \rightarrow \tau\tau$

arXiv:2208.02717

- Direct search: inclusive and b-tagged
- τ in both leptonic and hadronic decays

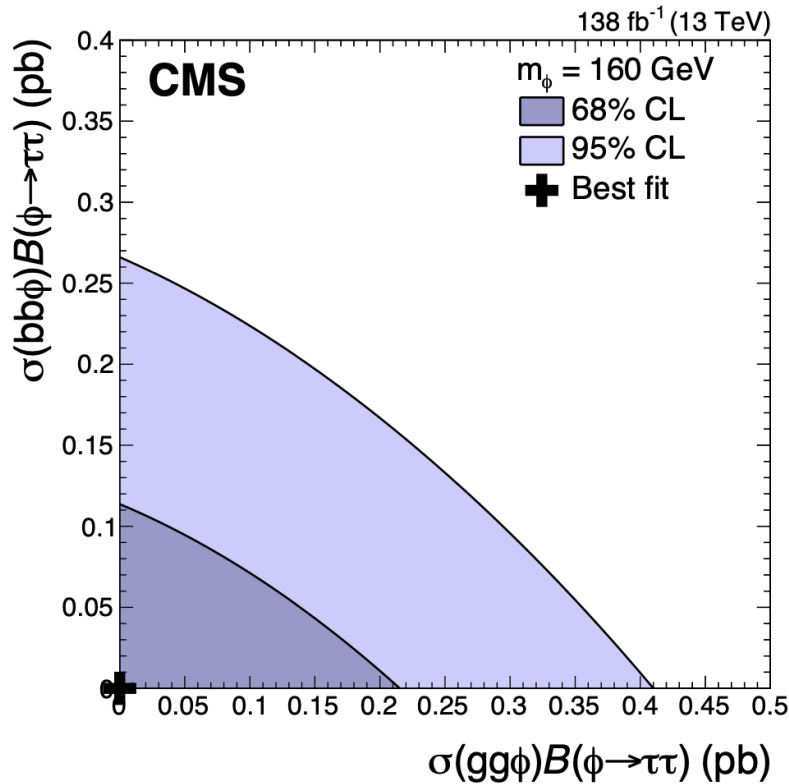

Model-independent limits by separating production modes

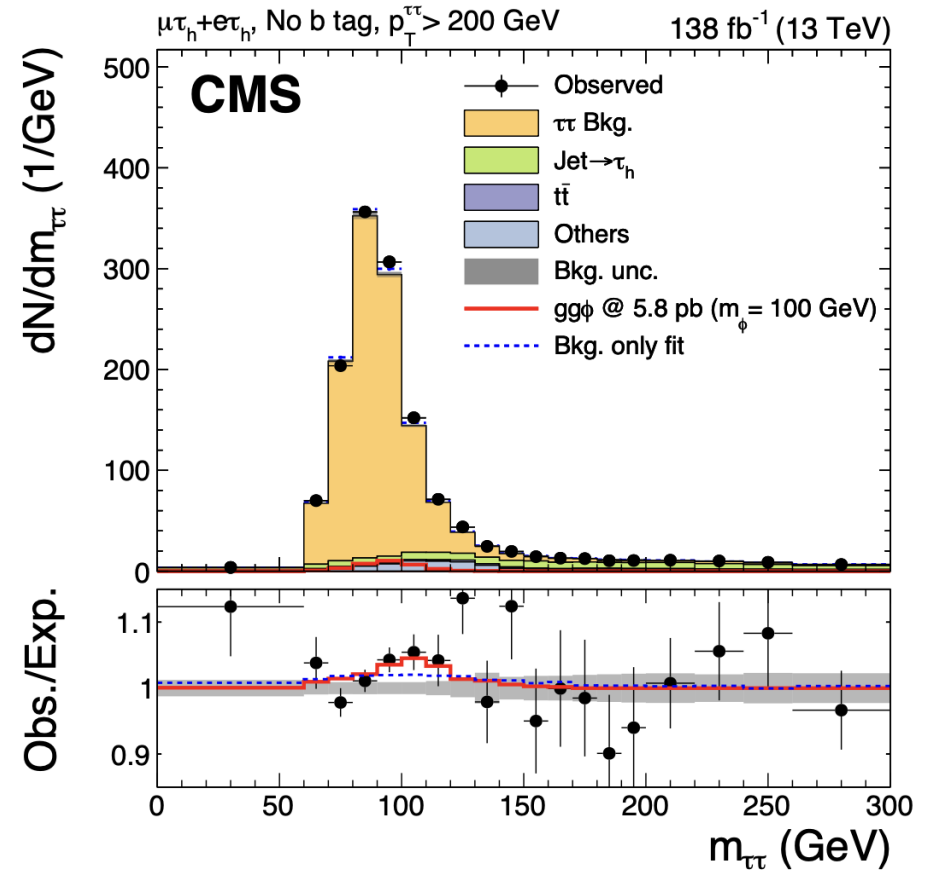

Some fluctuation over bkg expectations

Neutral MSSM Higgs: $\phi \rightarrow \mu\mu$

arXiv:1508.01437, JHEP07(2019)117

- Search for a $\mu\mu$ mass resonance
- Good mass resolution
 - full and clean reconstructed final state
- Split in b-tagged and non b-tagged categories to be sensitive to $gg \rightarrow \phi$ and $bb\phi$ production modes
- Main backgrounds: $Z(b\bar{b})$, $t\bar{t}$, WW

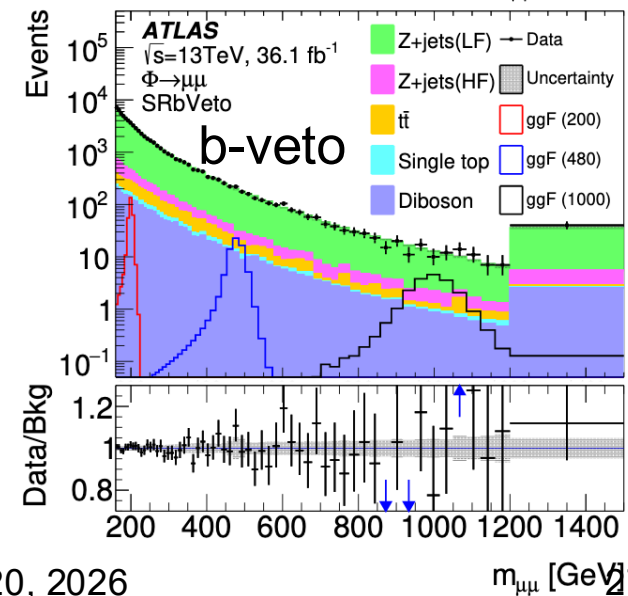
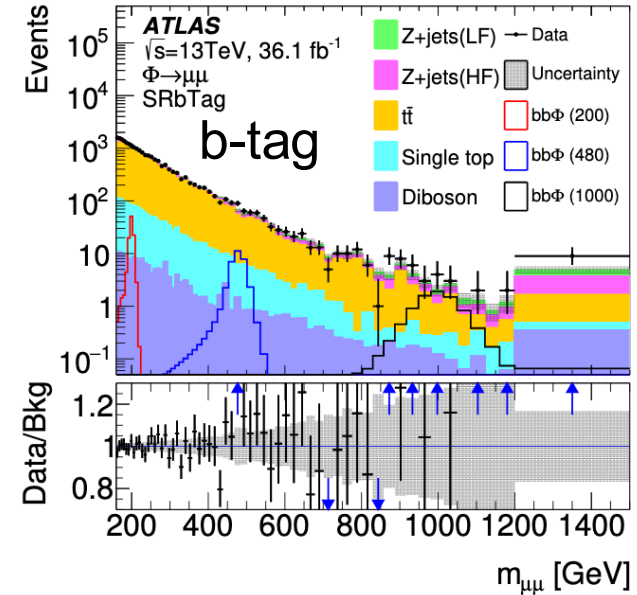
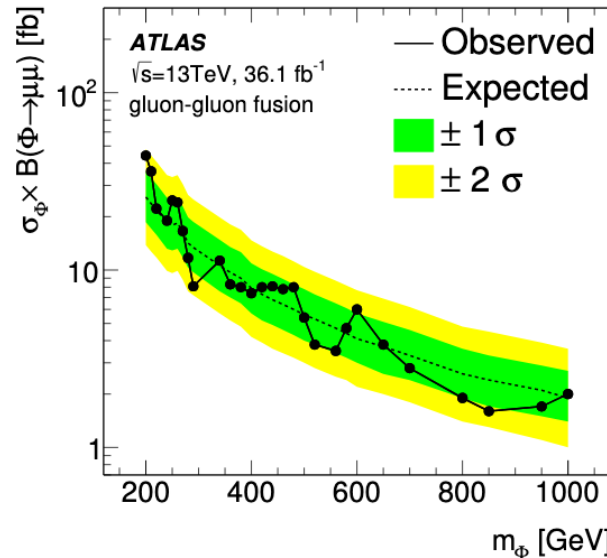
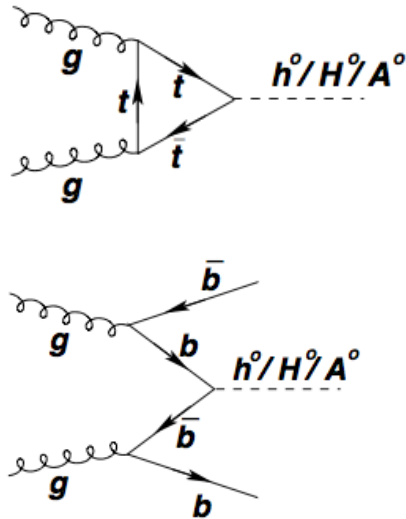

Charged Higgs

- If found, a clear indication of BSM
- Study non-SM Higgs in **two mass regimes**:
- $m_H < m_{\text{top}}$
 - Mostly produced in top quark decays
 - Large $\tan\beta$: $H^\pm \rightarrow \tau^+\nu$
 - Small $\tan\beta$ (<1): $H^+ \rightarrow c\bar{s}$
- $m_H > m_{\text{top}}$
 - Produced in gluon-gluon fusion
 - Main decays: $H^+ \rightarrow tb$, $H^+ \rightarrow \tau^+\nu$
- Main backgrounds: $t\bar{t}$, W +jets

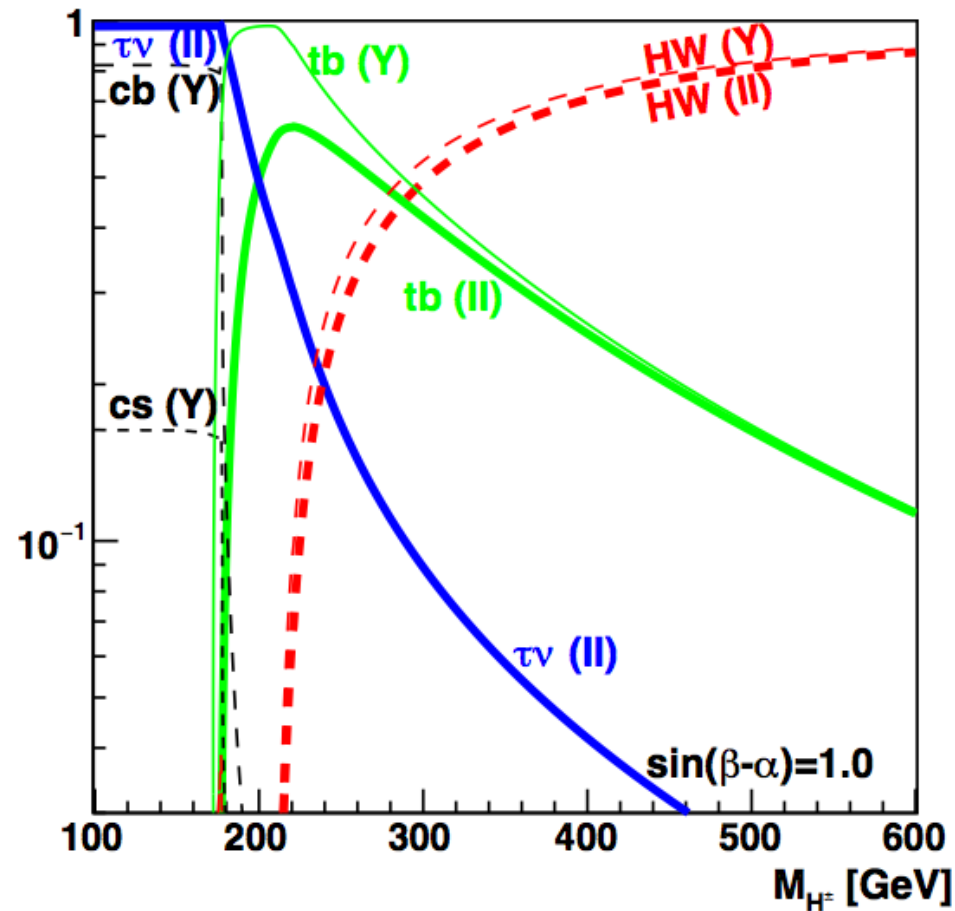

Charged Higgs (cont.)

- Different strategies for low- and high-mass searches
- tau+lepton, lep+jets, and $e\mu$ final states
- b-tagged jet categorization
- limited by statistics at high-mass

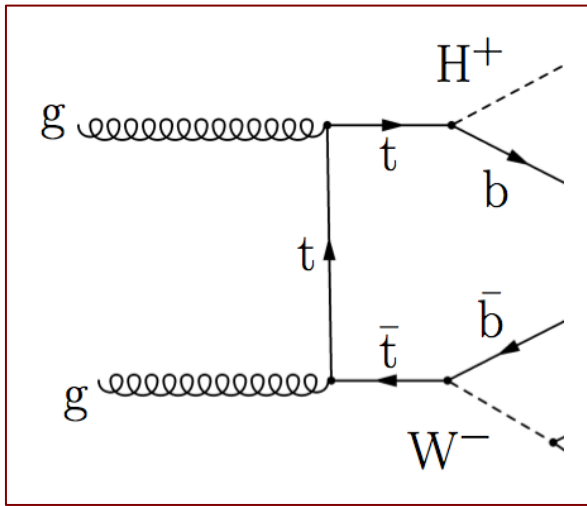
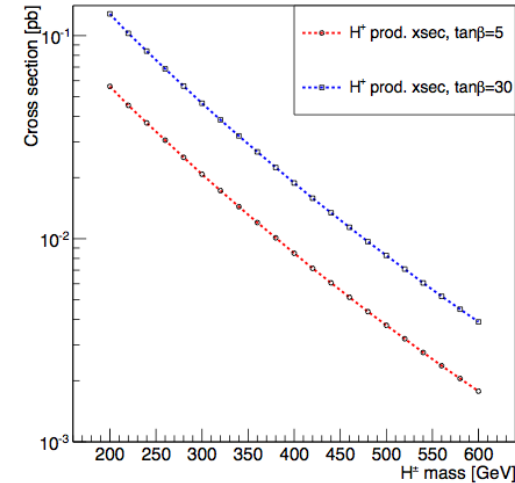

$$m_H < m_{top}$$

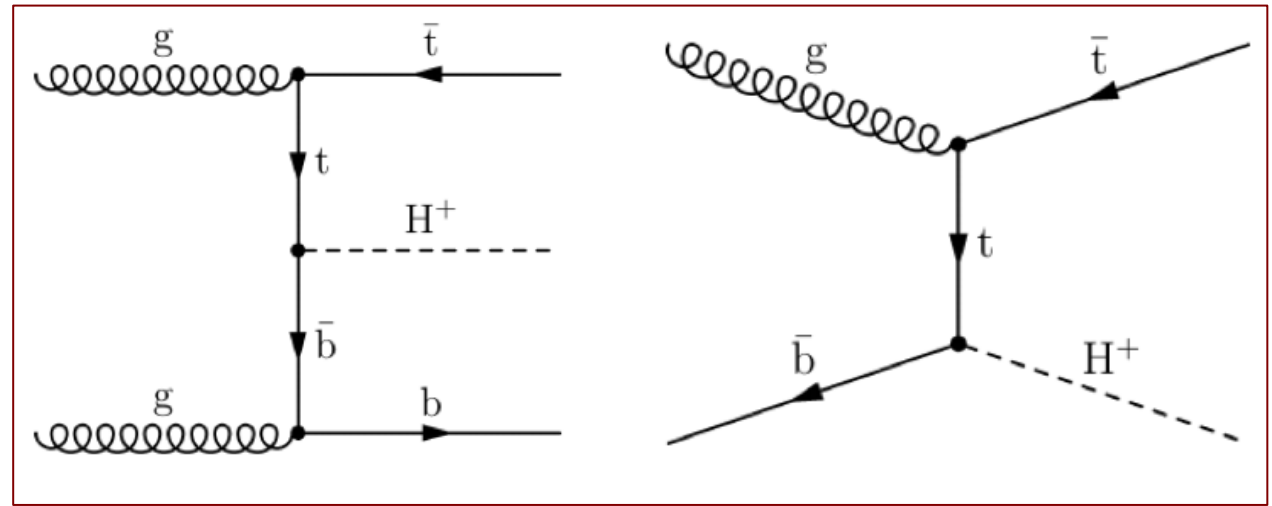

$$m_H > m_{top}$$

Charged Higgs and top quark decays

JHEP 07(2012)143, arXiv:1508.07774, HIG-16-031

- Look for charged Higgs in four final states:

- Tau+lepton (electron or muon)
- Dilepton (tau decays leptonically)
- lepton+jets
- Fully hadronic: tau+jets

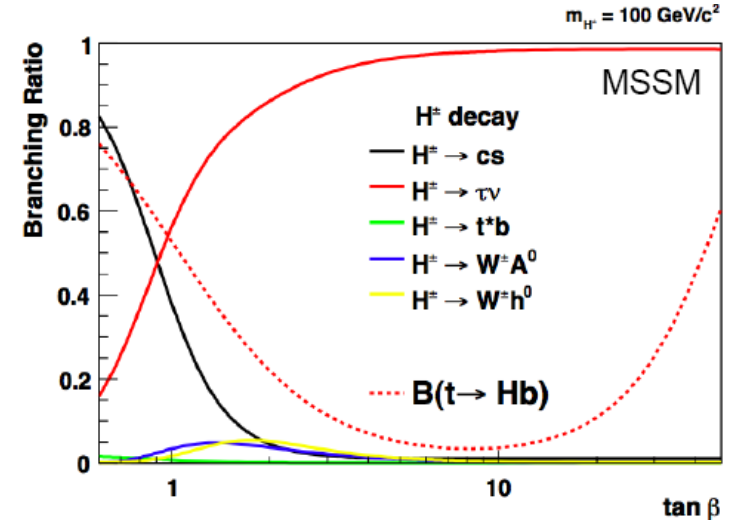

τ_h +jets

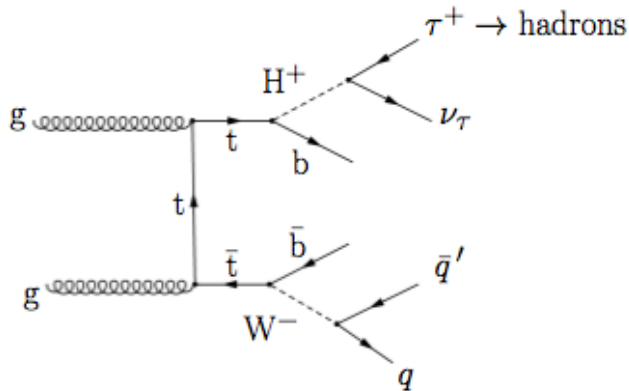

τ_h +lepton (e/μ)

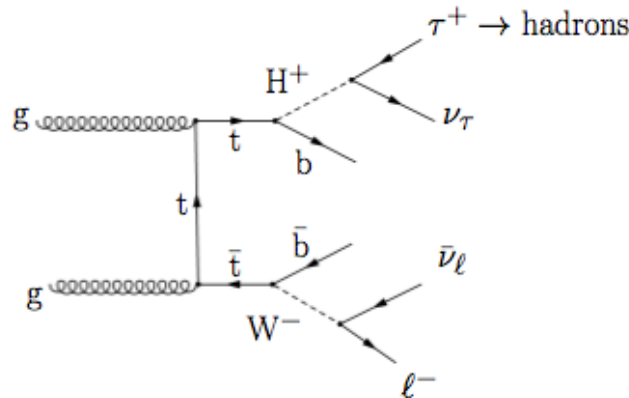

di-lepton (eμ)

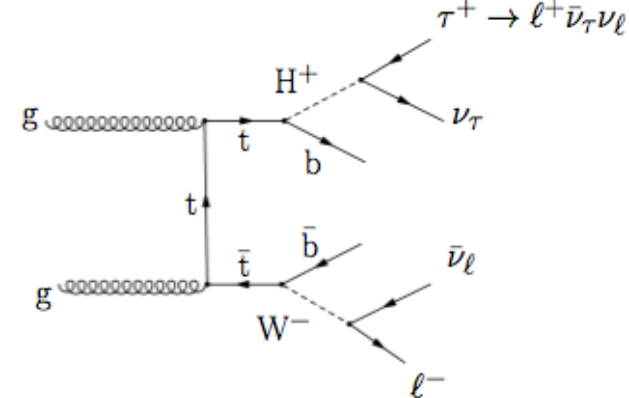

Looking at tau decays

CMS-HIG-12-052, arXiv:1903.04560

Low H^+ mass:

- Use R variable in the limit extraction: binned maximum-likelihood fit
- Tau fake component is data-driven, includes uncertainties

SM

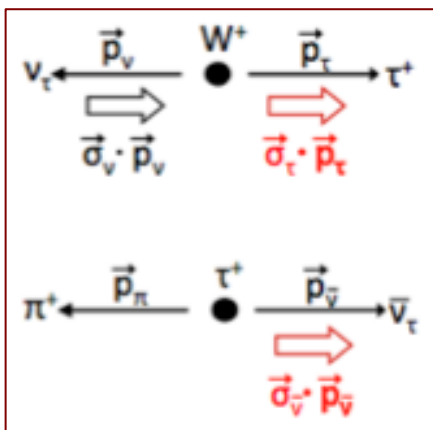

VS

BSM

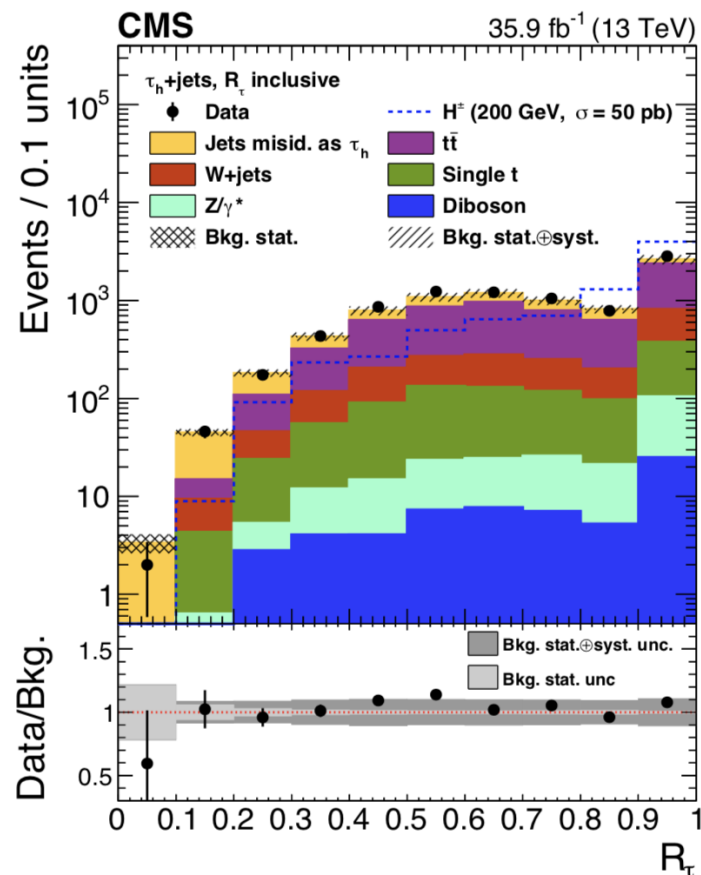
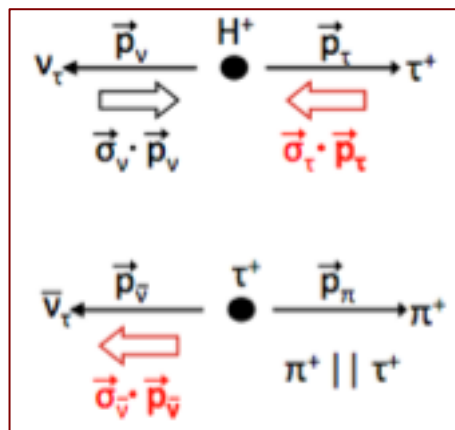

Charged Higgs: $H^+ \rightarrow \tau\nu$

arXiv:1903.04560

MSSM, high $\tan\beta$

- Final states: τ +jets, τ + ll , 0τ + ll
- 36 categories: incl. #jets, polarization $R=p_T(t_k)/p_T(\tau)$
- Cross section limits: 80-3000GeV

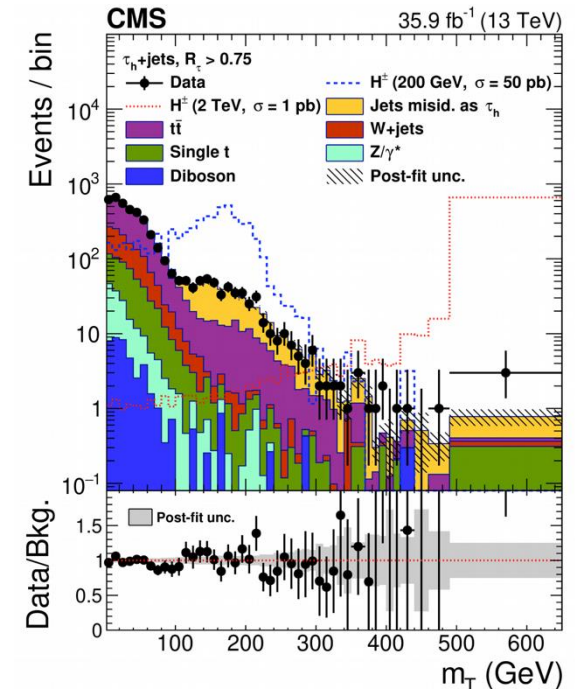
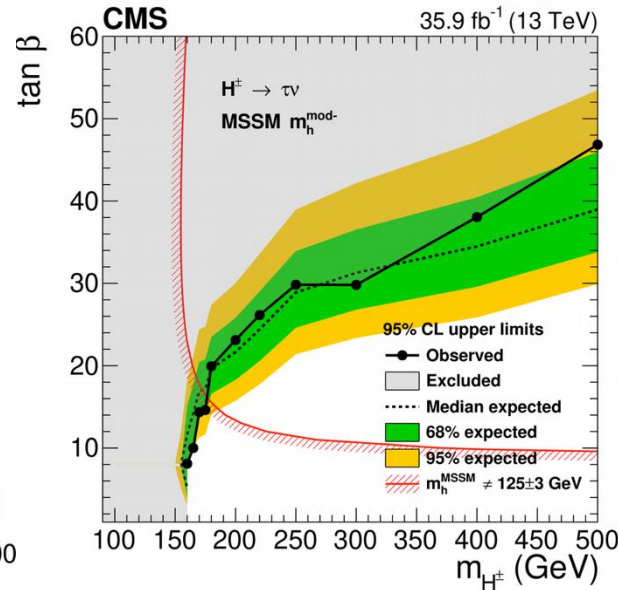
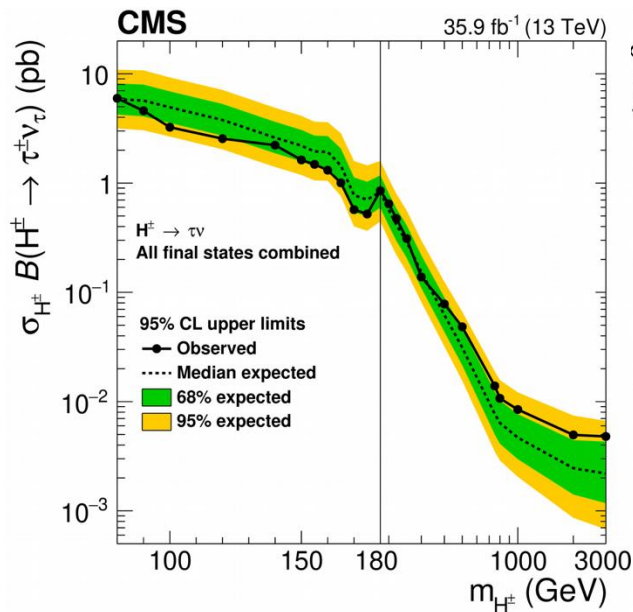
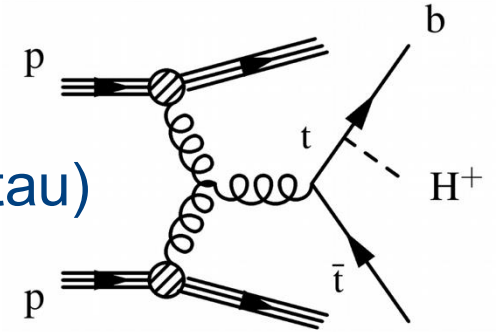

Charged Higgs: $H^+ \rightarrow tb$

arXiv:1908.09206, arXiv:2102.10076

MSSM, low $\tan\beta$

- Final states: 1ℓ and 2ℓ
- Categories (incl. #jets, #bjets)
- Discriminant vs $t\bar{t}b$ (BDT and DNN)
- Mass range: 200-3000 GeV

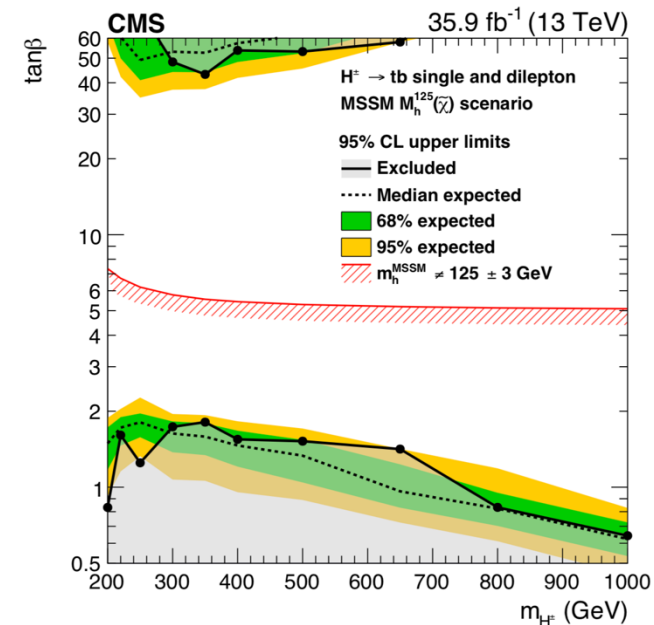
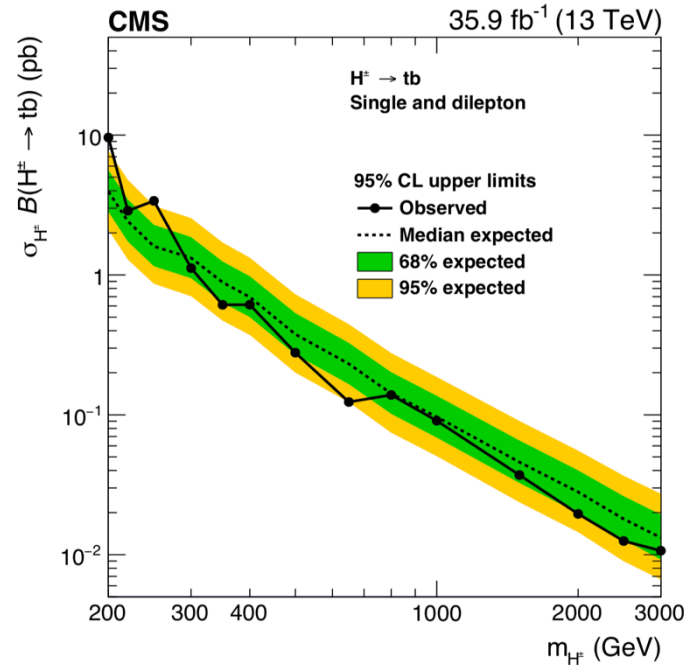
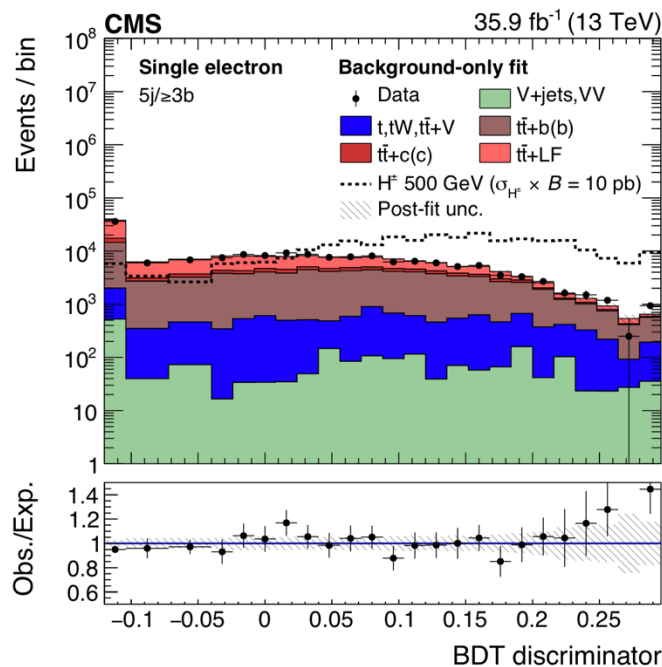
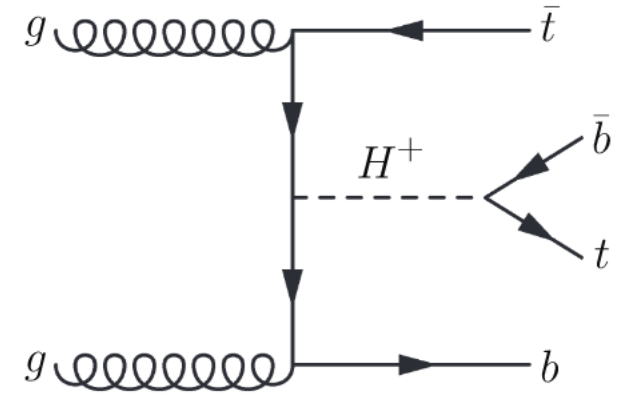

Charged Higgs: $H^+ \rightarrow tb$ (cont.)

arXiv:2207.01046

- Search for a H^\pm decaying to a heavy neutral Higgs boson H and a W
- data consistent with SM expectations
- Set limits:
 - H^\pm in the mass range 300-700 GeV, assuming $m_H=200$ GeV
 - Cross-section limit from 0.08 pb @ 300 GeV to 0.013 pb @ 700 GeV

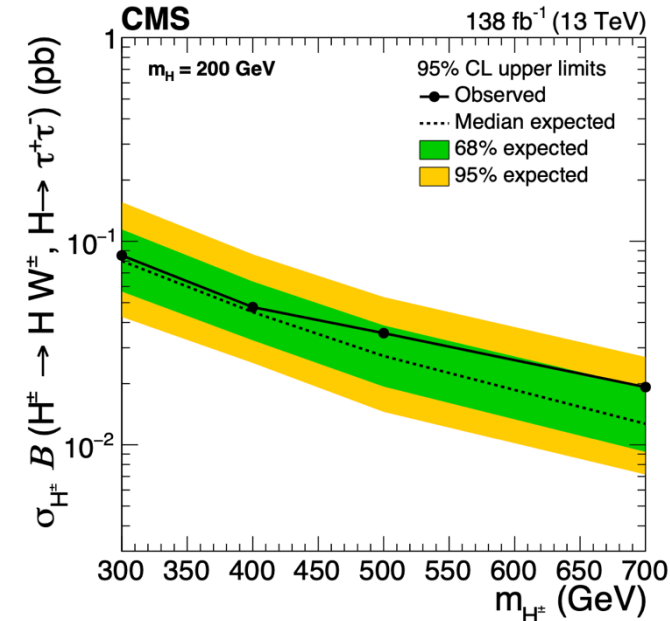
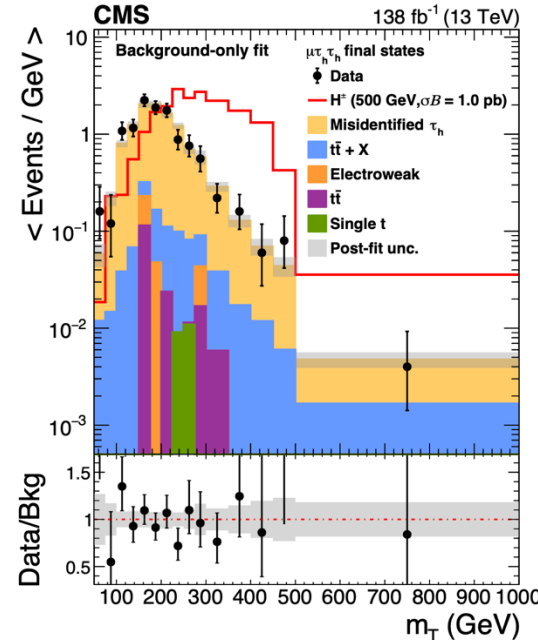
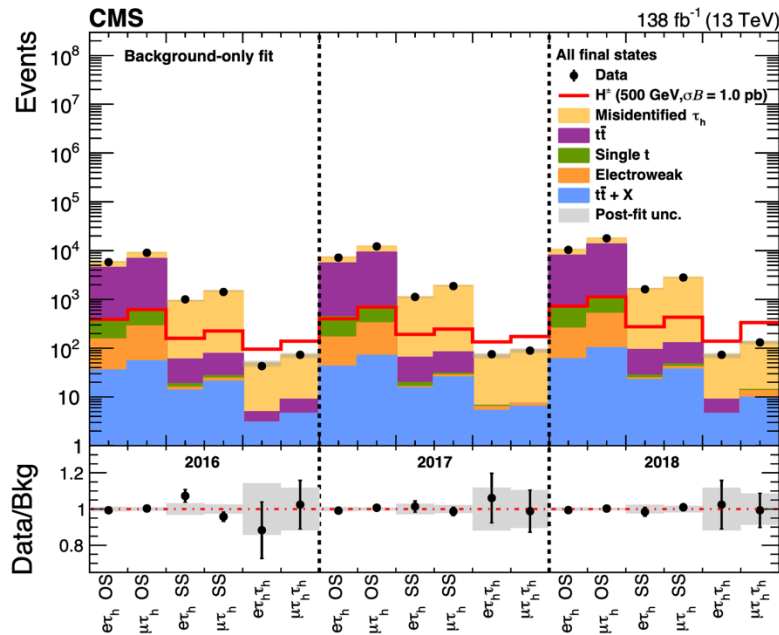
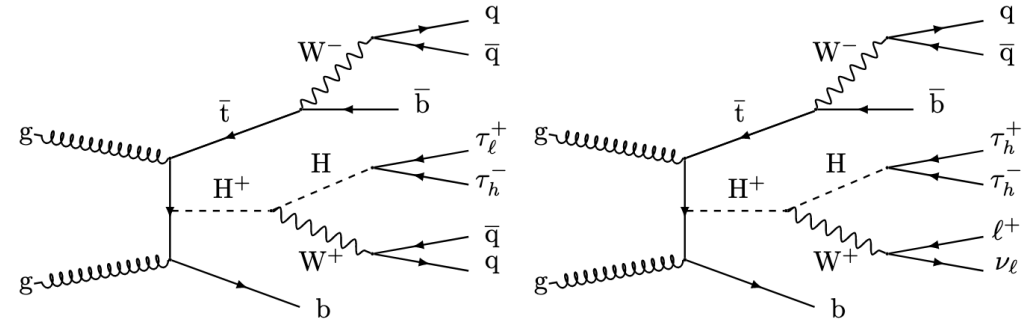

Doubly charged Higgs

HIG-16-036, arXiv:1710.09748

• Model

- SM extended with scalar triplet (Φ^{++} , Φ^+ , Φ^0)
- Triplet responsible for neutrino masses
- Search for doubly- and singly-charged
- DY pair production is most common
- SS lepton pair of any flavor combination

• Search with ≥ 3 leptons of any flavor

- Search for excess of events in one or more flavor combinations of SS lepton pairs

• Dilepton invariant mass as discriminant

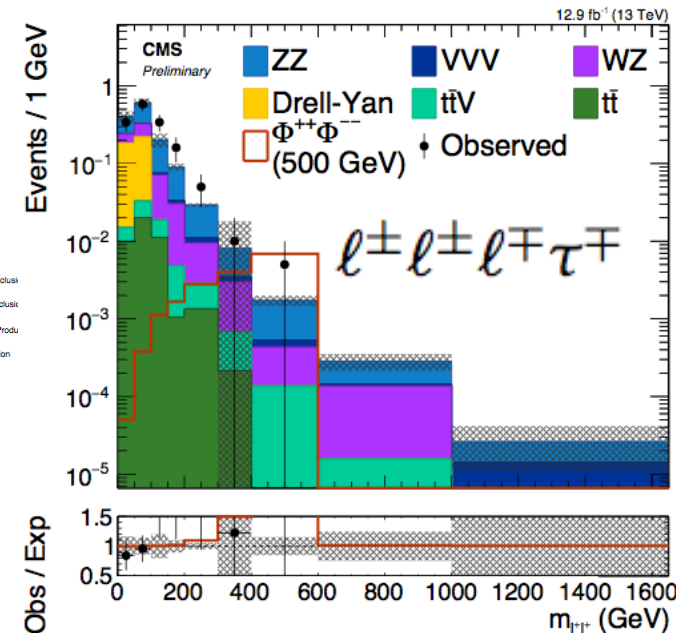
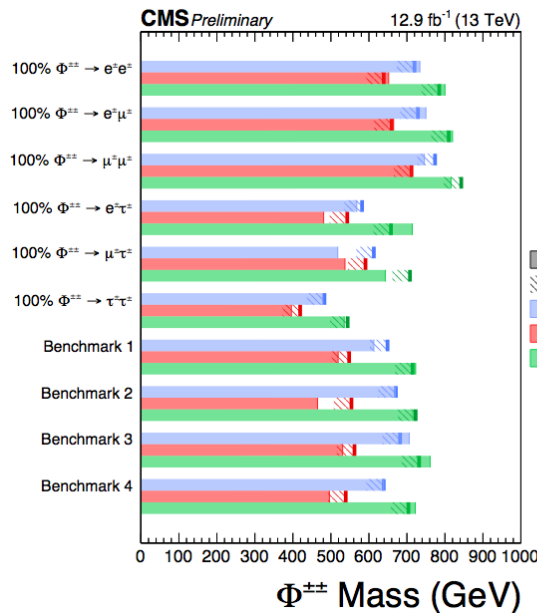
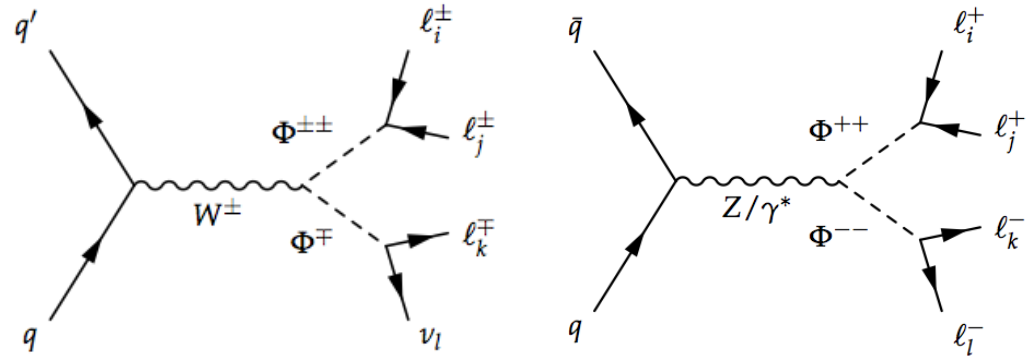

non-SM Higgs decay: $h \rightarrow aa \rightarrow 4X$

arXiv:2407.20425, arXiv:2403.10341

- Explore non-SM decays of a Higgs boson (h)
 - Higgs boson (h) can be SM or not
 - include production of two new light boson (a^0)
- Search for generic Higgs decays: $h \rightarrow 2a + X \rightarrow 4\mu + X$
 - Require two dimuon pairs with consistent masses
 - Limits on production rates, benchmark models
- (similar search: 4b final state)

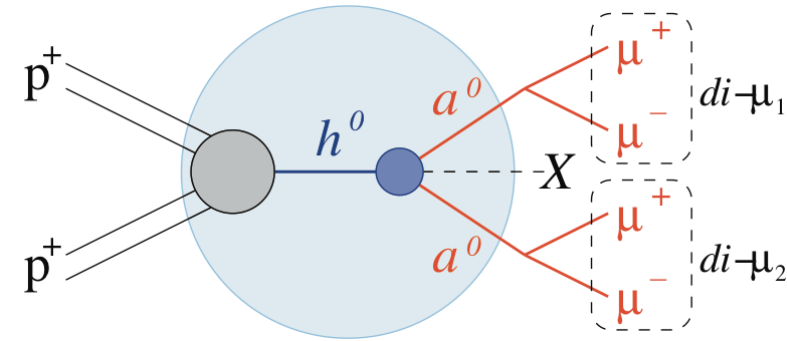

Results interpreted in NMSSM and dark SUSY

- Dark SUSY: h decay to pair of neutralinos (n_1): LSP
- NMSSM: add a complex singlet field (1 CP-even+1 CP-odd boson)

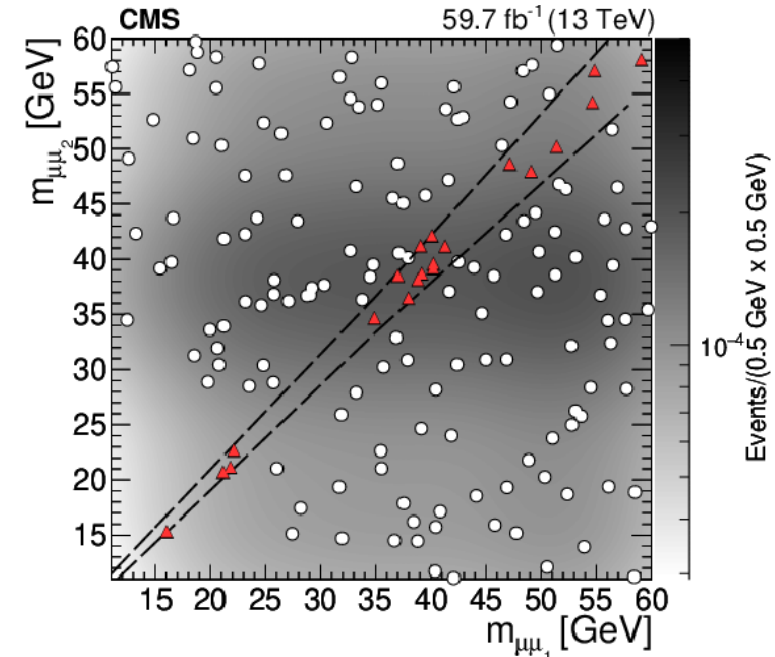
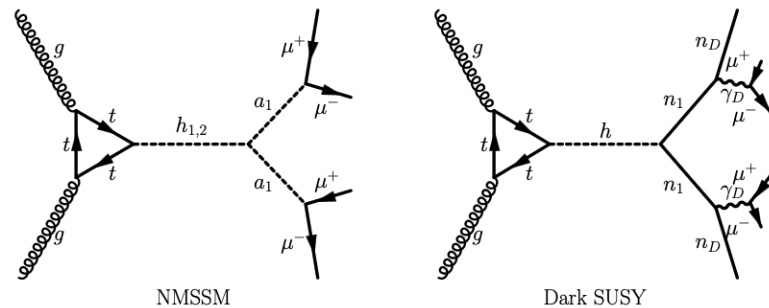

NMSSM and Dark SUSY Limits

PLB 726(2013)564, arXiv:1506.00424

Results interpreted in NMSSM and dark SUSY

- Dark SUSY: h decay to pair of neutralinos (n_1): LSP

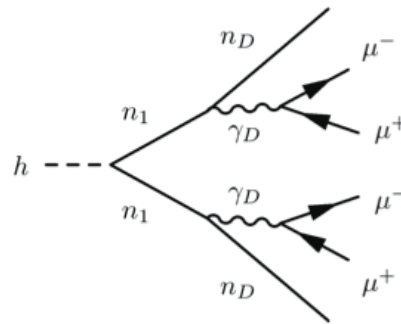
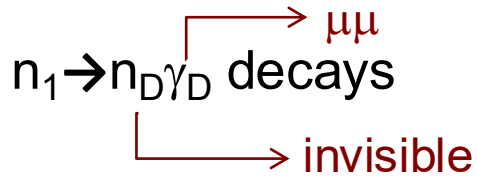

- NMSSM: Extend MSSM by adding a complex singlet field (1 CP-even+1 CP-odd boson)
- NMSSM: $h_{1,2} \rightarrow 2a_1$; $a_1 \rightarrow 2\mu$
- Compare to SM Higgs cross section

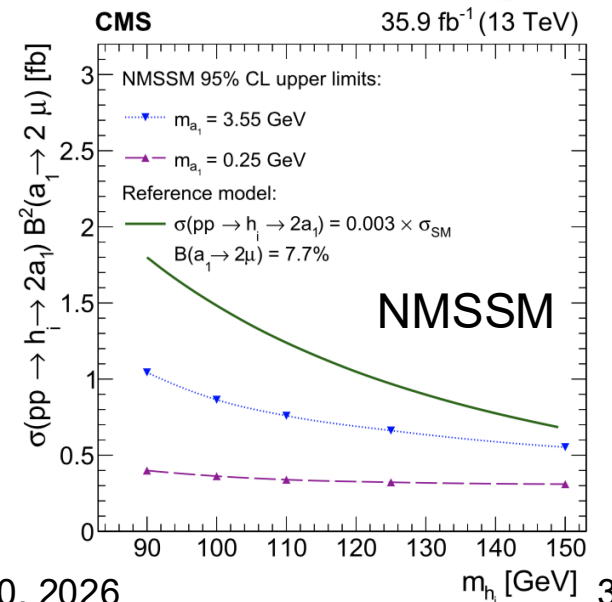
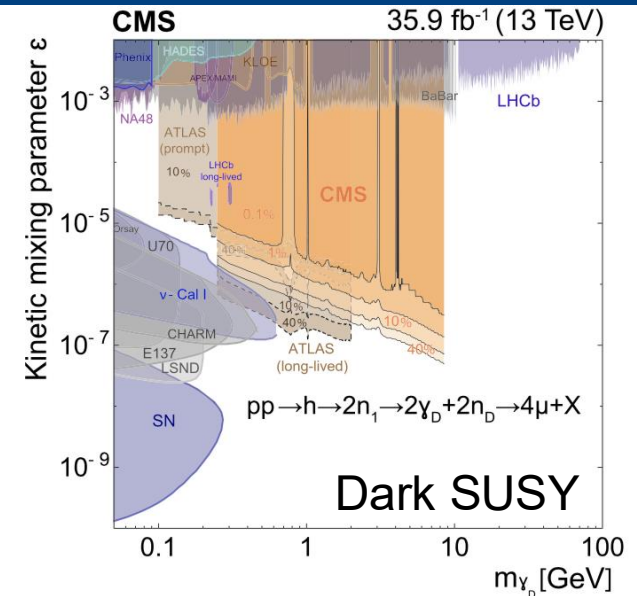

Exotic: $H \rightarrow AA \rightarrow 4\gamma$

arXiv:2209.06197, arXiv:2208.01469

- Exotic Higgs decay to light pseudo-scalar A
 - Motivated in BSM extensions (ALPs, DM, etc)
 - Merged $\gamma\gamma$ reconstructed as single γ -like object
 - Resolved and boosted topologies
- Model-independent search

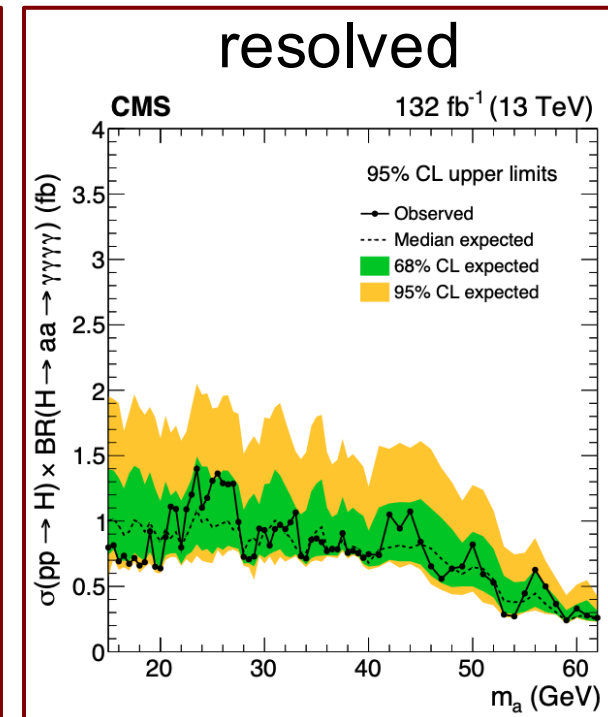
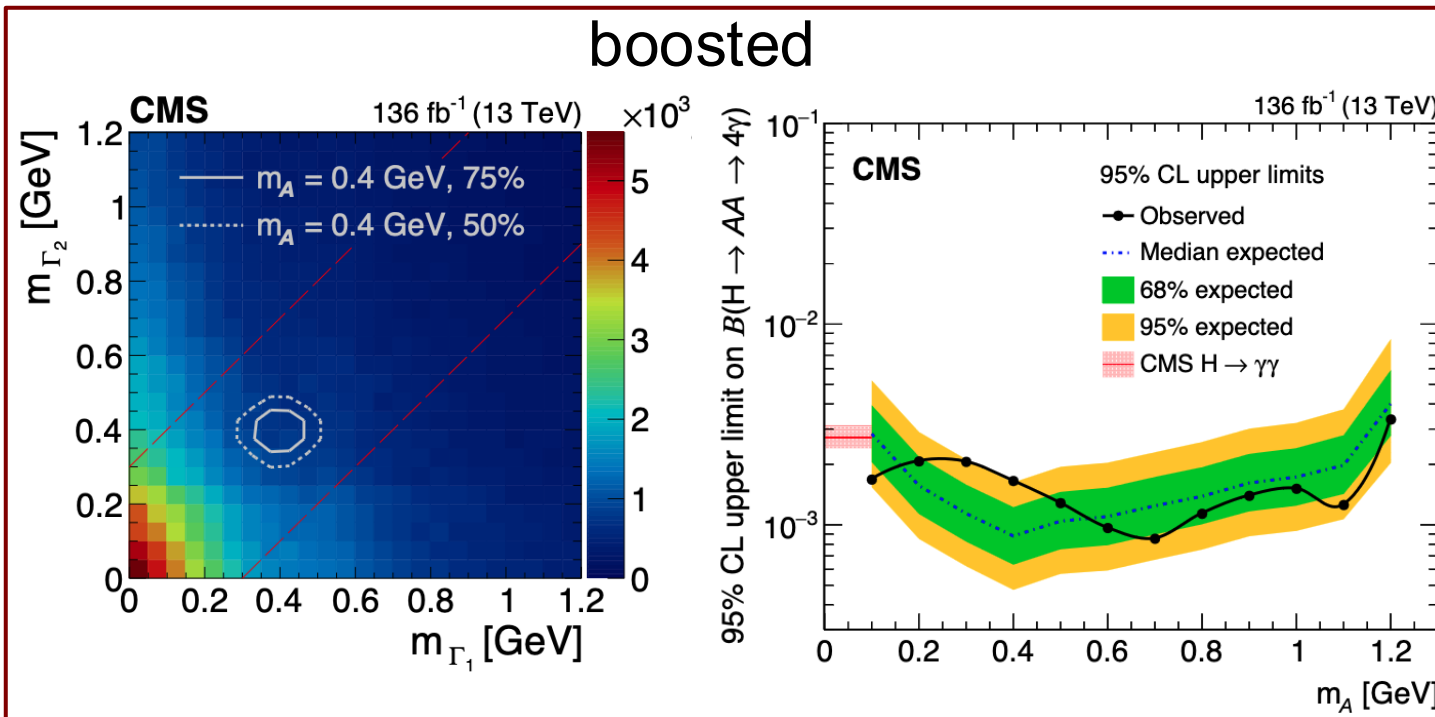
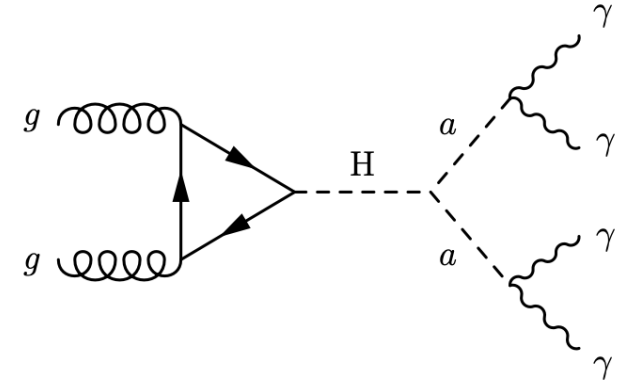

non-SM Higgs decay: $H_{125} \rightarrow 2h(a) \rightarrow 4\tau$

JHEP01(2016)079, PLB 800(2019)135087

- Search for **very light Higgs** in NMSSM
 - $H(125) \rightarrow$ light pseudoscalar (ϕ) bosons
 - One ϕ decays to a τ pair, the other to τ/μ pair
- Reconstruct μ -track invar. mass (m_1, m_2)
 - SS dimuon sample (removes DY)
 - bin in 2-dim distribution, fit signal and bkg
 - QCD bkg from control region

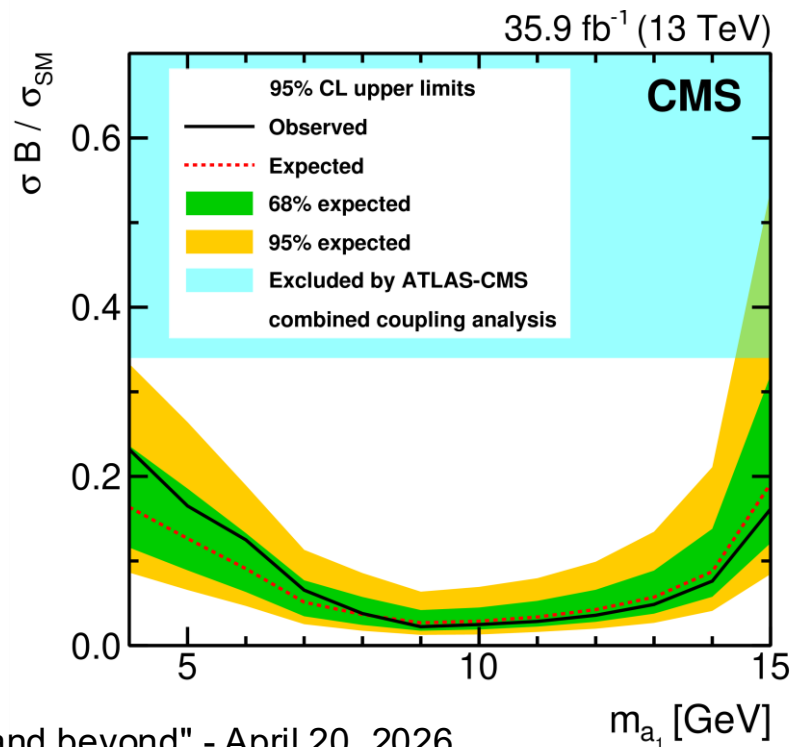
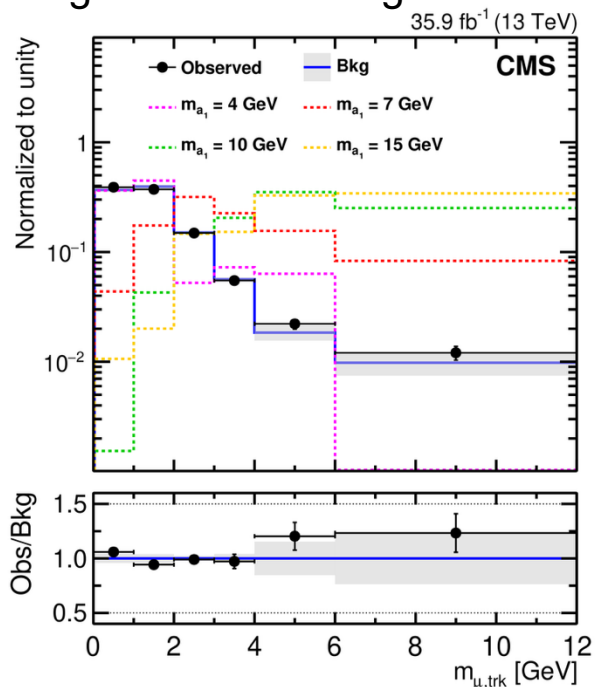
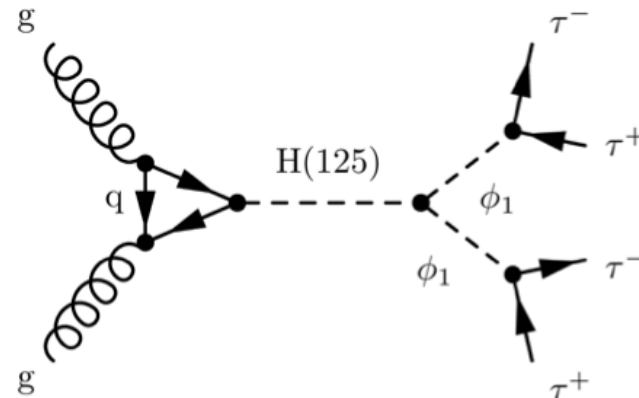

Summary for Higgs exotic decays

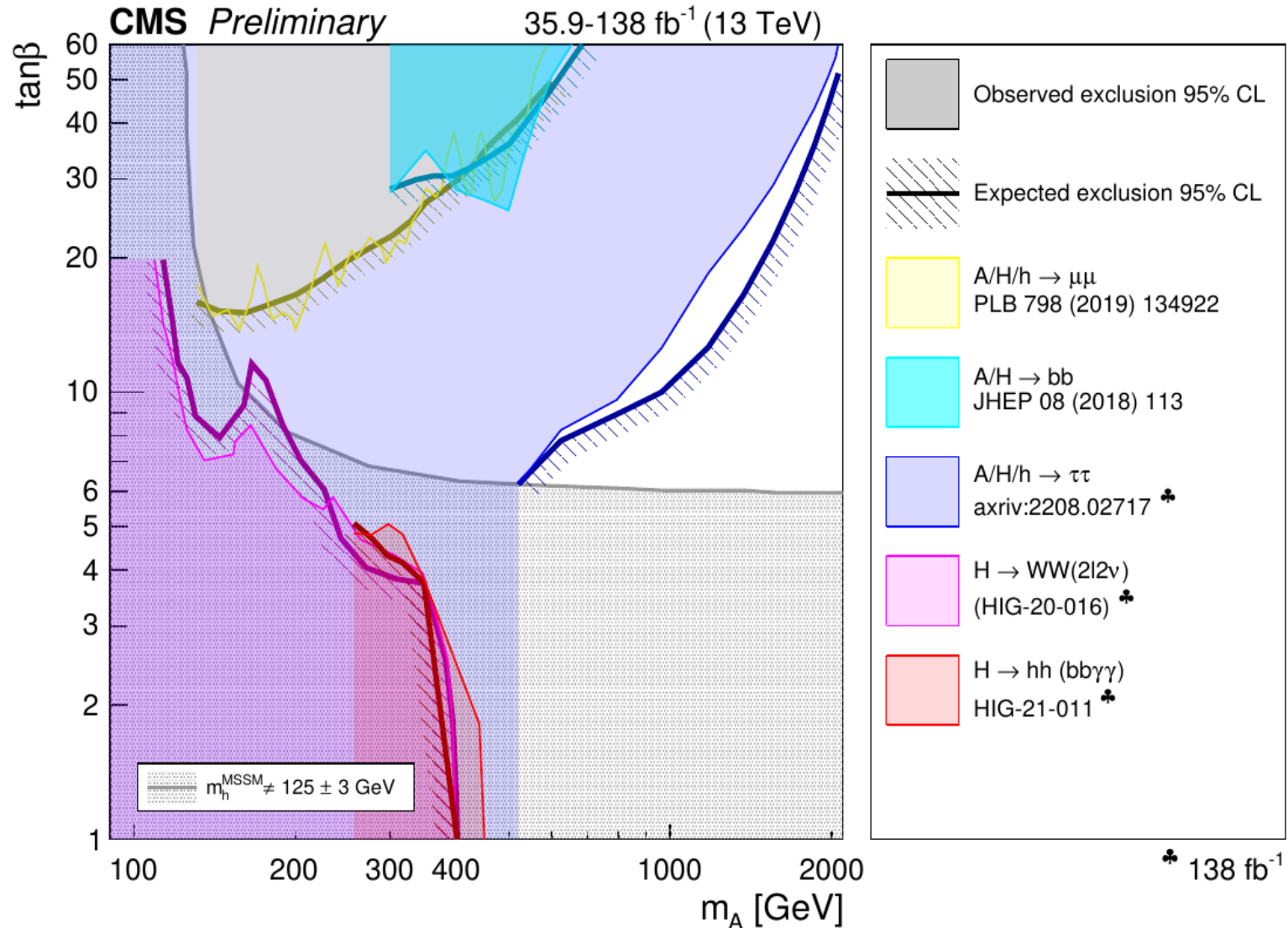

Heavy resonance search: ZH

CMS-B2G-23-008, B2G-23-006

- Search for heavy resonance: $Z(\ell\ell)H$
 - $H \rightarrow cc$ or $VV(4q)$
 - H as AK8 jet recoiling against Z
 - Jet substructure to discriminate vs bkg (DNN)
- Reconstruct invariant mass of ZH system

- $H \rightarrow t\bar{t}$ ≥ 2 b-tags
- Event categories: leptons, b-tags

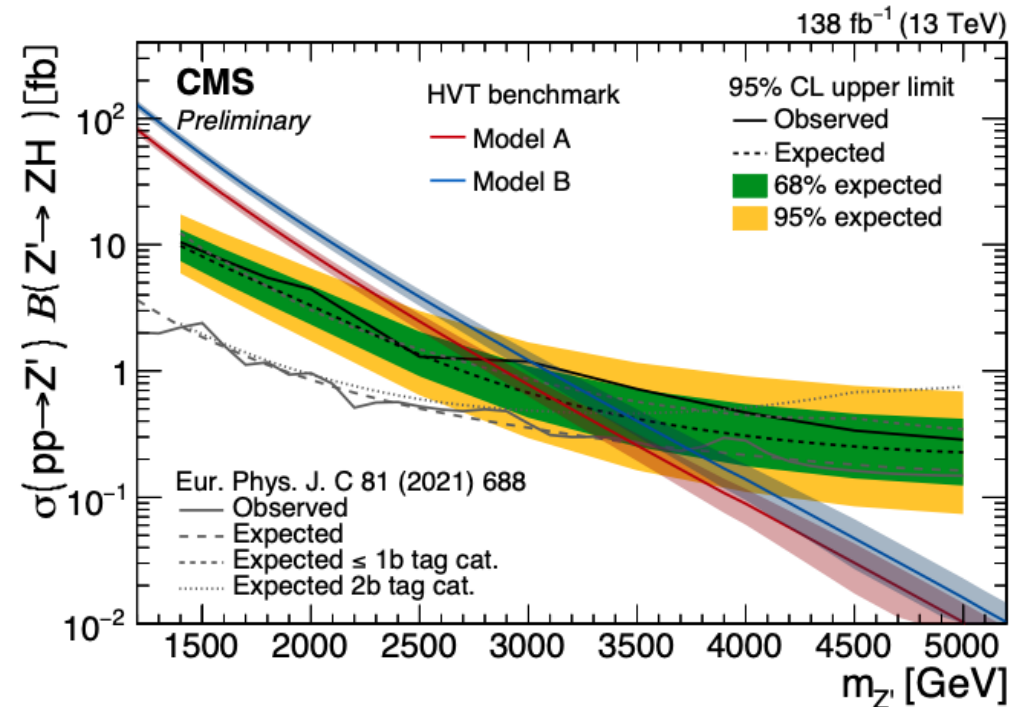
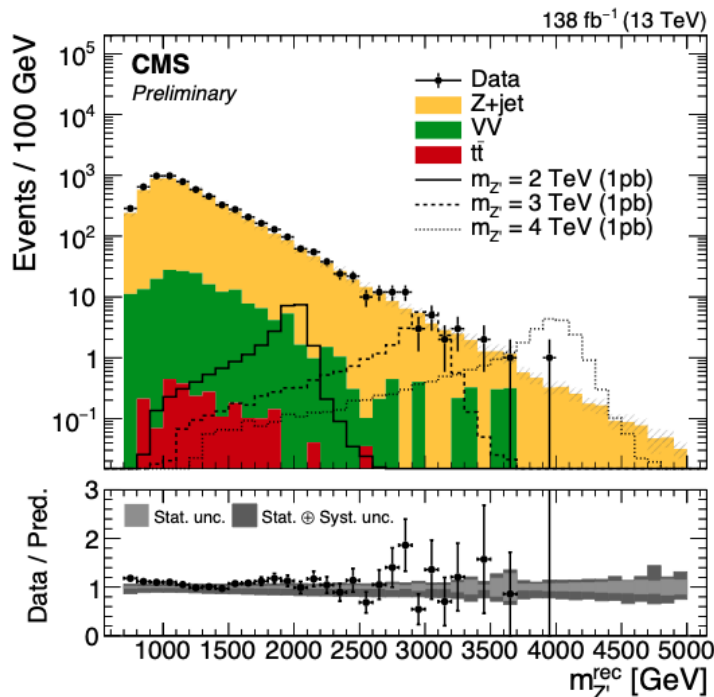
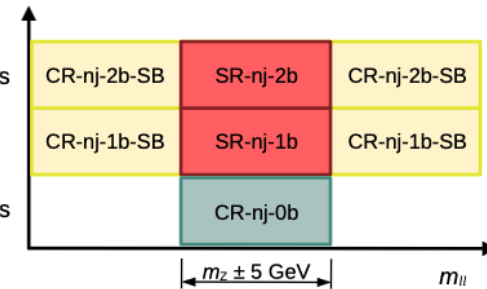

Low mass Higgs: $a(\rightarrow\tau\tau)bb$

arXiv:1511.03610, JHEP05(2019)210

- Low mass Higgs in the NMSSM
- Low mass pseudo-scalar ($a_1 \rightarrow \tau\tau$) in association with $b\bar{b}$: $a_1 b\bar{b} \rightarrow \tau\tau b\bar{b}$
- Similar strategy to $H \rightarrow \tau\tau$
- Search for a_1 masses below Z mass
- No evidence for signal
- Set limits: $\sigma \times B \sim 9-39$ pb

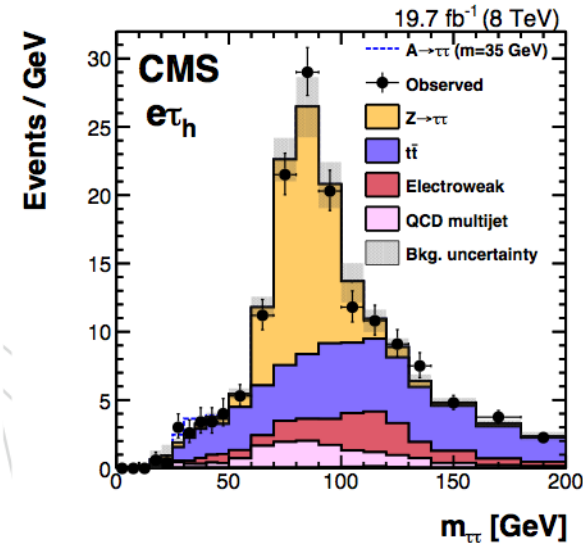
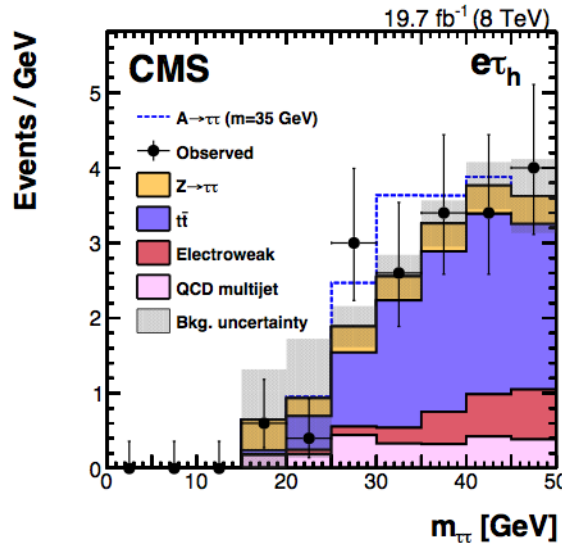
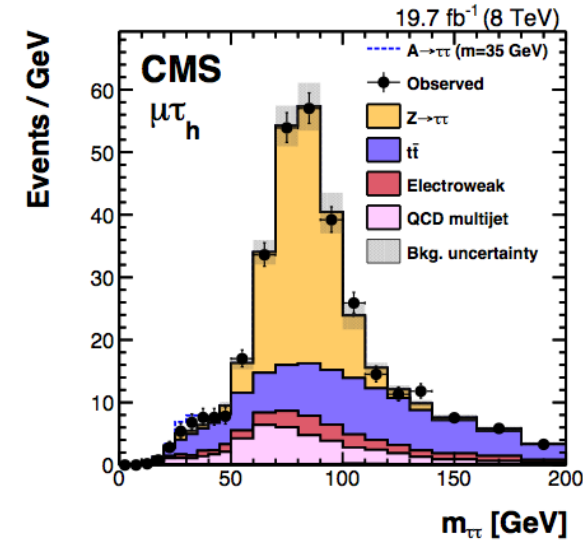
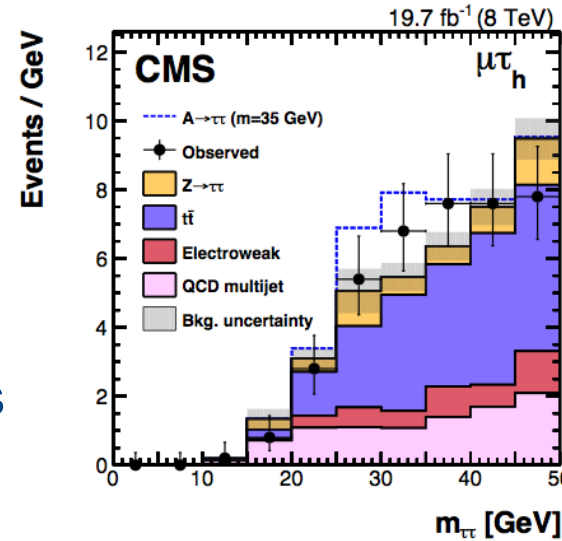
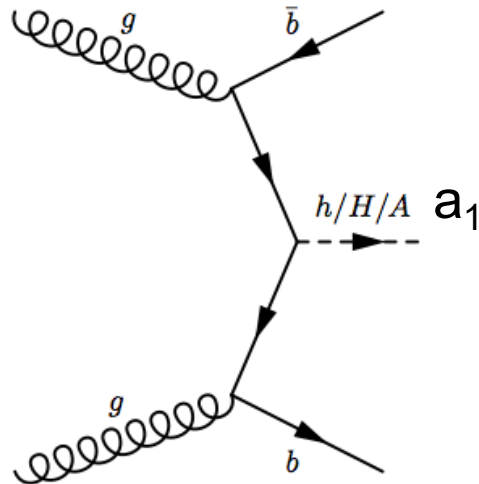

Low mass Higgs: $a(\rightarrow\tau\tau)bb$

arXiv:1511.03610, JHEP05(2019)210

- Low mass Higgs in the NMSSM
- Low mass pseudo-scalar ($a_1 \rightarrow \tau\tau$) in association with $b\bar{b}$: $a_1 b\bar{b} \rightarrow \tau\tau b\bar{b}$
- Similar strategy to $H \rightarrow \tau\tau$
- Search for a_1 masses below Z mass
- No evidence for signal
- Set limits: $\sigma \times B \sim 20-0.3$ pb

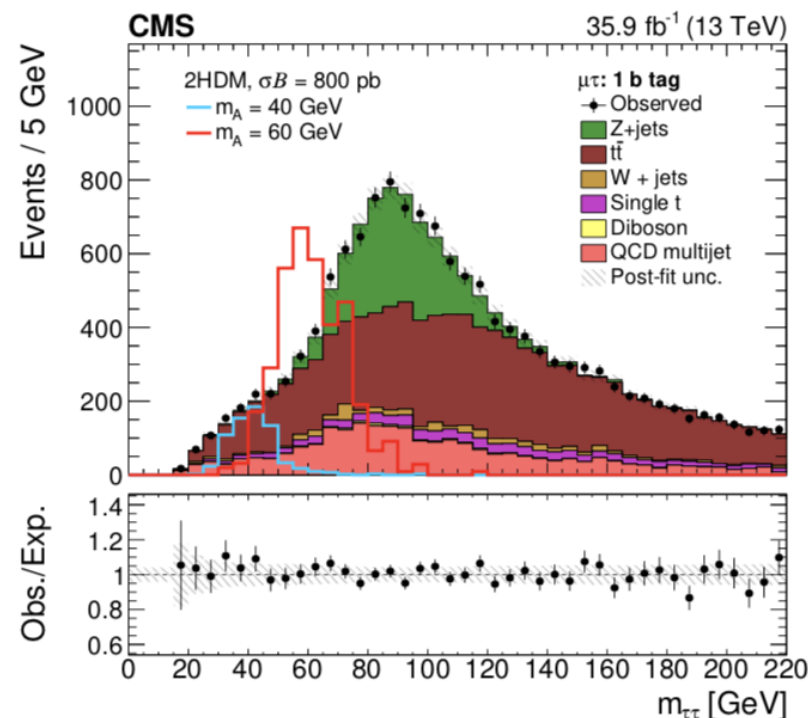
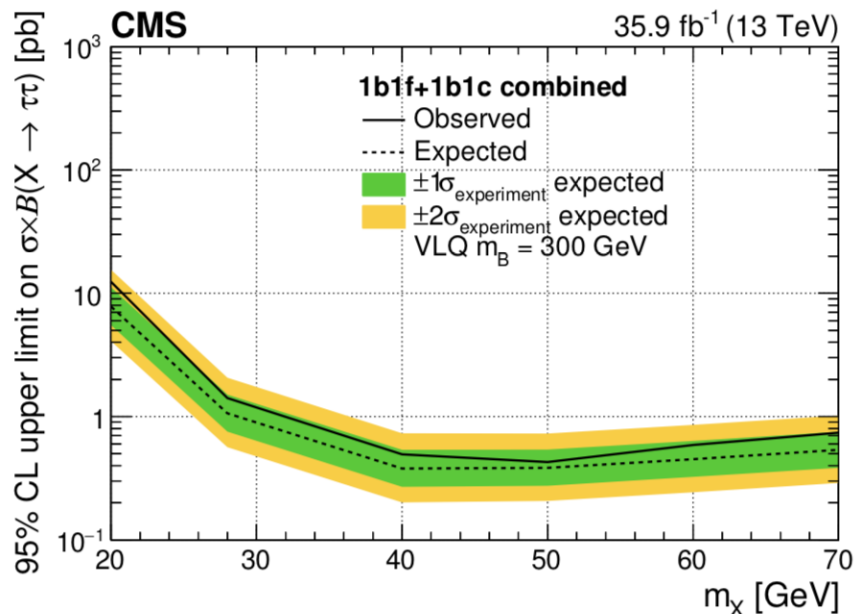
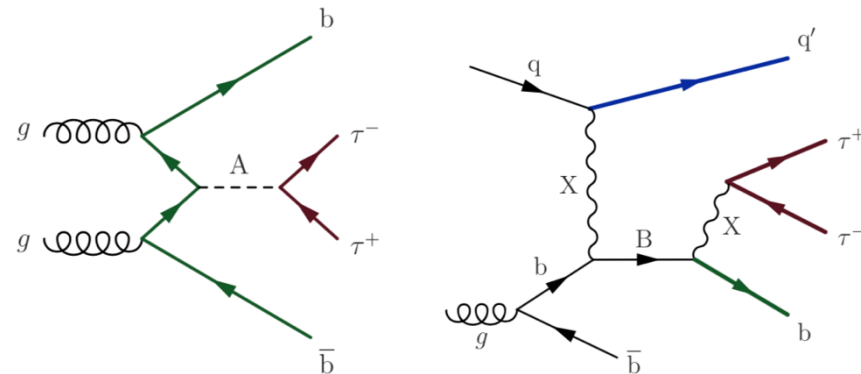

Low mass dilepton resonance

arXiv:2111.01299

- Search for low-mass dilepton resonances in Higgs decays in the four-lepton final state
- Decay through a pair of BSM particles, or one is a Z boson
- Set limits
 - model-independent Higgs BRs.
 - dark photon and ALP production

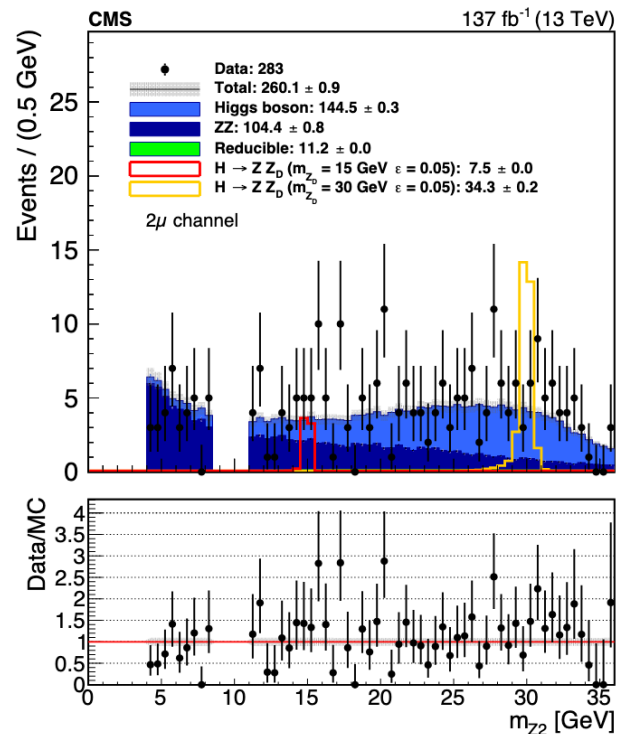
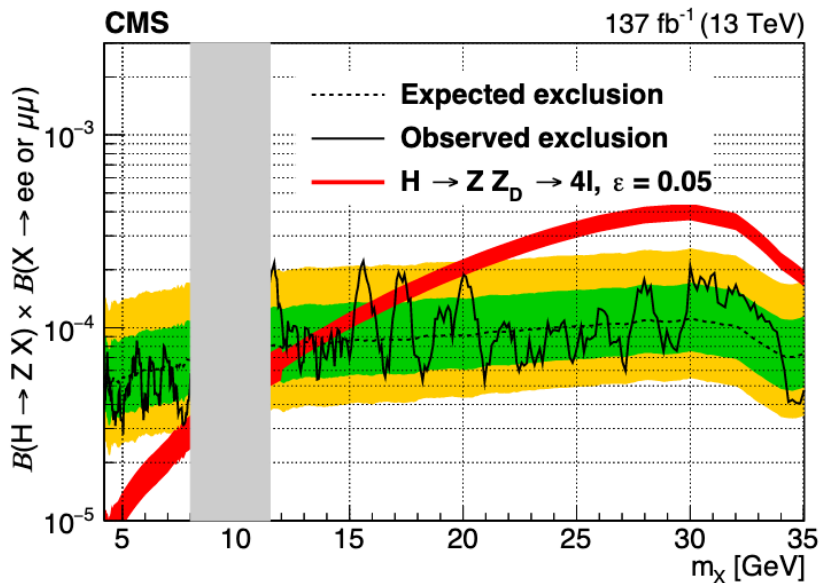
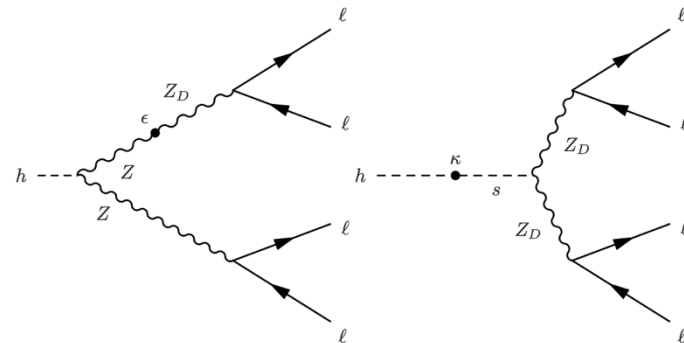

Heavy Higgs: $H \rightarrow t\bar{t}$

arXiv:1908.01115

- MSSM, low $\tan\beta$, $m(H) > 2 \times m(\text{top})$
- Search for $A/H \rightarrow t\bar{t}$
- Strong interference with SM $t\bar{t}$
- ℓ +jets and $\ell\bar{\ell}$ final states
- Kinematic reconstruction
 - $m(t\bar{t})$ and $\cos\theta^*$ (lepton angle in $t\bar{t}$ frame)

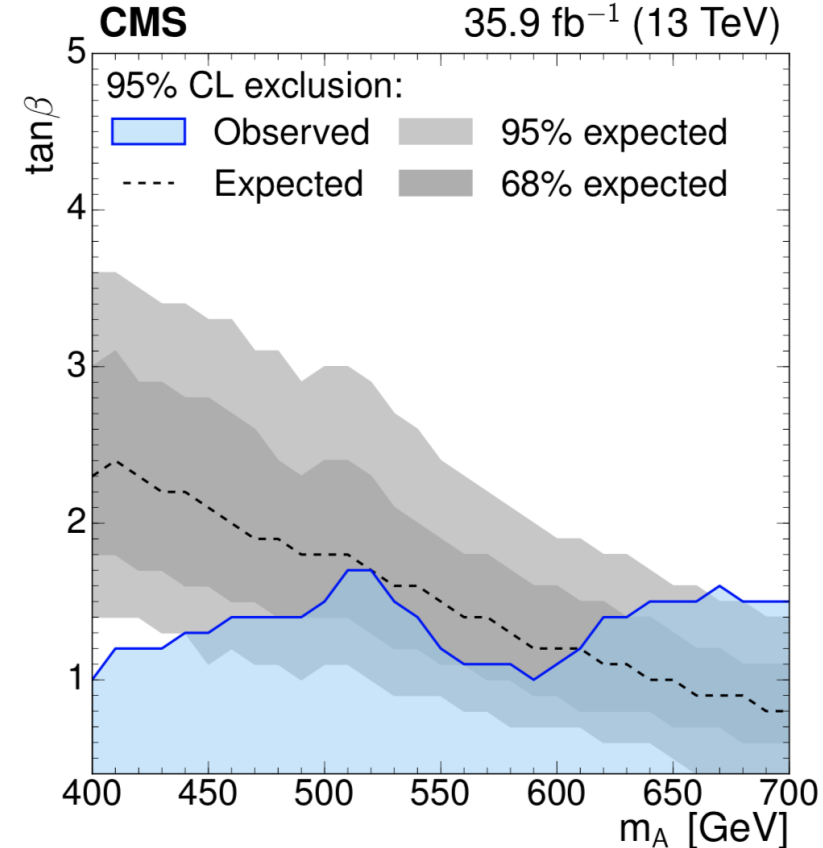
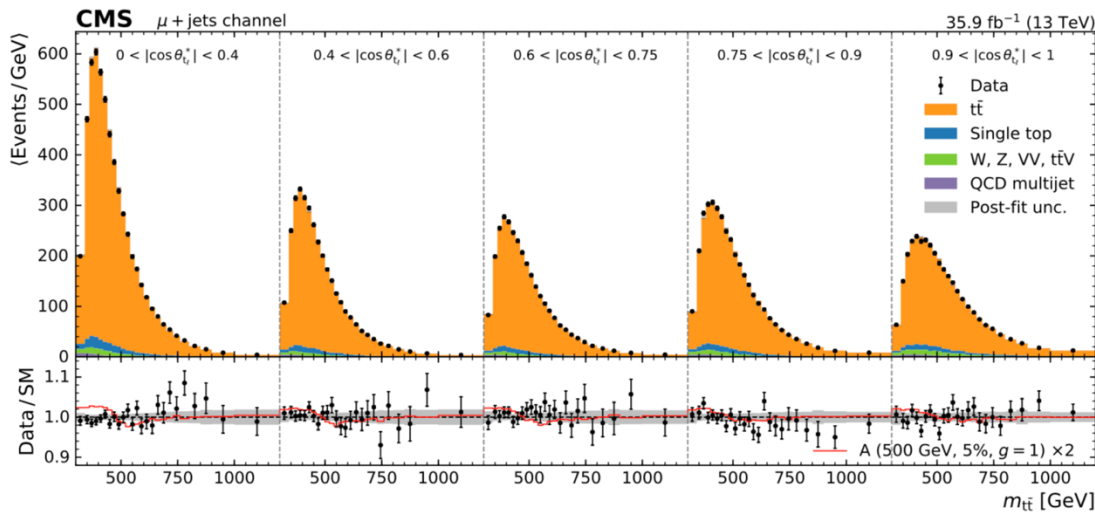
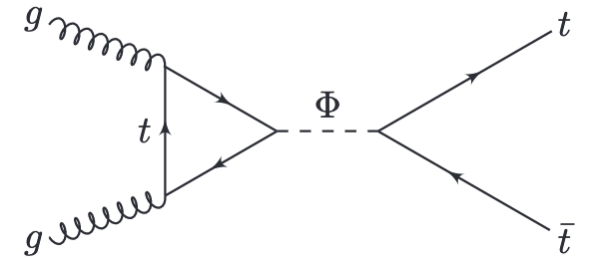

Higgs self-coupling

- Self-coupling measurements
- Improve measurements
- Include missing pieces:
 - H couplings to light fermions
 - HHVV (c_{2V}) and self-couplings

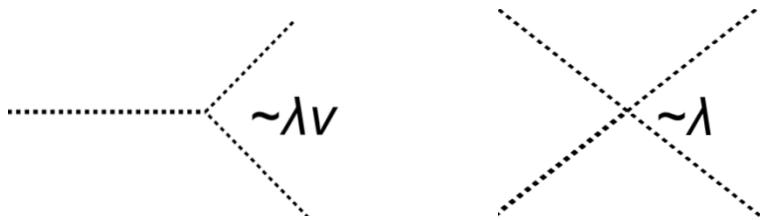

H trilinear coupling

$$\lambda = m_H^2/2v^2, \text{ where } v = \text{Higgs boson v.e.v}$$

Use coupling modifiers:

$$k_\lambda = \lambda/\lambda_{SM}; \quad k_{2v} = c_{2v}/c_{2v}(SM)$$

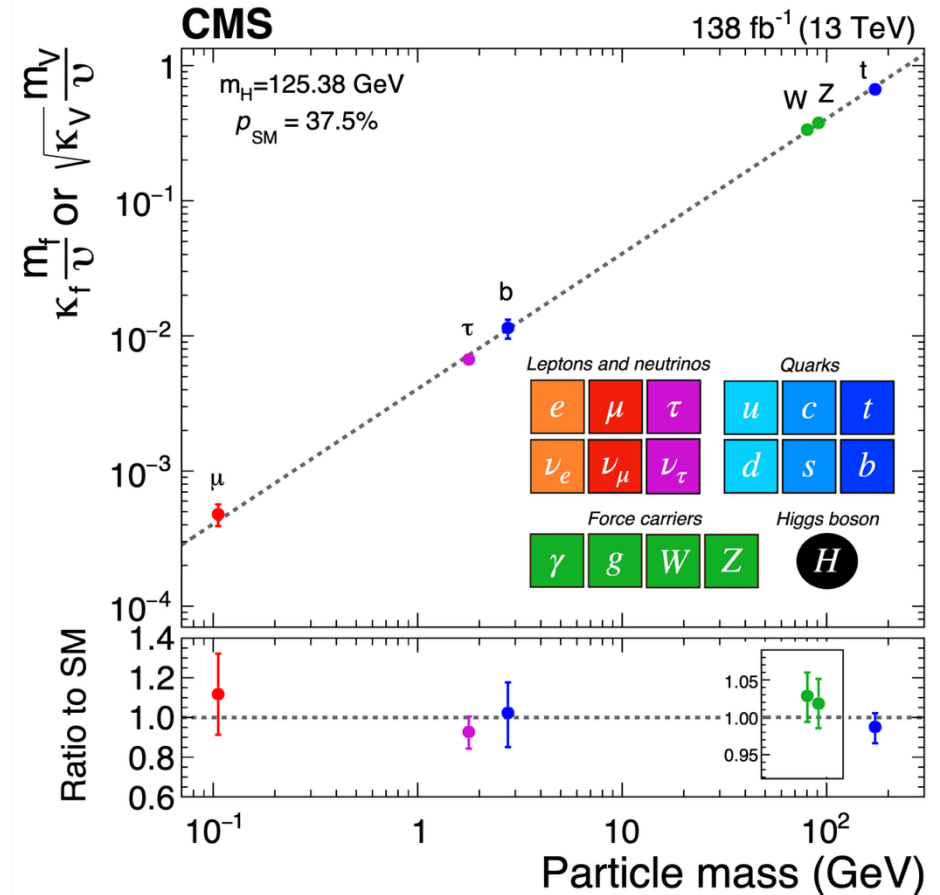

di-Higgs searches

- Self-coupling measurement
- Destructive interference in SM
 - Could be altered in BSM
 - If constructive, it could be large enhancement
- In SM, only $\sigma=31\text{fb}$ at 13 TeV
- Study different final states

	BR	Mass scale
$(X \rightarrow) hh \rightarrow$	$bbbb$	34%
	$bb\tau\tau$	7.3%
	$bbWW$	27%
	$bb\gamma\gamma$	0.26%
		High
		Low

$$V(h) = V_0 + \underbrace{\frac{1}{2}m_H^2 h^2}_{\text{Mass Term}} + \underbrace{\lambda_{hhh} v h^3}_{\text{HH production}} + \underbrace{\frac{1}{4}\lambda_{hhhh} h^4}_{\text{HHH production}}$$

non-resonant production

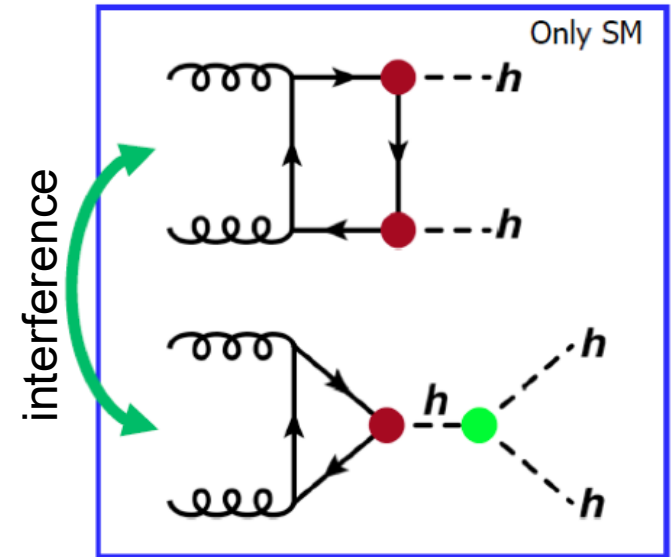

resonant production

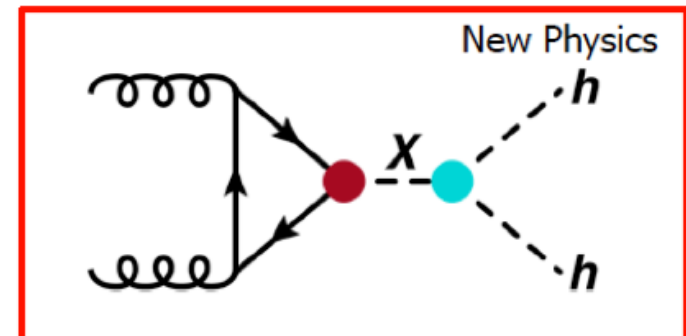

HH: non-resonant production

- Higgs pair production @13 TeV
 - ggF $\sigma=31$ fb
 - VBF $\sigma=1.7$ fb
- Test non-resonant BSM models with anomalous couplings

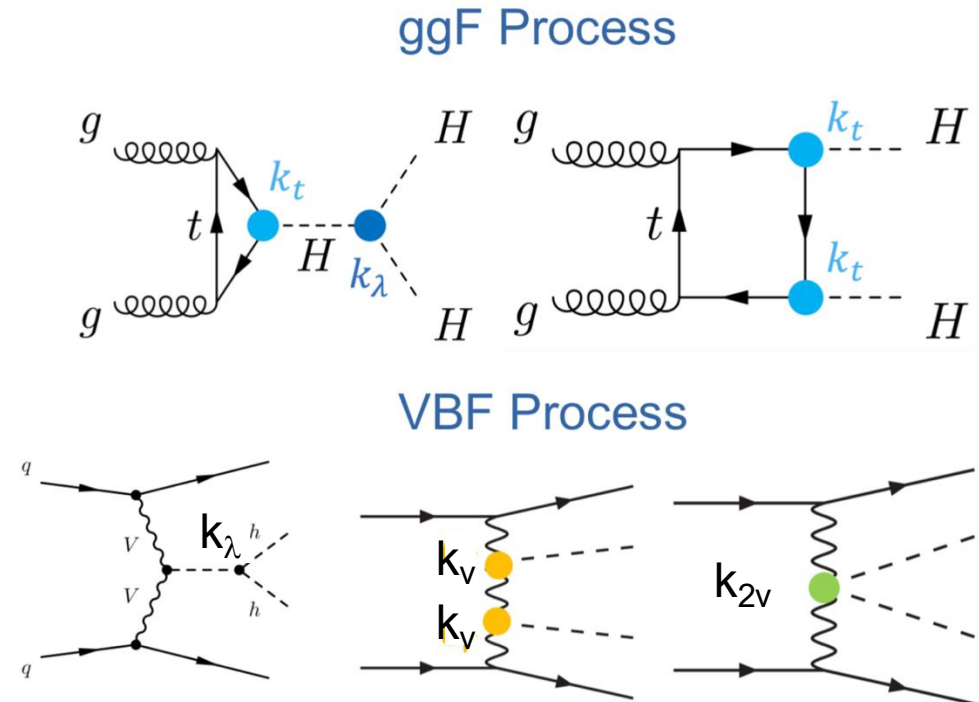
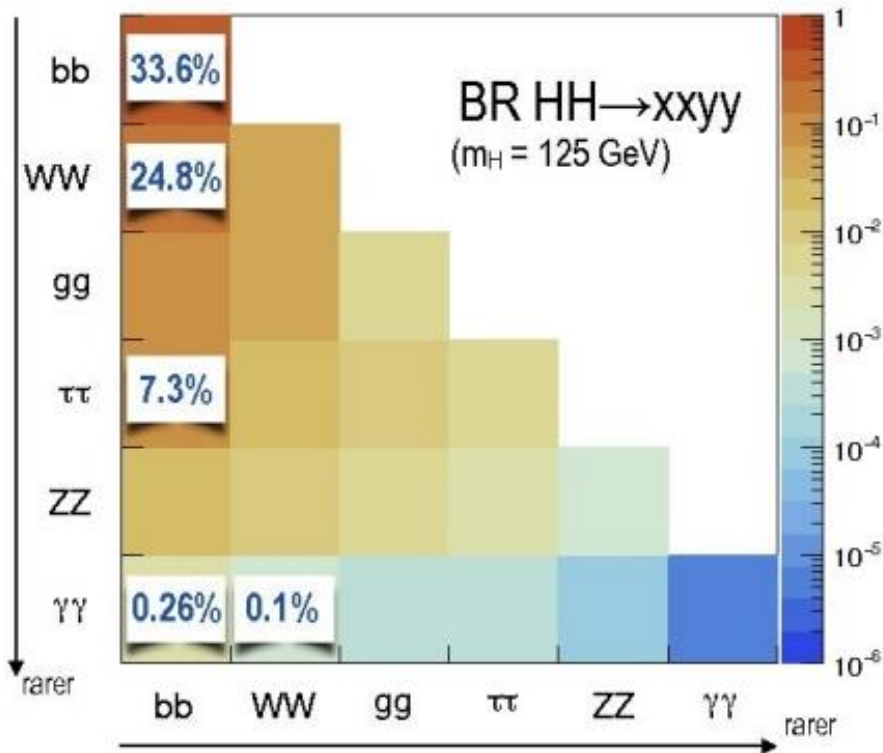

What is new in HH searches

CMS-HIG-20-010, CMS-B2G-21-001

- Results are better (x2-3) than 2016 results alone after scaling for luminosity

Extensive use of ML tools

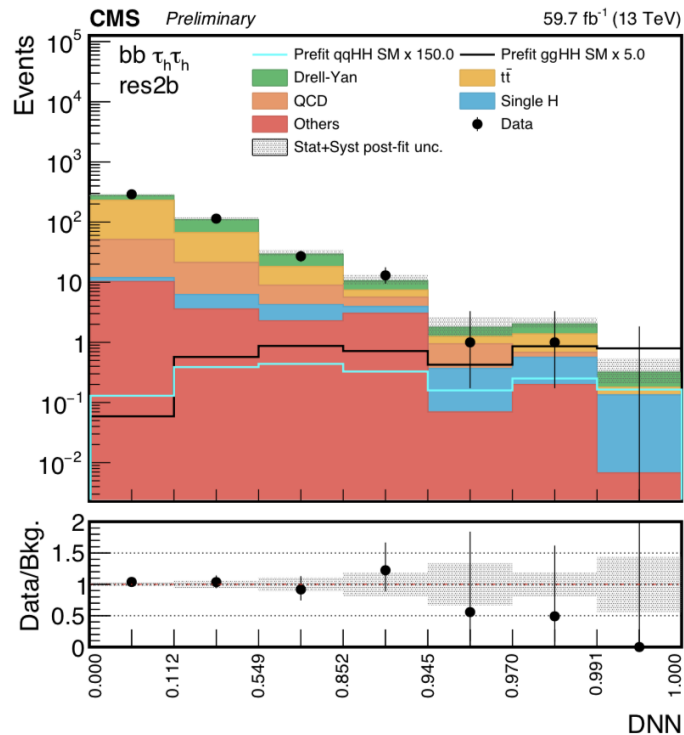

DNN score for resolved ggHH(bb $\tau\tau$) category

Boosted topologies

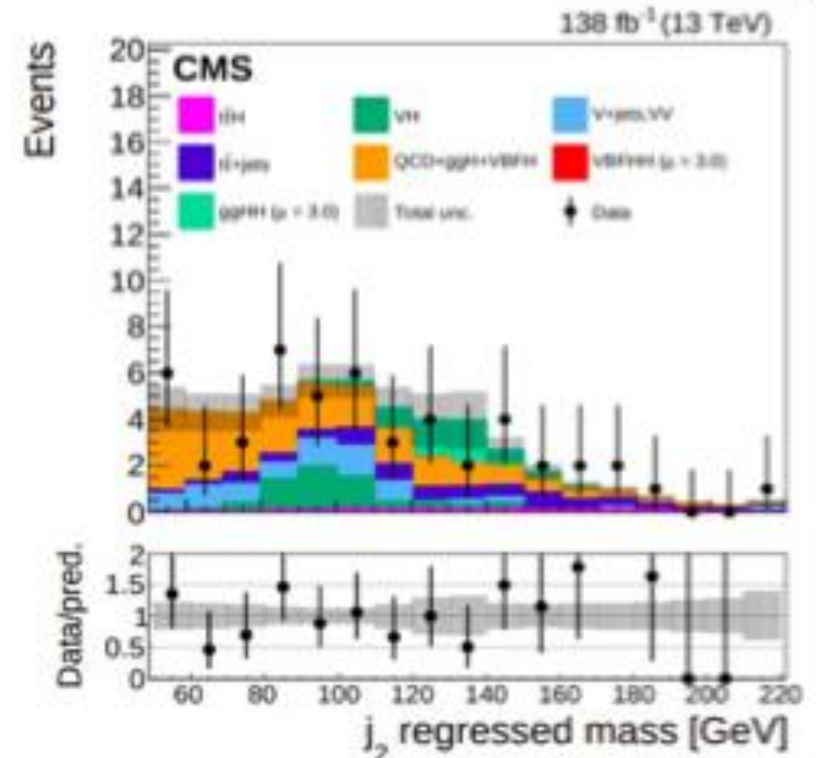

Regressed mass of one AK8 jet in a ggHH(4b) boosted category

HH combination

Nature 607(2022)60, CMS-HIG-PAS-20-011

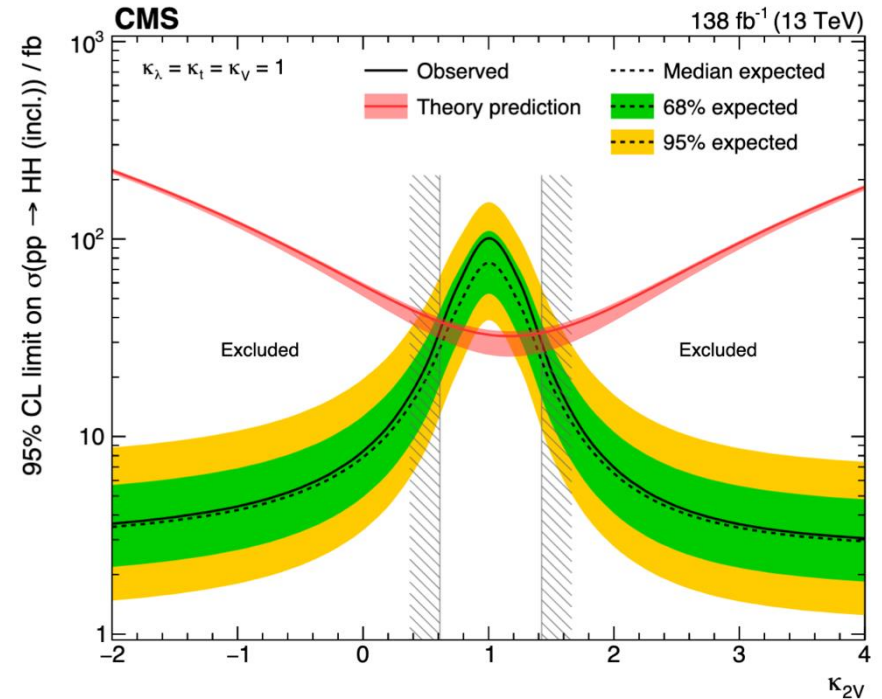
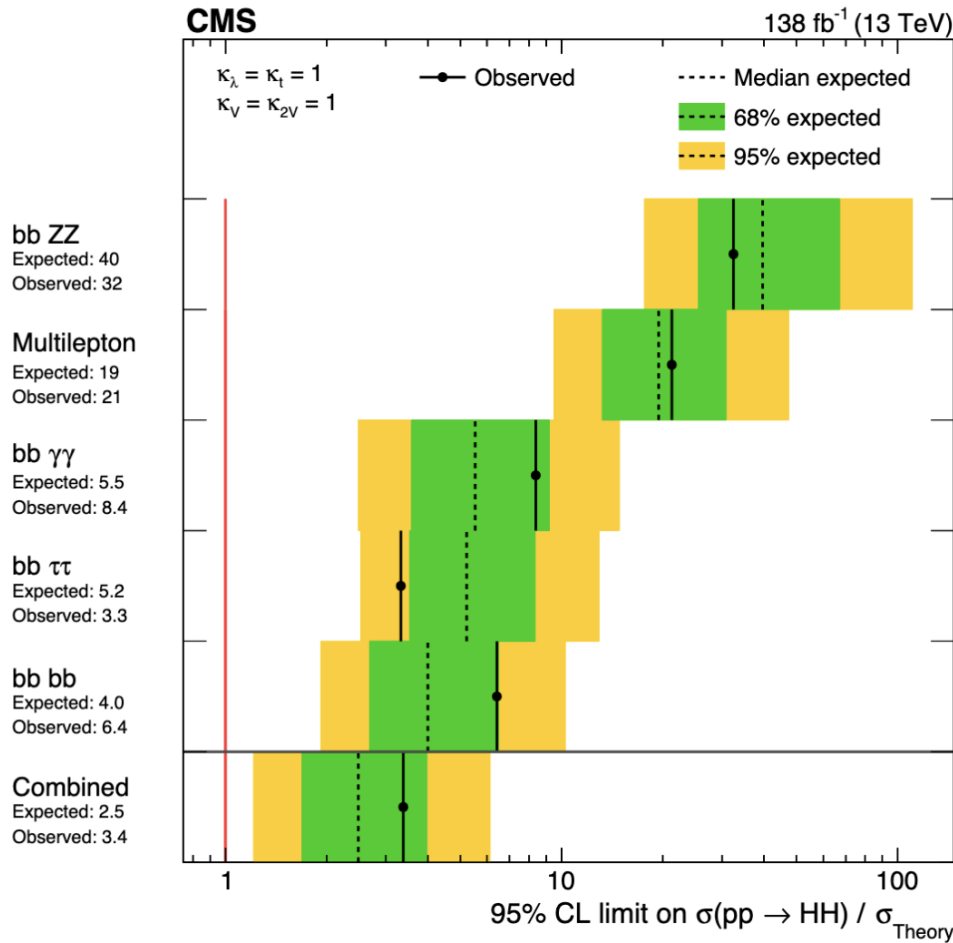

- $\kappa_\lambda \in [-1.4, 7.0]$ @95%CL
- $\kappa_{2V} \in [0.6, 1.4]$ @95%CL

$$\mu_{HH} \leq 3.5(2.5)$$

Self-coupling: H and HH

arXiv:2407.13554

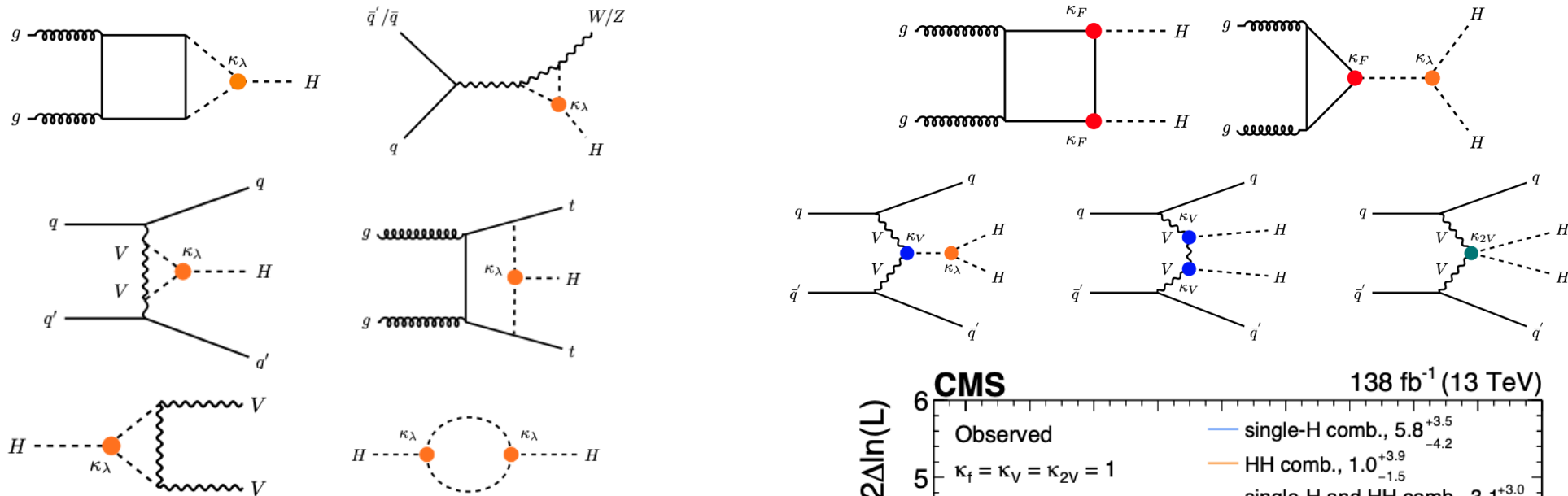

- Set constraints on H self-coupling
- Use H and HH results:
 - HHVV coupling (κ_{2V}) affects VBF HH mechanism
 - H: Use NLO EWK corrections

$$\Rightarrow \kappa_\lambda \in [-1.2, 7.5] \text{ @95\%CL}$$

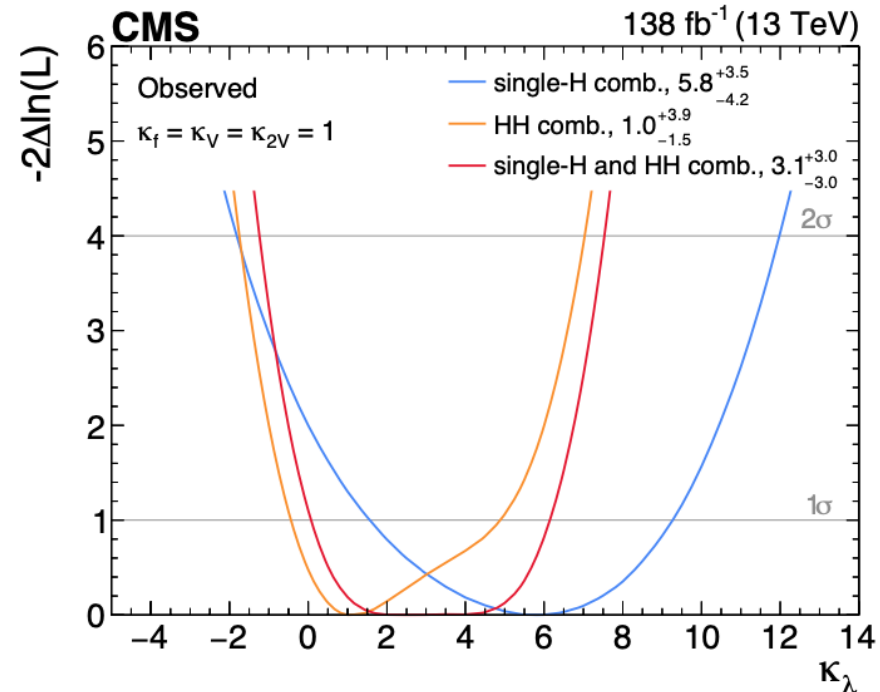

Double Higgs production

PRL 122(2018)121803

- Study different final states
- Not yet at the SM sensitivity

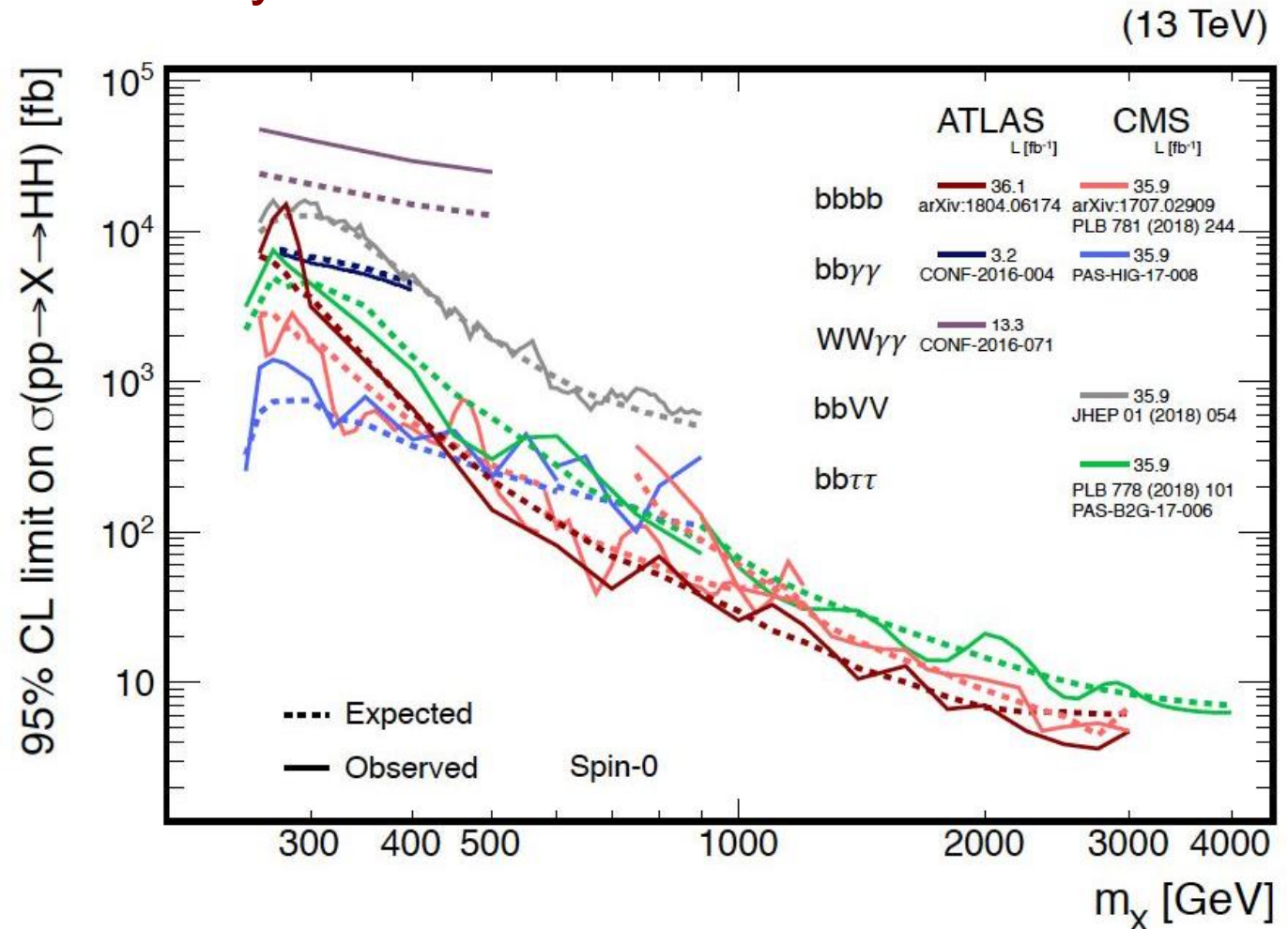

Double Higgs production

arXiv:2311.15956

- Study different final states
- Not yet at the SM sensitivity

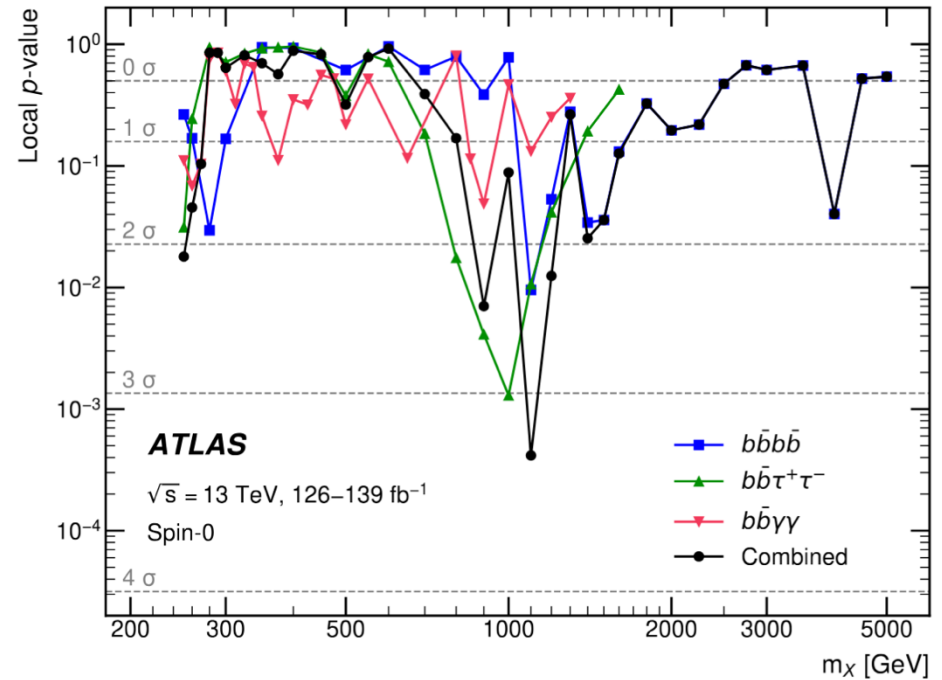
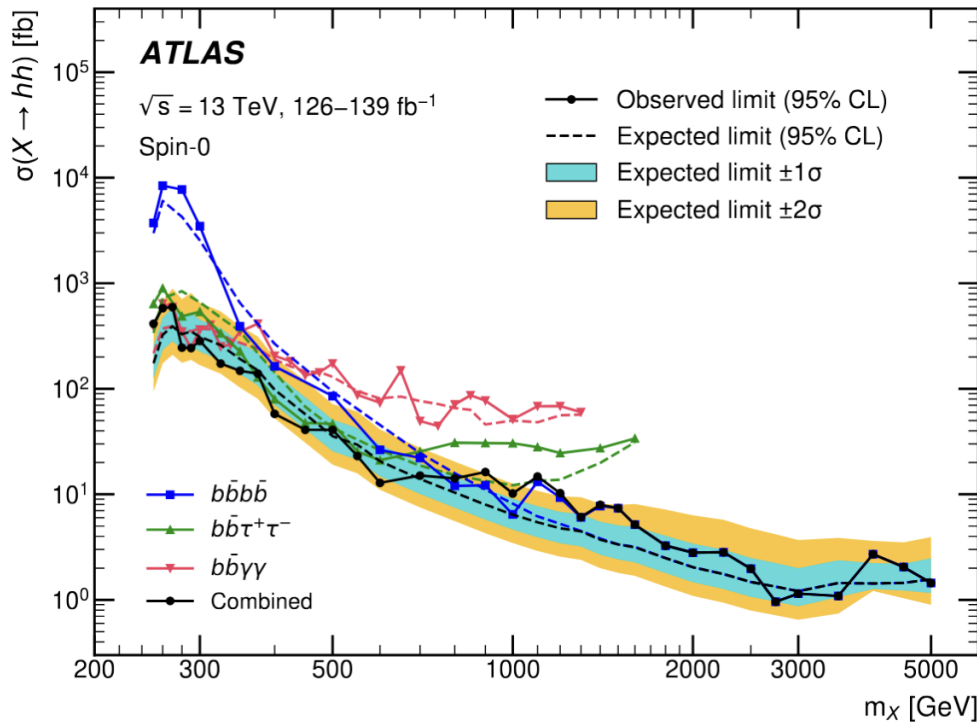

LFV in Higgs decays

arXiv:1911.10267, arXiv:2105.03007

- Some BSM models allow for LFV Higgs decays
- Search for $H \rightarrow e\tau, e\mu, \mu\tau$ final states
- Categories: N_{jet} , lepton kinematics
 - N_{jet} to target ggH and VBF production
- Main background from DY, $t\bar{t}$, WW

	Observed (expected) upper limits (%)	Best fit branching fractions (%)	Yukawa coupling constraints
$H \rightarrow \mu\tau$	<0.15 (0.15)	0.00 ± 0.07	< 1.11 (1.10) $\times 10^{-3}$
$H \rightarrow e\tau$	<0.22 (0.16)	0.08 ± 0.08	< 1.35 (1.14) $\times 10^{-3}$

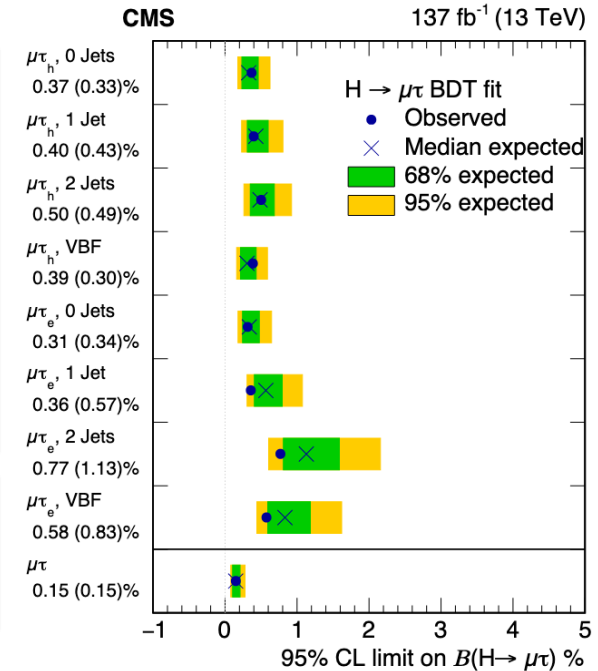
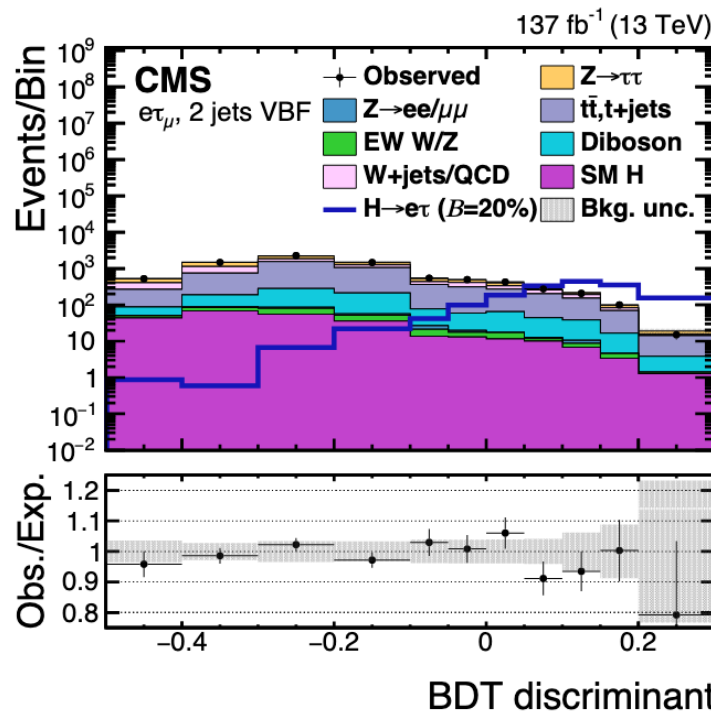
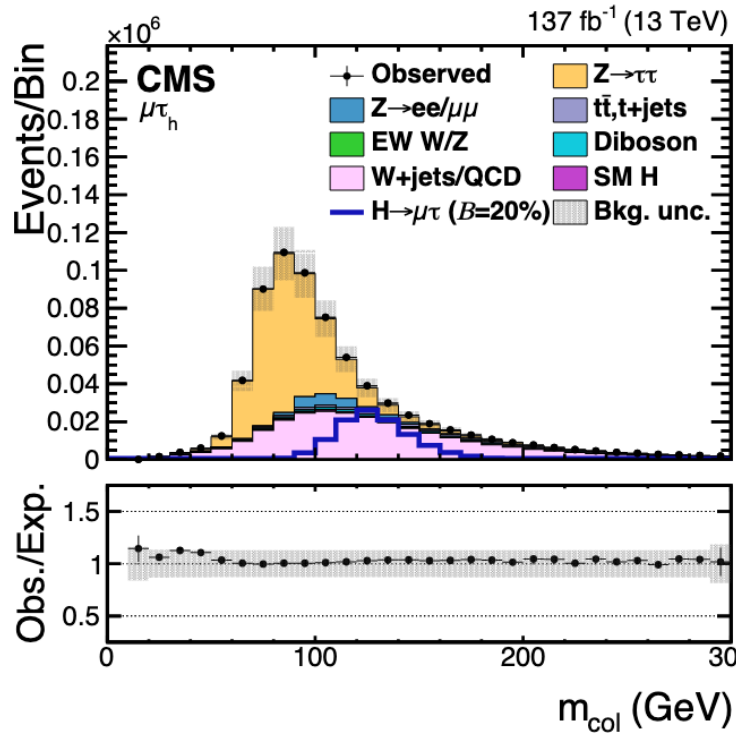

DM at the LHC

- CMS/ATLAS experiments **not** designed for DM searches

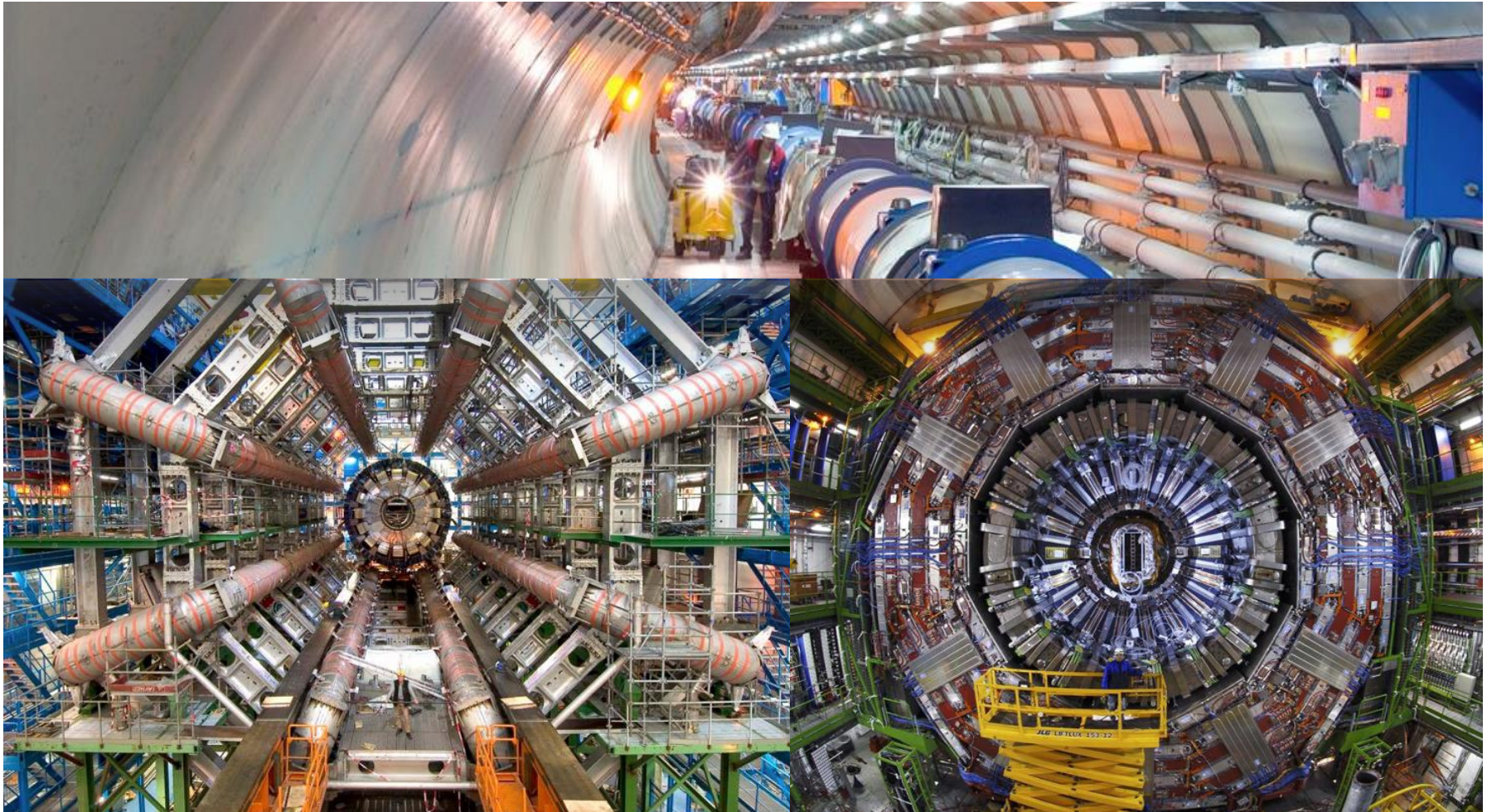

DM searches at LHC

How do we find DM at the LHC?

- DM production gives MET signature

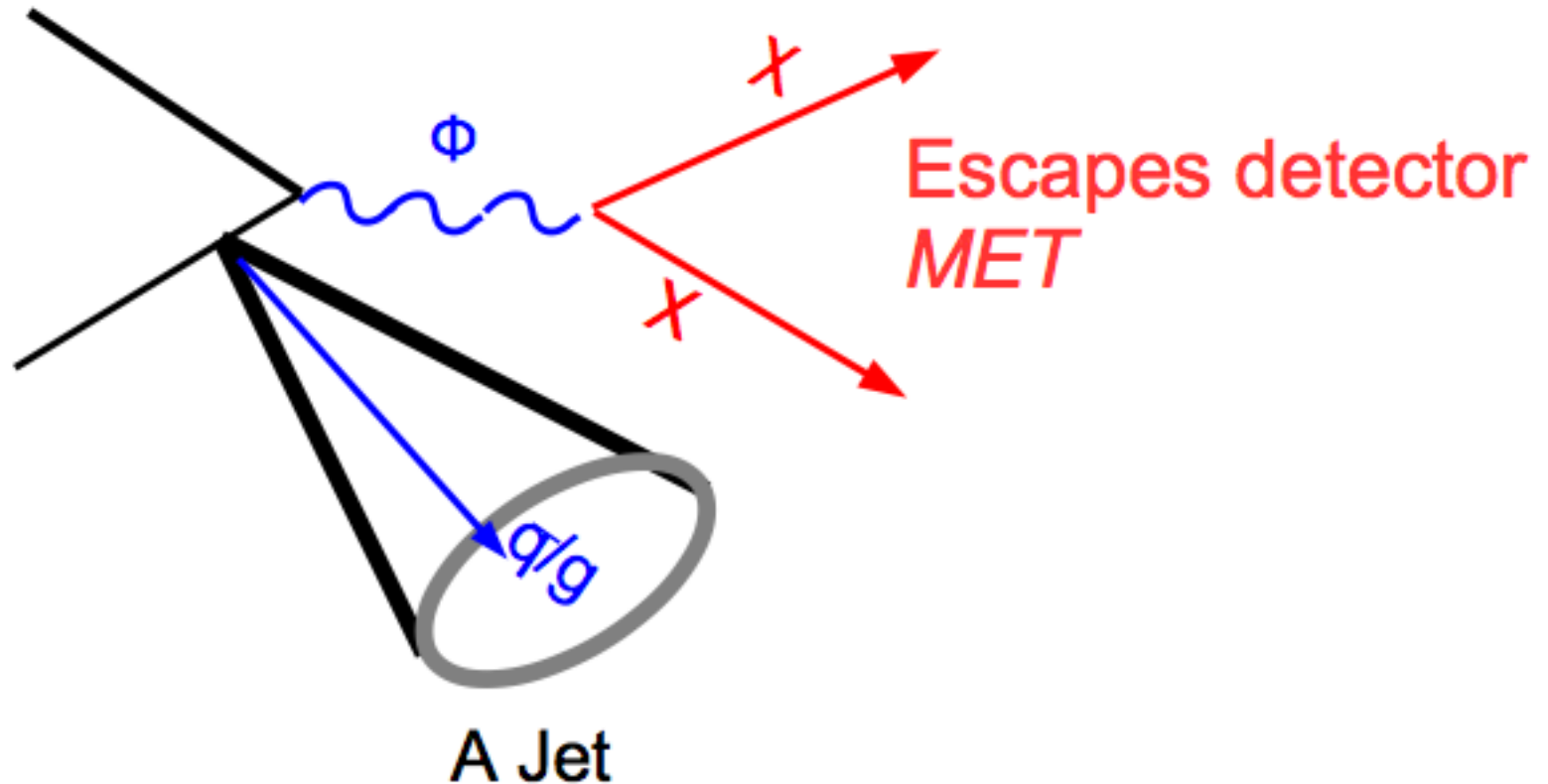

DM searches: backgrounds

What are the backgrounds?

- $Z \rightarrow \nu\nu$

–very similar to signal

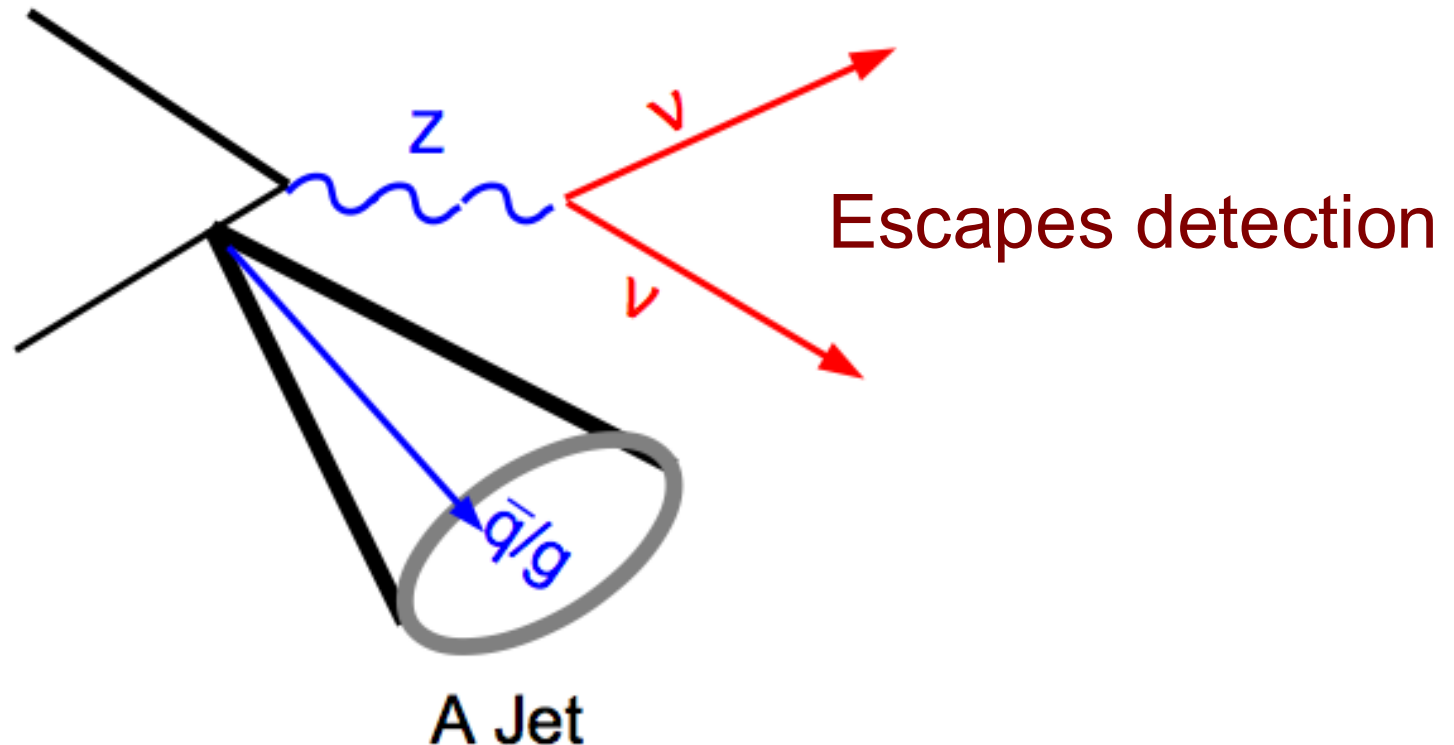

DM searches: backgrounds (cont.)

How to discriminate signal against the background?

- Look for high MET:

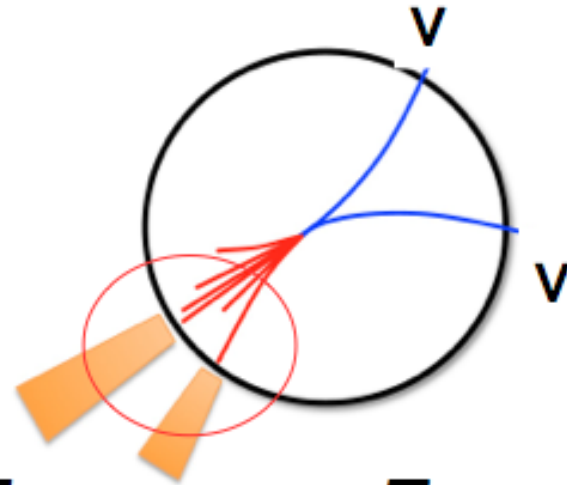

Study hadronic recoil

$$MET = -\sum_{\text{All particles}} p_T$$

$$MET(Z \rightarrow \nu\nu) = -Z \text{ recoil} + p_T(\nu\nu)$$

$$MET(Z \rightarrow \nu\nu) = -Z p_T$$

DM searches: backgrounds (cont.)

How to discriminate signal against the background?

- Can fit the shape and look for signal

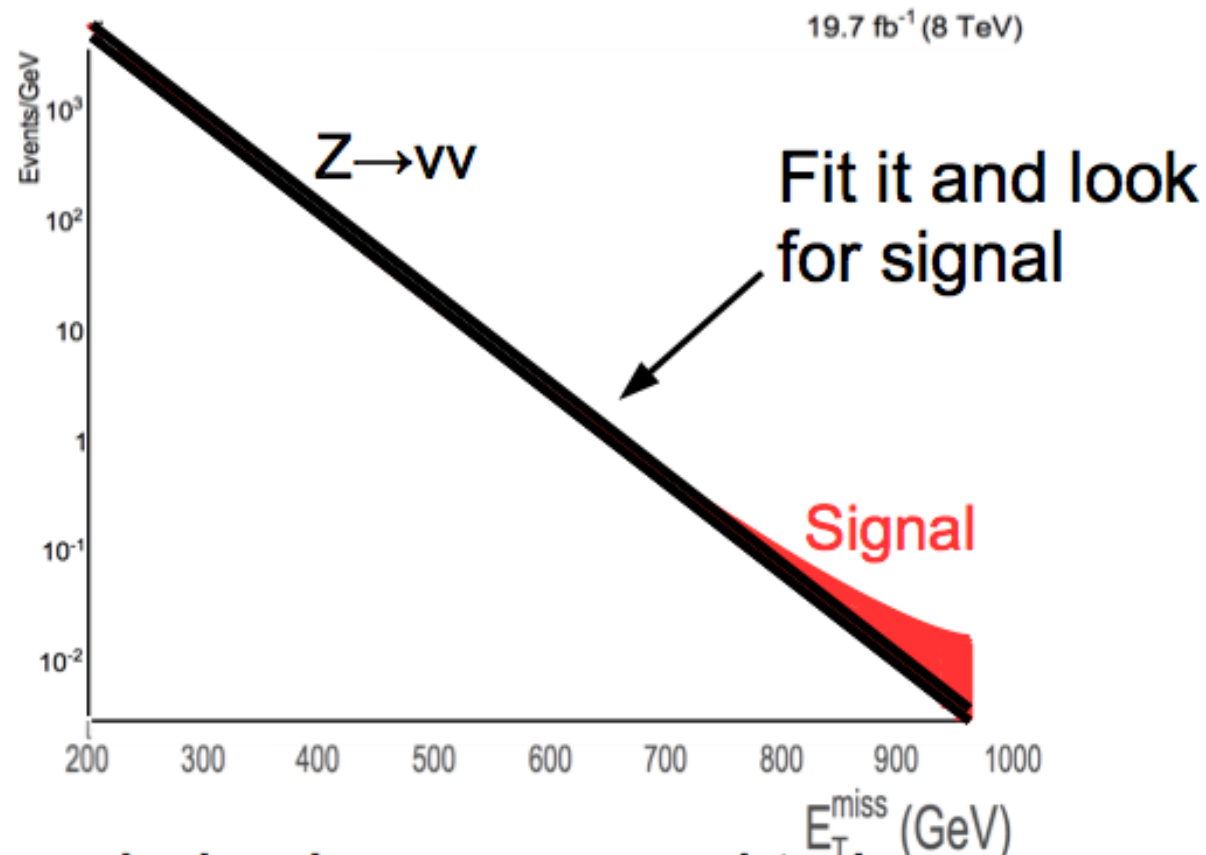

DM searches with Higgs bosons

- Higgs as portal to Dark sector
 - New massive particle mediates the Higgs-DM interaction
- H(125) may mix with new dark mediators
 - DM particles could get mass through Higgs mechanism
- Study scenarios where Higgs is involved

Mono-Higgs

- Generic search: $pp \rightarrow H + \text{MET}$
- ISR suppressed due to small coupling to H
- Signature: Higgs+MET \Rightarrow H used as a tag
- Final states (WW, ZZ, bb, $\tau\tau$, $\gamma\gamma$)

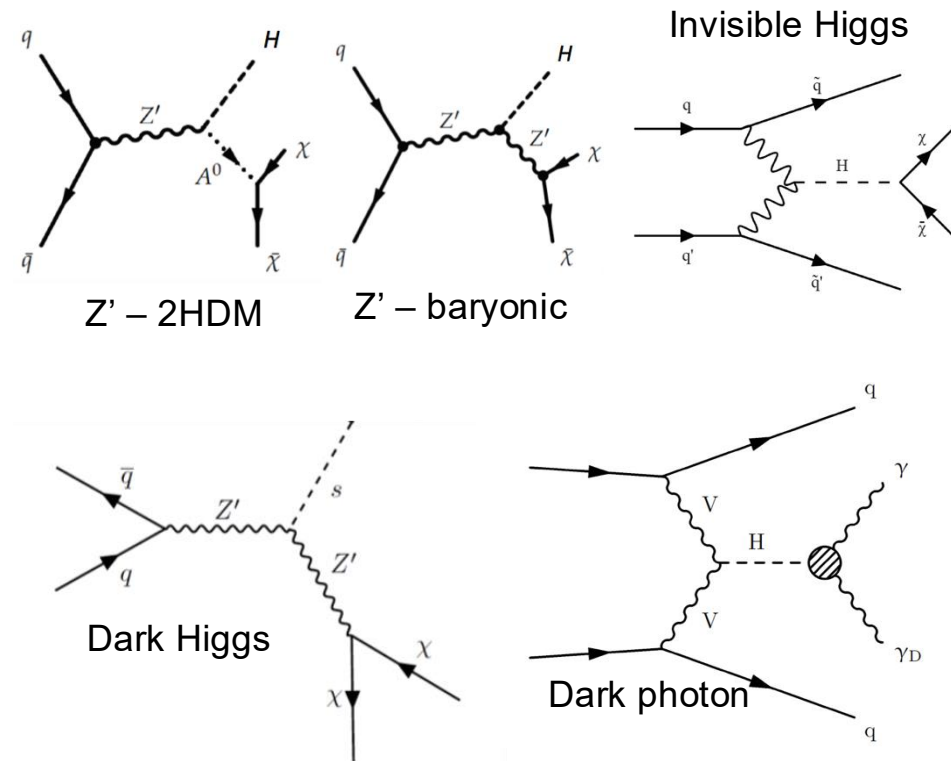

DM+jet/V

arXiv:2107.13021

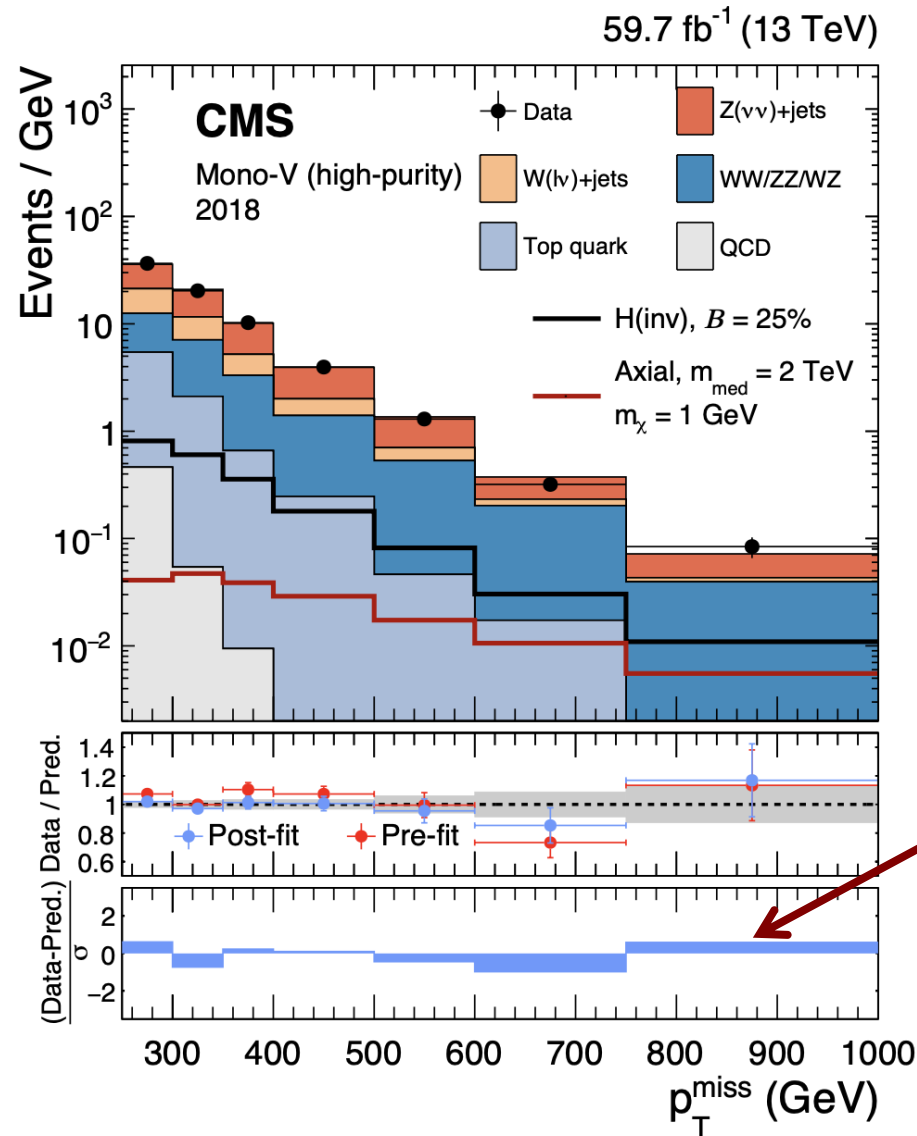

DM search in mono-jet/V

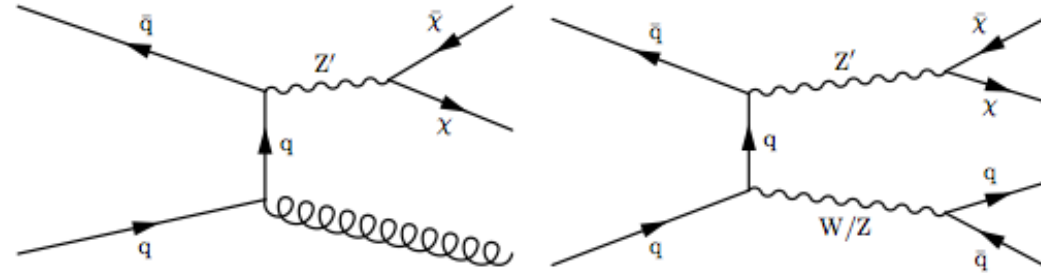

Need good control of systematics

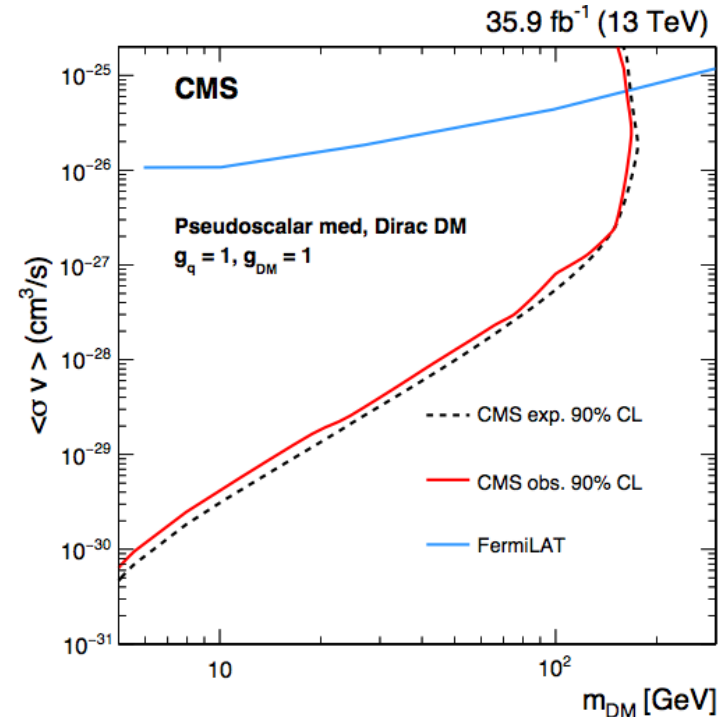

VBF: H(invisible)

arXiv:2201.11585, arXiv:2201.11585

- In the SM, $B(H \rightarrow \text{invisible})$ only 0.1%
 - Any significant deviation would indicate BSM
 - Signature: Large MET, $\Delta\phi(jj)$, veto ℓ/b -jets
 - C&C and shape fit of $m(jj)$
 - Main bkg: V+jets (95%)
 - Tag with forward jets+MET
- Set limits: $B(H \rightarrow \text{inv.}) < 0.18$ (0.10) @95%CL

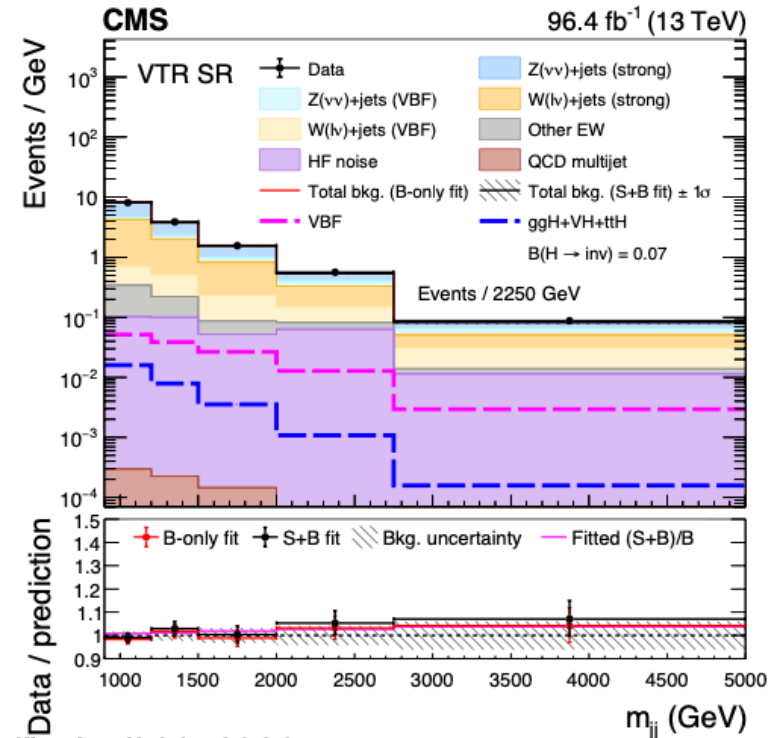
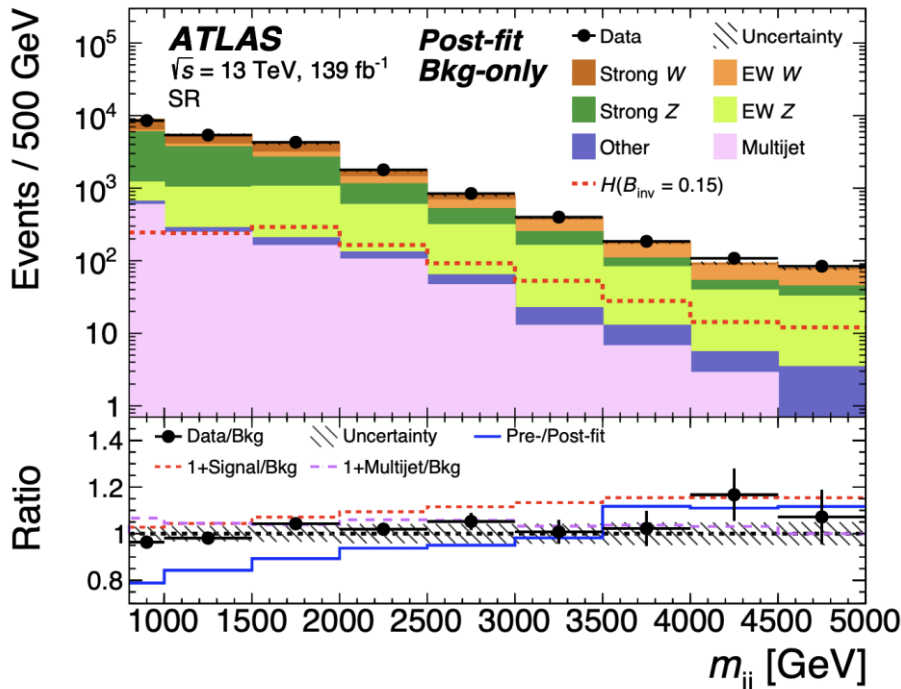
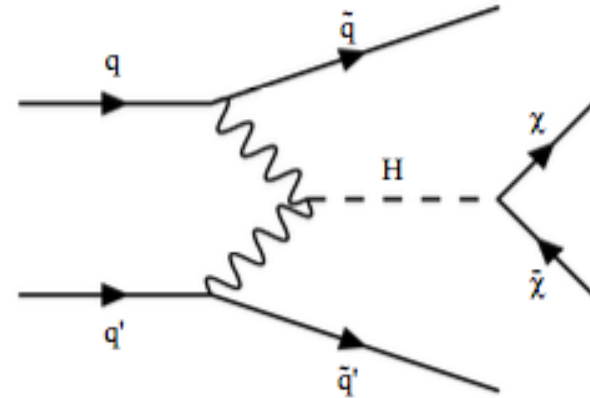

DM+Higgs

arXiv:1806.04771

- DM search with $H(\rightarrow\tau\tau,\gamma\gamma)$
- Model dependent search
 - Z' 2HDM Model and barionic Z'

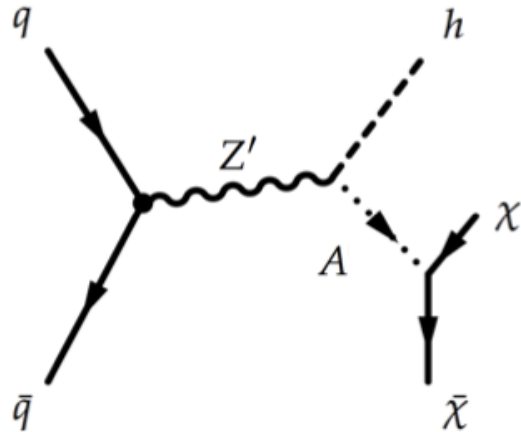

- No significant excess
- Set limits

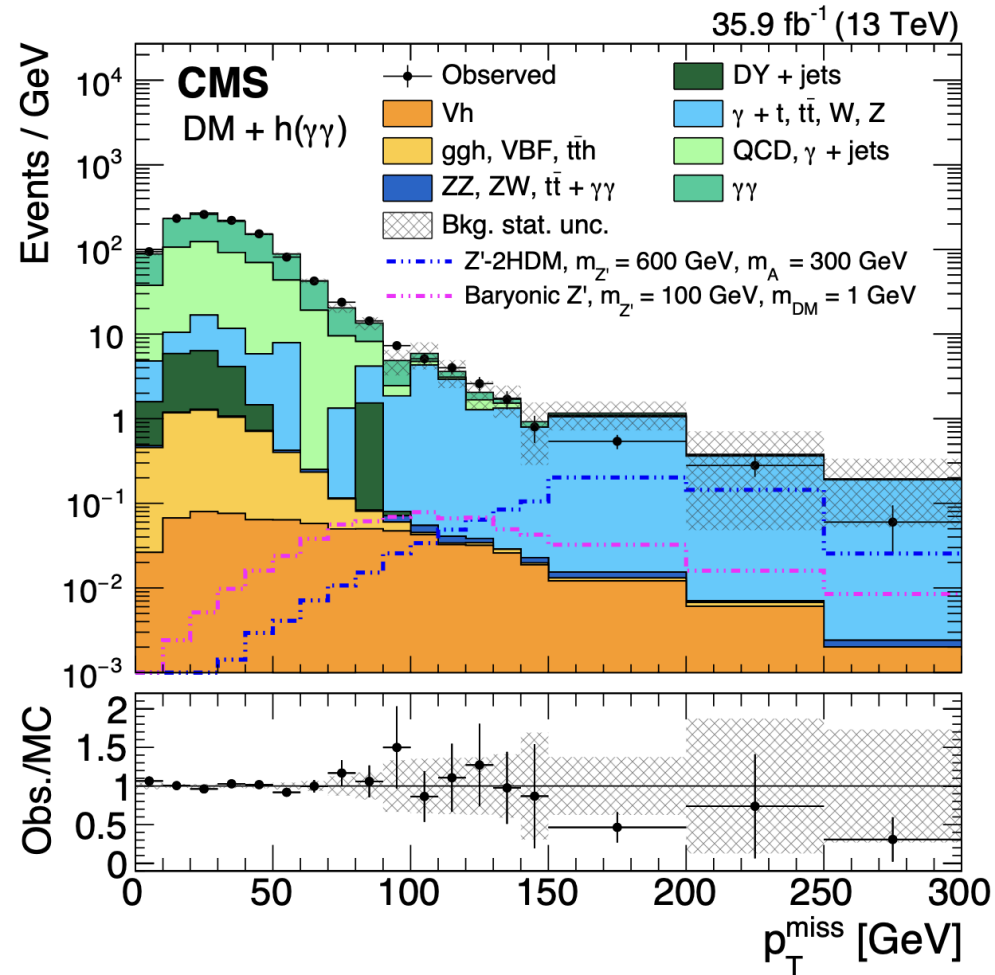

DM searches with Higgs bosons

- H(125) may mix with new dark mediators
- Signature: Higgs+MET \Rightarrow H used as a tag
- Final states:
 - $H \rightarrow bb \sim 58\%$, large bkg
 - $H \rightarrow WW \sim 21\%$, moderate bkg
 - $H \rightarrow \tau\tau \sim 6\%$, lower bkg
 - $H \rightarrow \gamma\gamma \sim 0.2\%$, clean final state

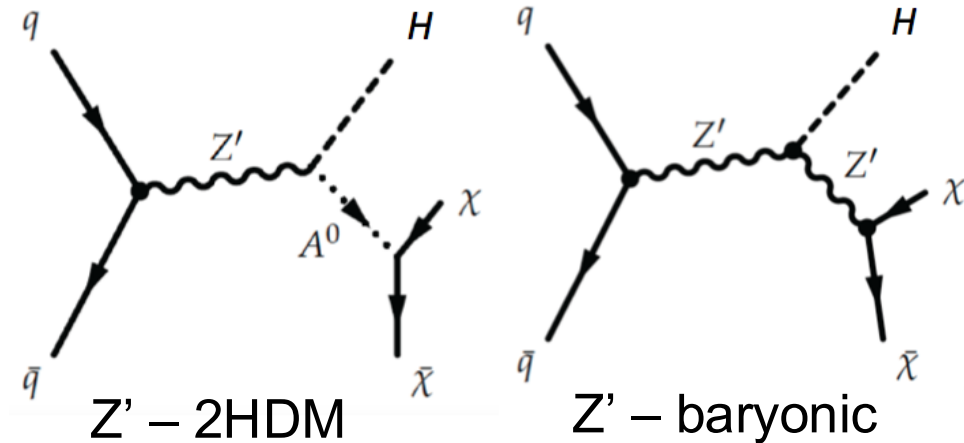

Higgs + Dark Matter

arXiv:1908.01713

- Generic search: $pp \rightarrow H + \text{MET}$
 - ISR suppressed due to small coupling to H
 - In the context of simplified models
- DM search with $H(\rightarrow bb, \gamma\gamma, ZZ, WW, \tau\tau)$
- Signal events at large MET

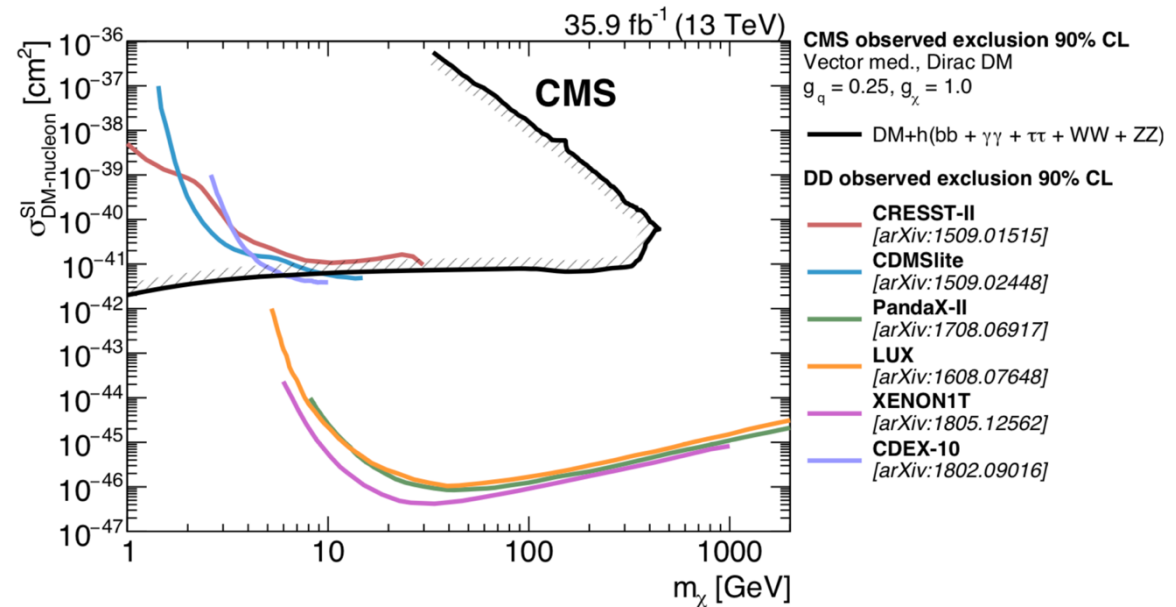
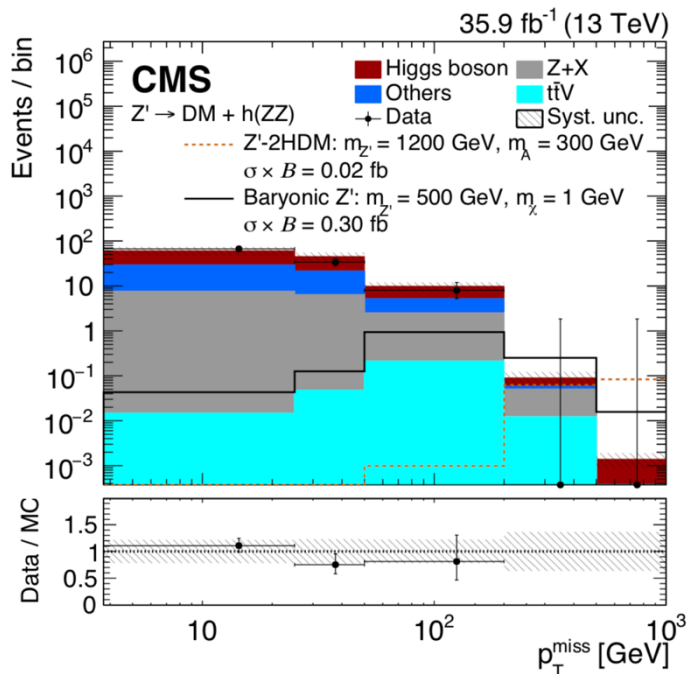
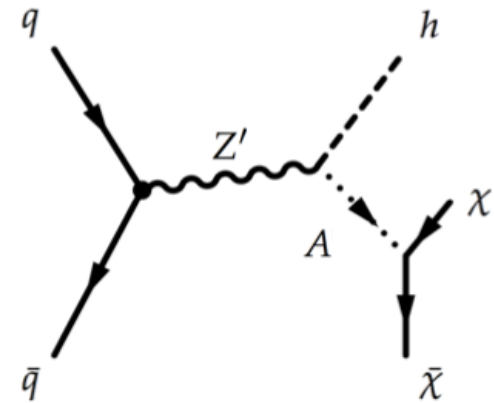

Dark Higgs & Dark photon

arXiv:2310.12229, arXiv:1908.02699, arXiv:2009.14009, arXiv:2405.13778

Dark Higgs

- DM particle acquire mass through interaction with a dark Higgs (s)
- WW decay dominates for $m_s > 160\text{GeV}$
 - leptonic final state ($2\ell 2\nu$, $2\ell 2q$)
- **Observable:** $m_T(\ell, \text{MET})$

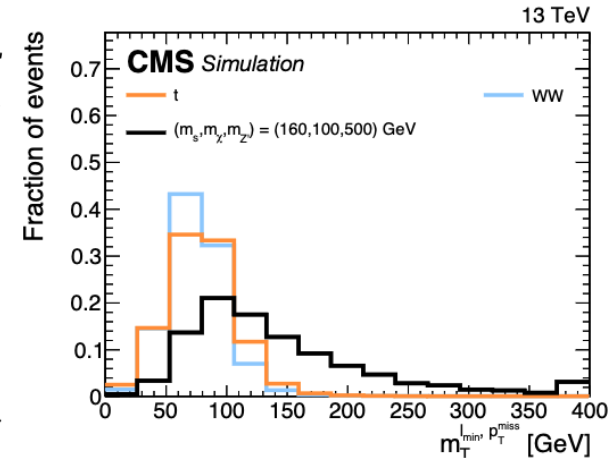
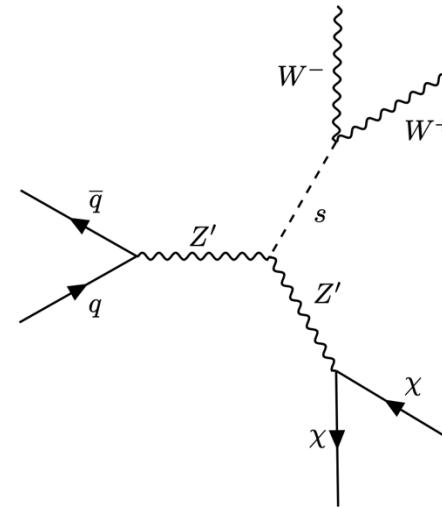

Dark photon

- Search in ZH & VBF events

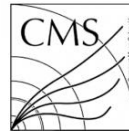
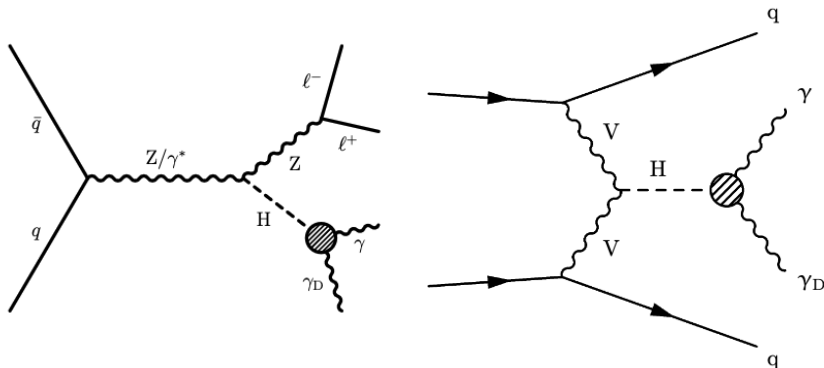

CMS Experiment at LHC, CERN
Data recorded: Mon Sep 26 13:12:31 2016 PDT
Run/Event: 281693 / 947253769
Lumi section: 501

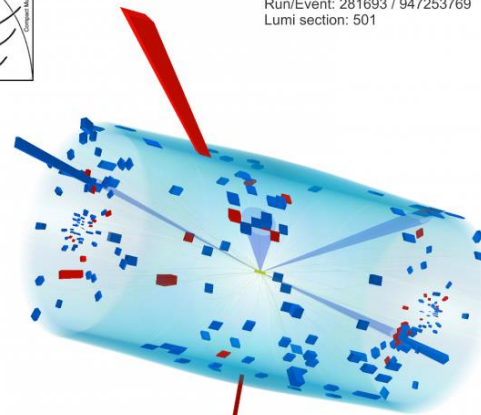

discriminating variable, m_T ,

$$\sqrt{2 \cdot p_T^\gamma \cancel{E}_T \cdot (1 - \cos \Delta\phi(\gamma, \cancel{E}_T))}$$

M. Gallinaro - "The Higgs boson and beyond" - April 20, 2026

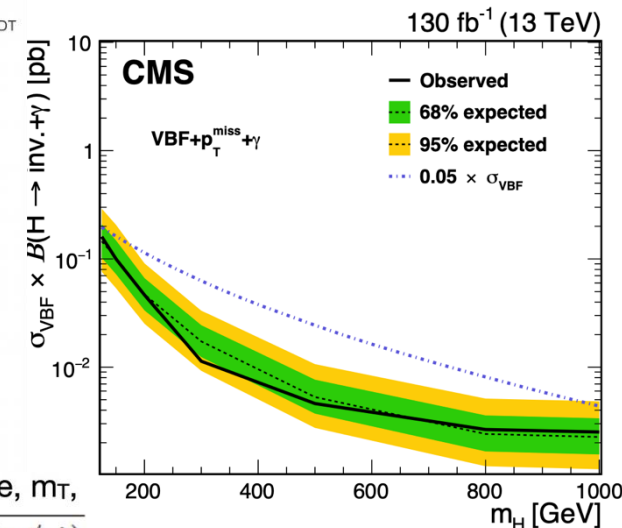

DM: Higgs invisible decays

arXiv:2201.11585, arXiv:2303.01214

- In the SM, $BR(H \rightarrow \text{inv})$ is $\sim 0.1\%$
 - Search for Higgs invisible decays in VBF and associated production
 - Select large MET and 2-jet events with large $\Delta\eta(\text{jj})$
 - Fit to dijet invariant mass distributions
 - Combination of ggH , $V(\text{jj})H$, and $Z(\ell)H$, $t\bar{t}H$ production modes
 - Set limits on DM models
 - Upper limits: $0.15(0.08\text{exp})@95\%CL$
 - Limits interpreted in the context of Higgs portal models
- \Rightarrow Competitive limits for low-mass DM candidates

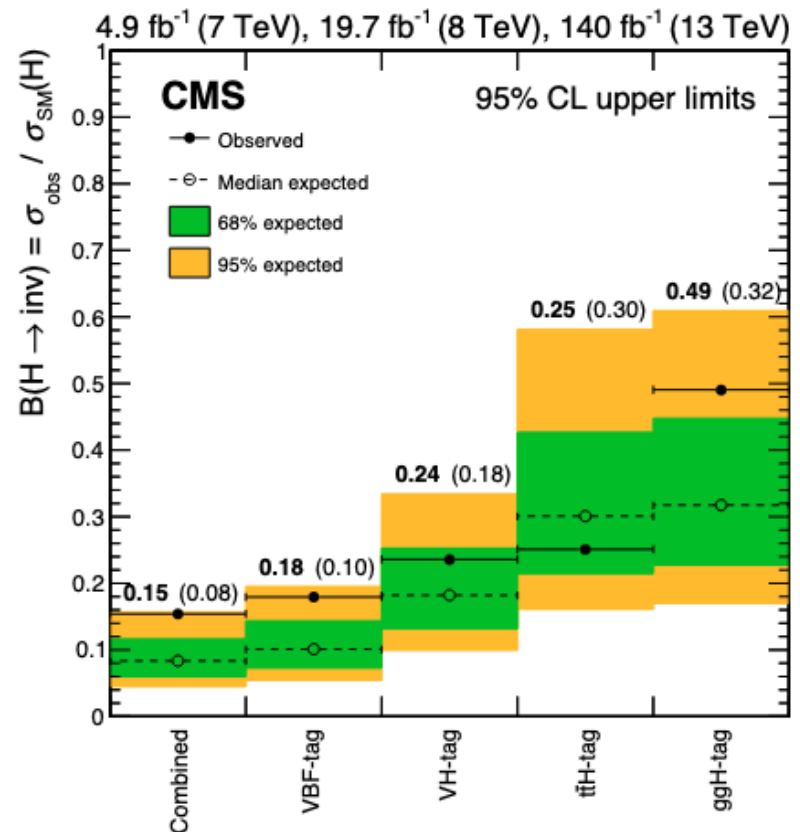
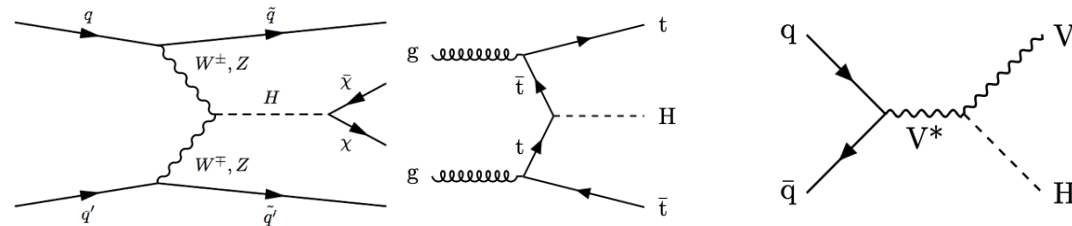

Experimental results

arXiv:2201.11585

- Limits for given couplings between SM and DM interaction
- **Competitive limits at low masses wrt other experiments**

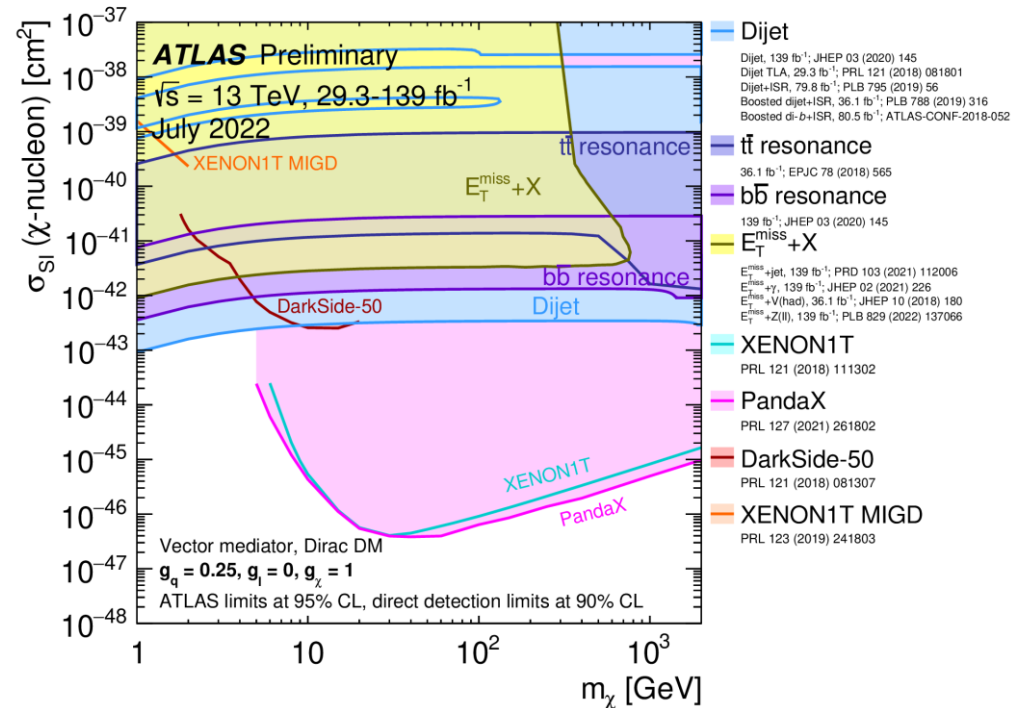
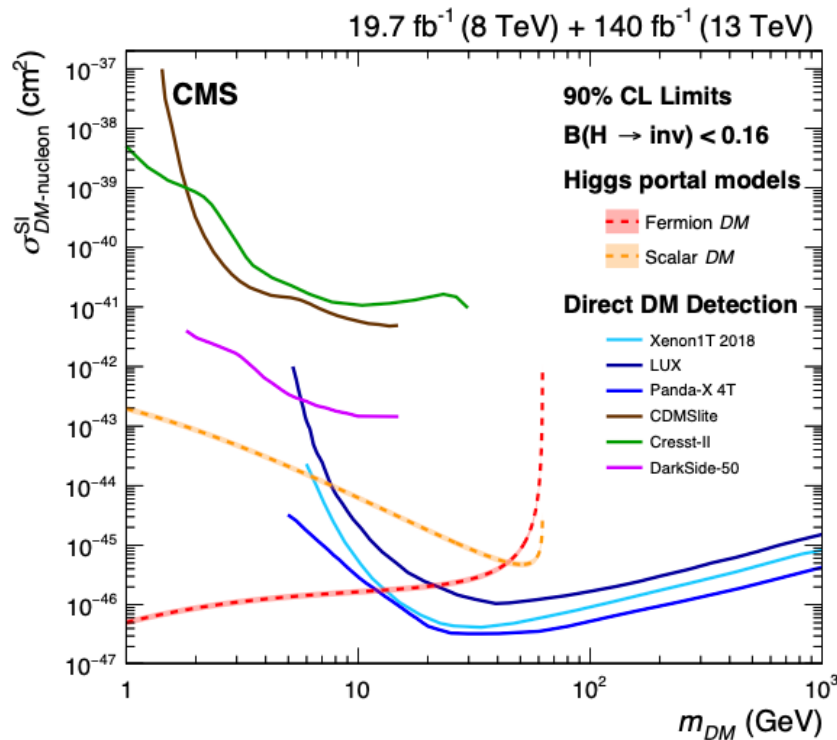

⇒ Collider results complement direct searches for low masses (<5-10GeV)

Resonant searches

Among the highest dijet mass event recorded: $m_{jj} = 8.12 \text{ TeV}$

Resonant Searches

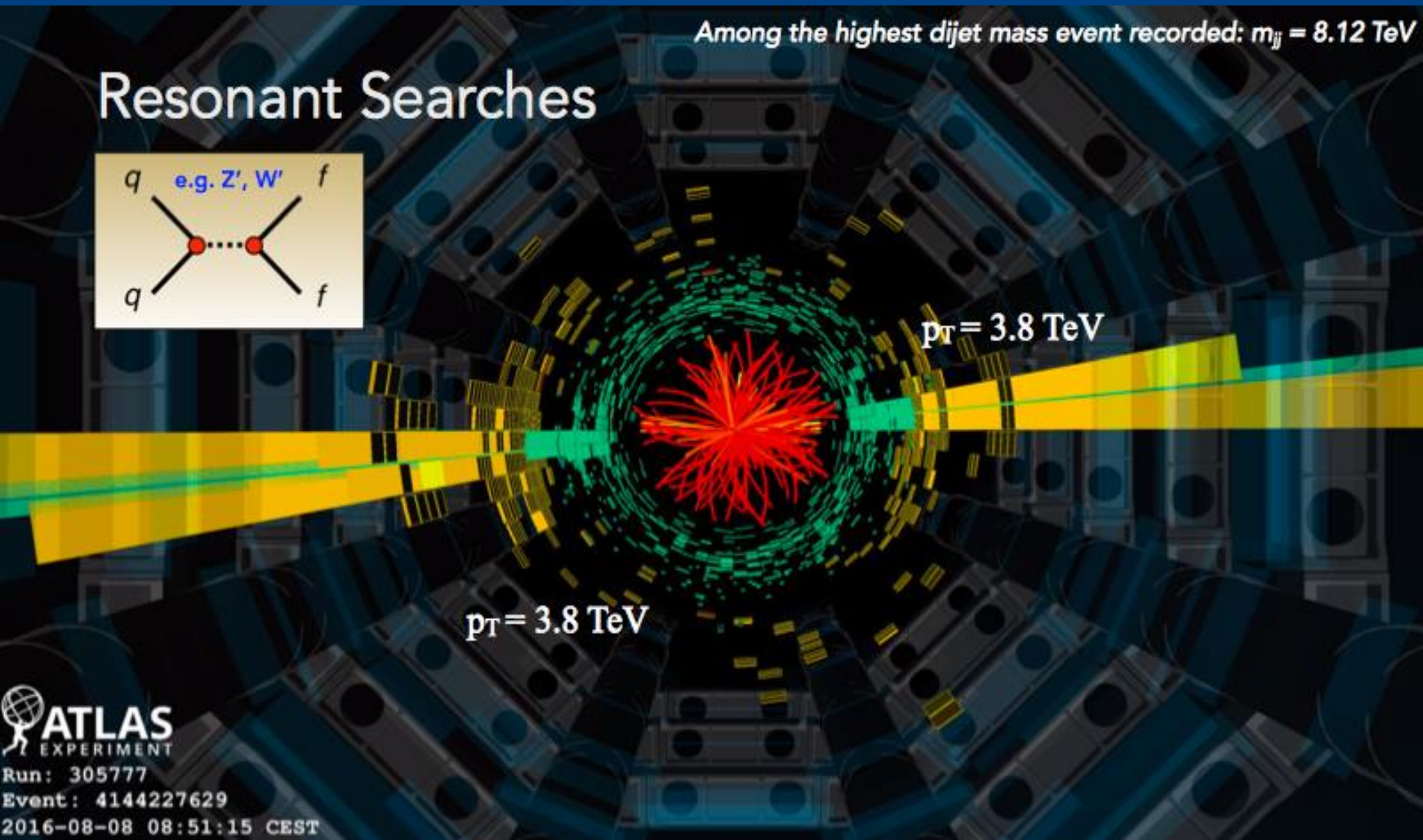
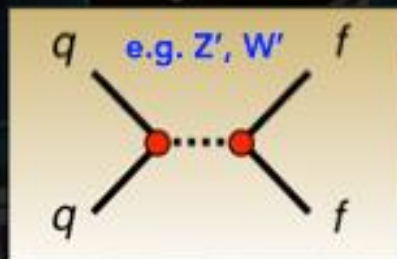

BSM models predict new resonances

- BSMs predict resonances with spin 0,1,2
- Are quarks fundamental particles?
 - Excited quarks in models of compositeness
- Randall-Sundrum (RS) models
 - Spin-2 graviton (KK-particle)
- Heavy-Vector Triplets
 - Spin-1 resonance
 - Models based on strength of vector boson interactions
- Sequential SM
 - Z' and Z with same couplings to fermions
 - Width proportional to the mass

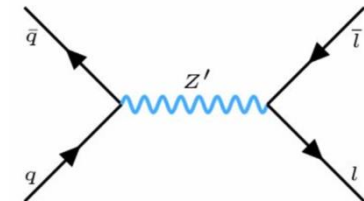
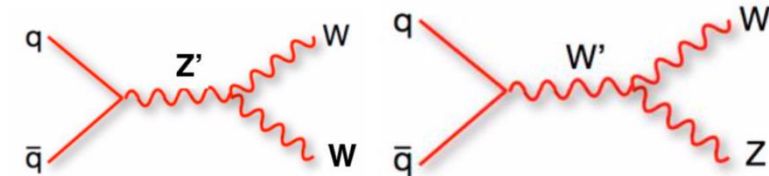
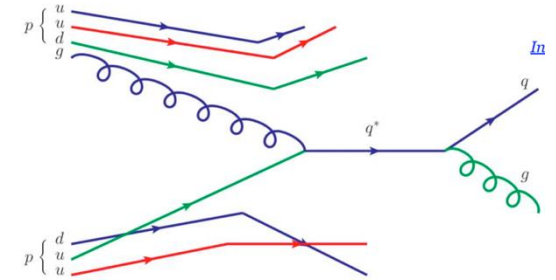

New phenomena in di-jet events

CMS-EXO-17-026, arXiv:1910.08447

- Searches up to high masses
- QCD predicts a smooth, monotonic decrease in dijet invariant mass
- Search for a localized excess
- No significant excess observed

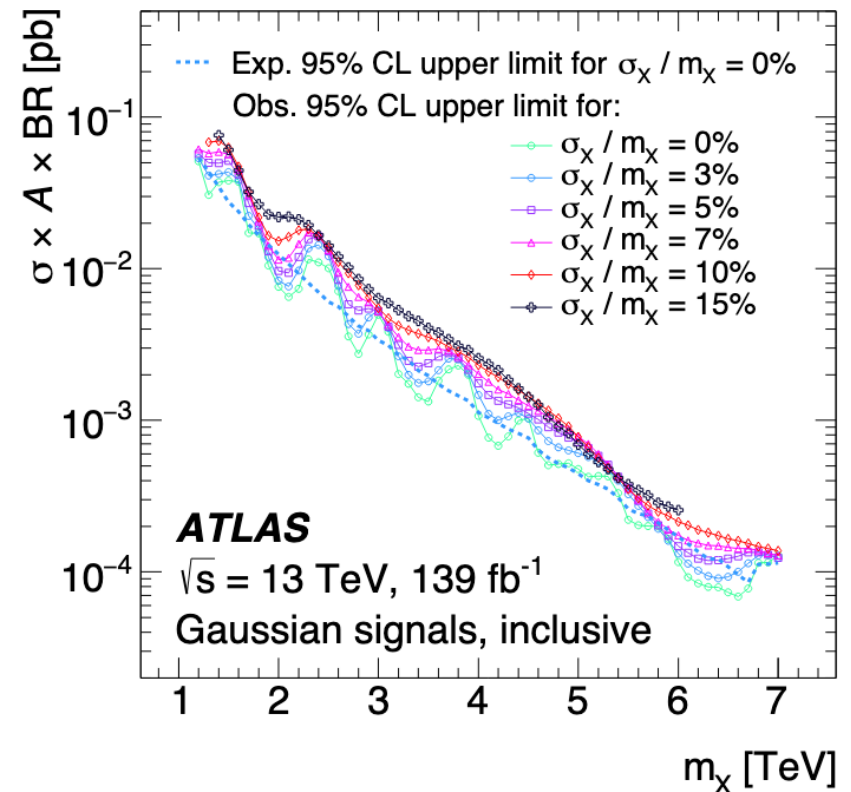
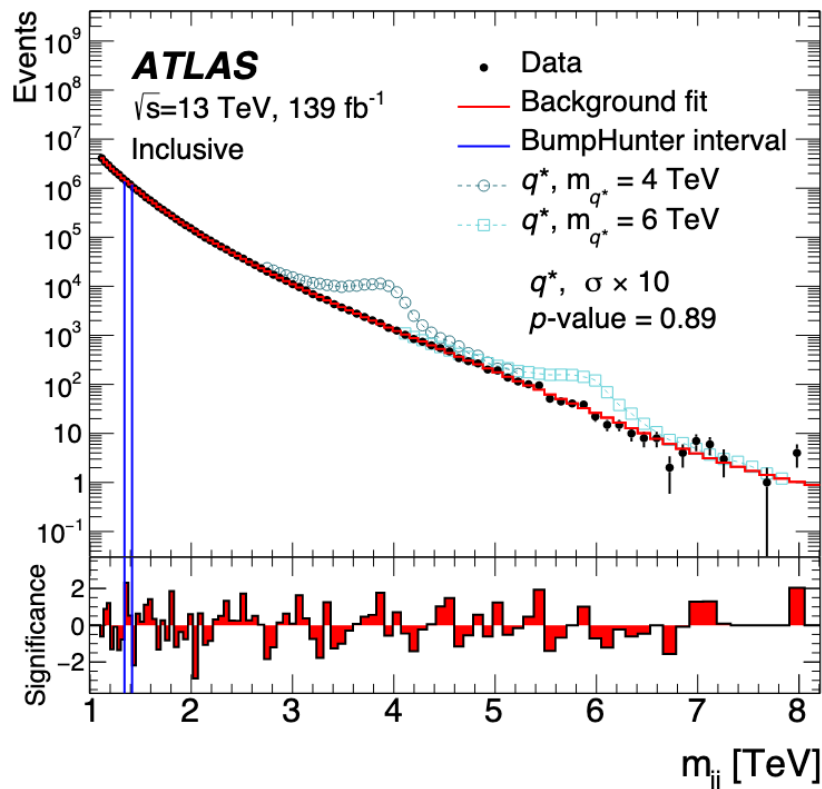

Searching for dilepton resonances

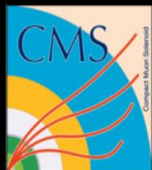

CMS Experiment at the LHC, CERN

Data recorded: 2017-Jun-27 15:39:36.789504 GMT

Run / Event / LS: 297599 / 134277310 / 86

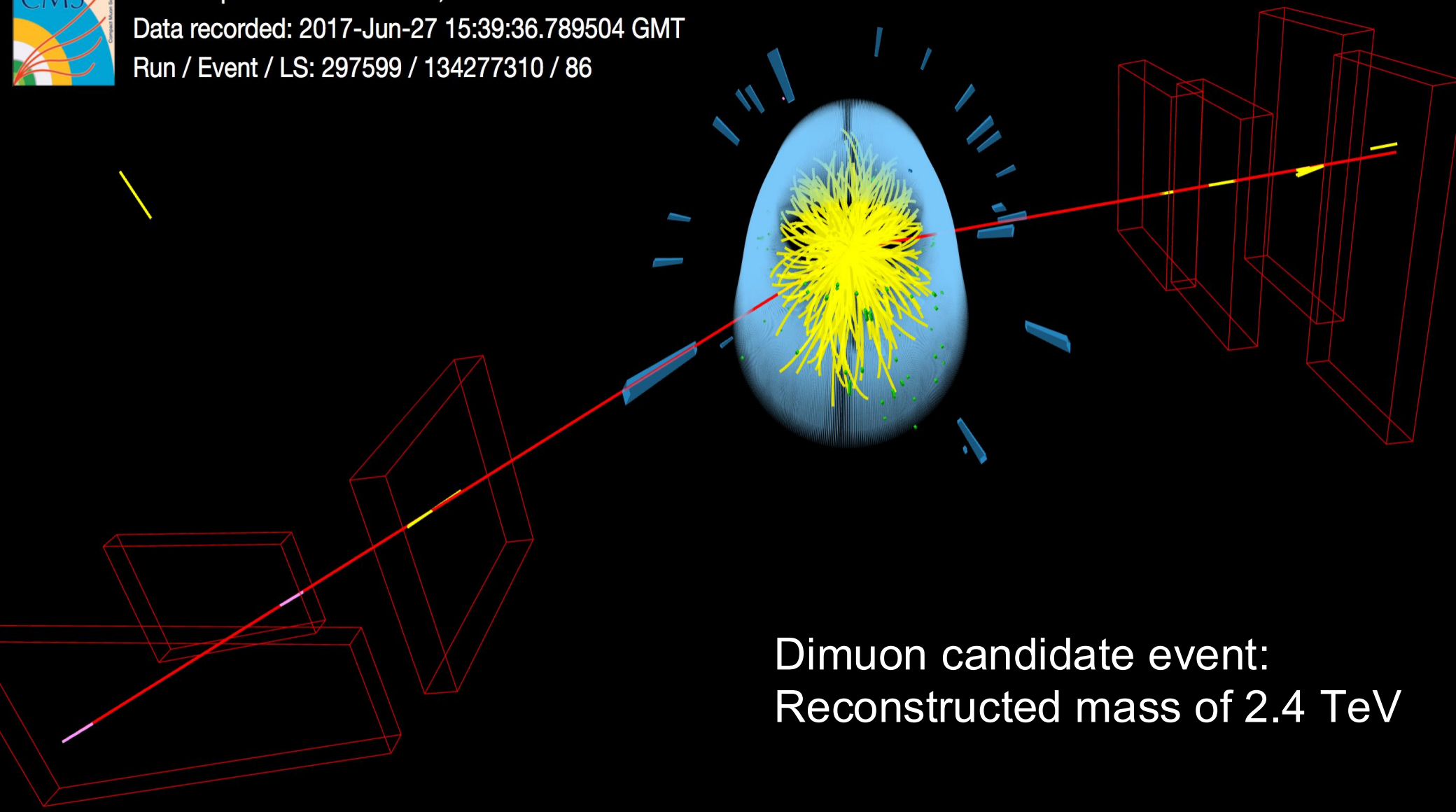

Dimuon candidate event:
Reconstructed mass of 2.4 TeV

Di-muon events

- Di-muon events: a re-discovery of the SM

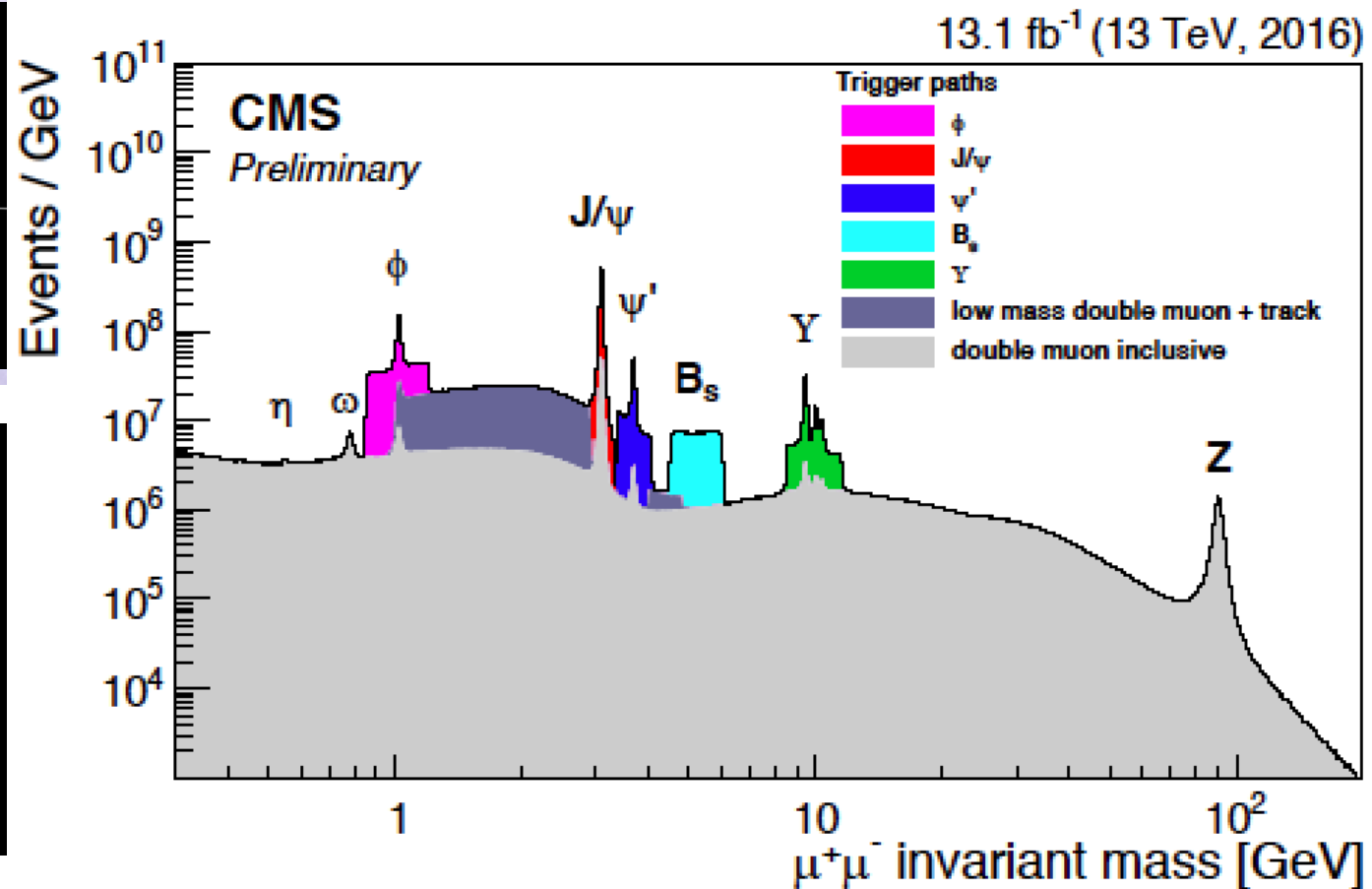
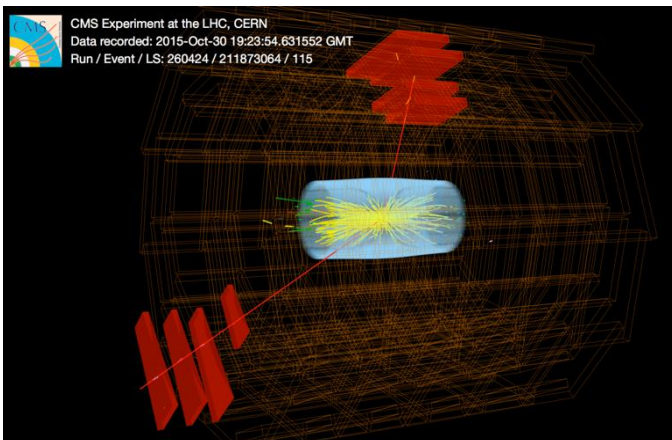
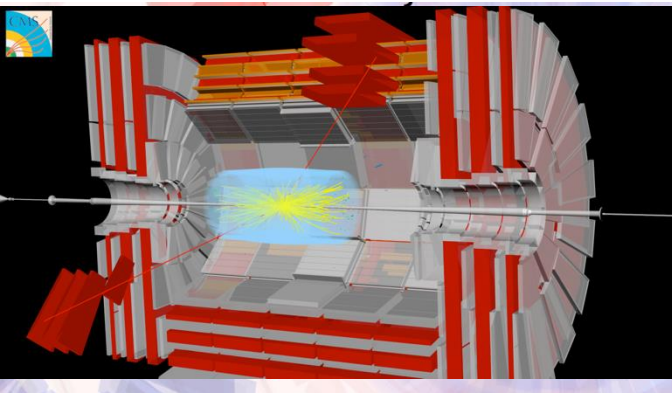

High-mass dilepton resonances

arXiv:1803.06292, arXiv:1903.06248, CMS-EXO-19-019

- Search for dilepton ($ee, \mu\mu$) resonance

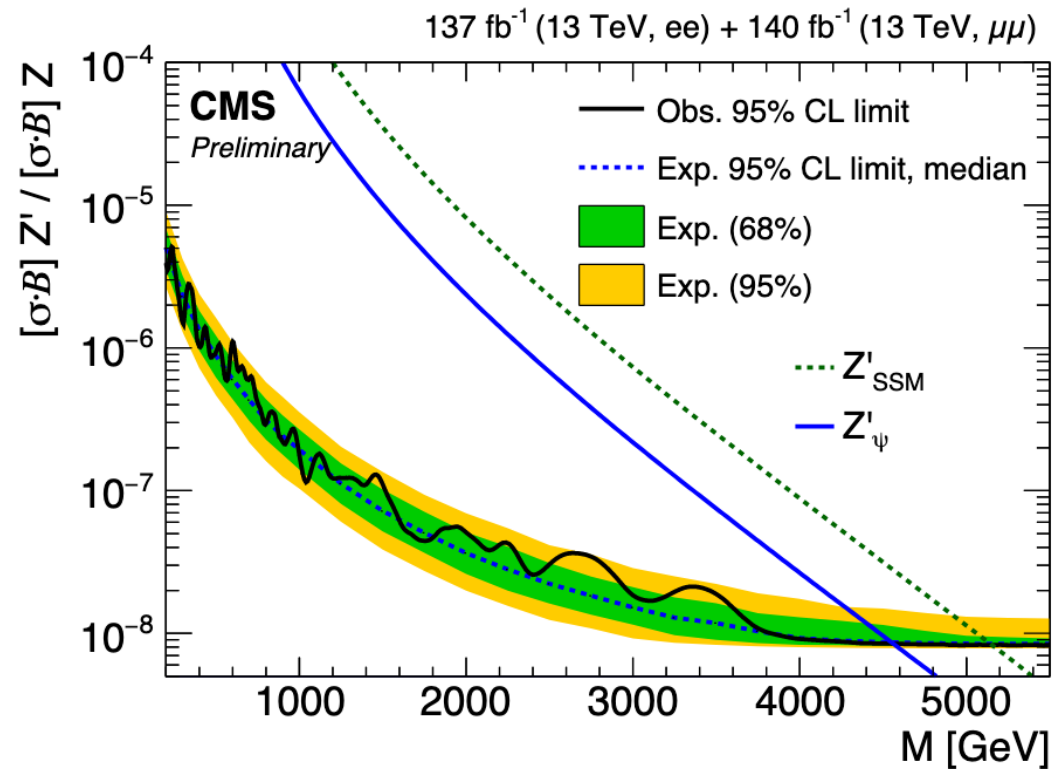
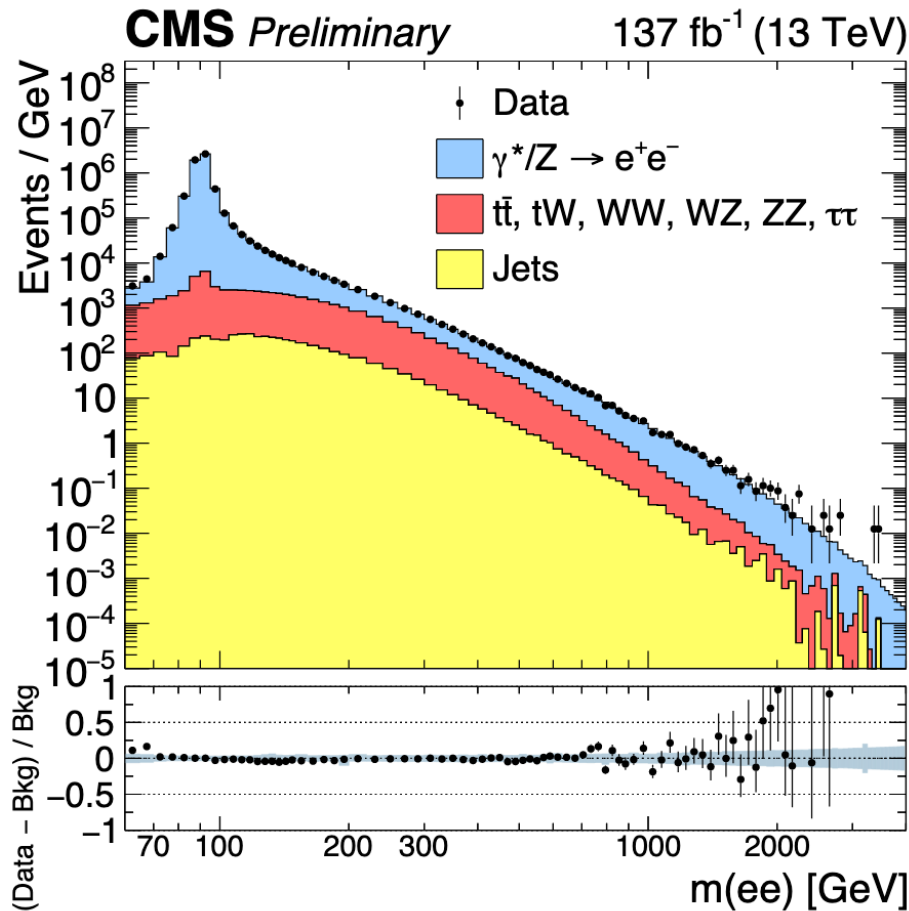

Looking forward: PPS

CERN-LHC-2014-021

- The Precision Proton Spectrometer is a joint CMS and TOTEM project that aims at measuring the surviving **scattered protons** on both sides of CMS in standard running conditions
- **Tracking** and **timing** detectors inside the beam pipe at ~210m from IP5
- Project approved in Dec. 2014 by LHCC
- Data taking started in 2016 (full scope from 2017)

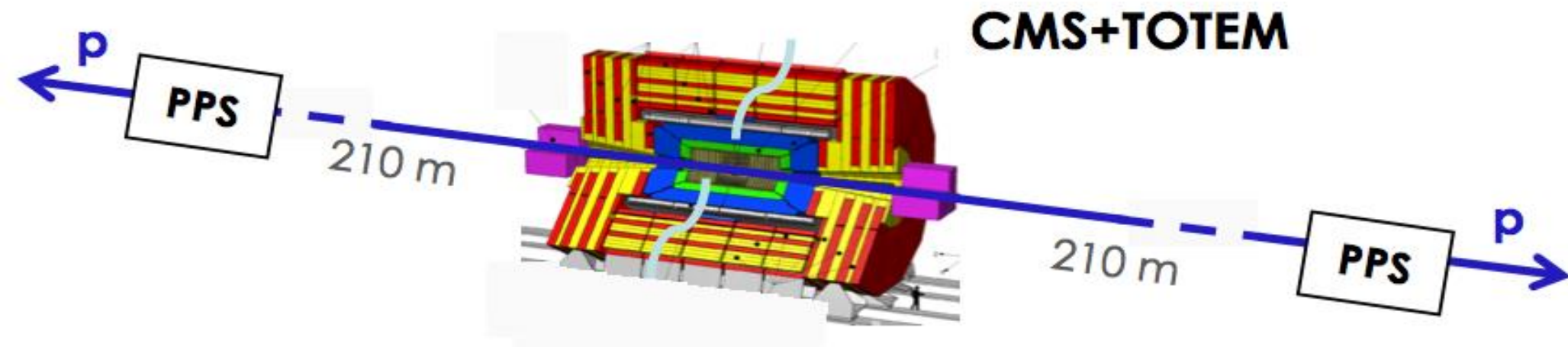
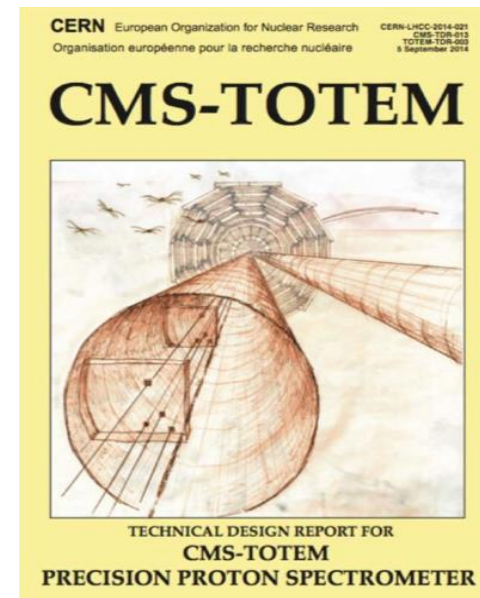

PPS physics motivations

- **Central Exclusive Production**
 - photon-photon collisions
 - gluon-gluon fusion in color singlet, $J^{PC}=0^+$
- **High- p_T system in central detector, together with very forward protons in PPS**
 - momentum balance between central system and forward protons, provides strong kinematical constraints
 - Mass of central system measured by momentum loss of the two leading protons
- **Gauge boson production by photon-photon fusion and anomalous couplings ($\gamma\gamma WW$, $\gamma\gamma ZZ$, and $\gamma\gamma\gamma\gamma$)**
- **Search for new BSM resonances**
- **Study of QCD in a new domain**

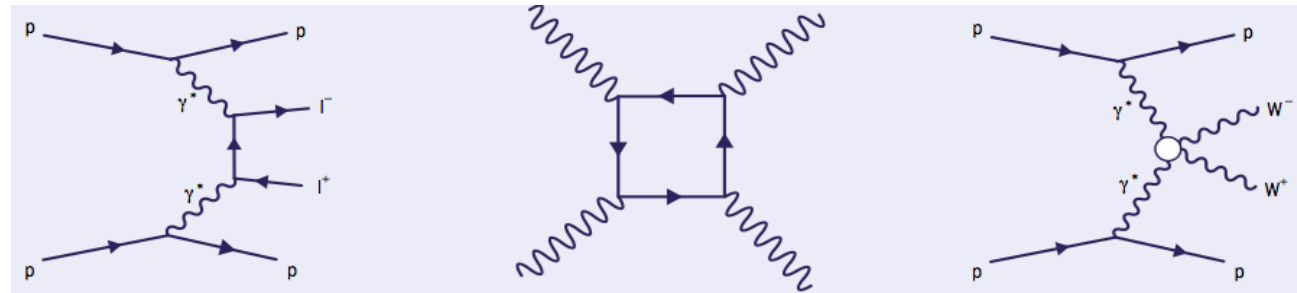

WW production

JHEP 08(2016)119

- Study of process: $pp \rightarrow pWWp$
 - Clean process: W in central detector and “nothing” else, intact protons can be detected far away from IP
 - Exclusive production of W pairs via photon exchange: QED process, cross section well known
- Backgrounds:
 - inclusive WW, $\tau\tau$, exclusive two-photon $\gamma\gamma \rightarrow ll$, etc.
- Events:
 - WW pair in central detector, leading protons in PPS
- SM observation of WW events
- Anomalous coupling study
 - AQGCs predicted in BSM theories
 - parameters: a_0^W/Λ^2 , a_c^W/Λ^2
- Deviations from SM can be large

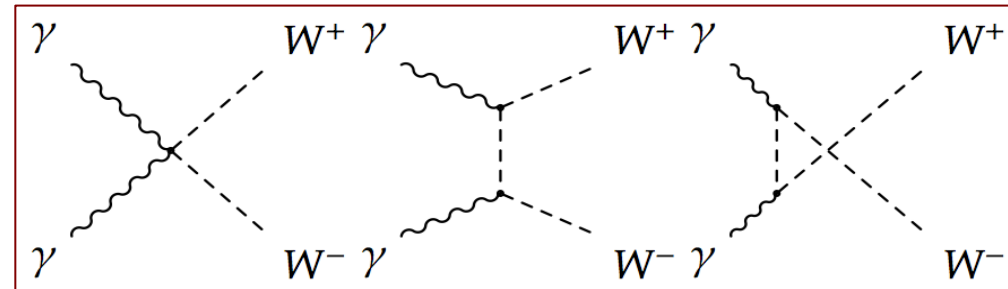
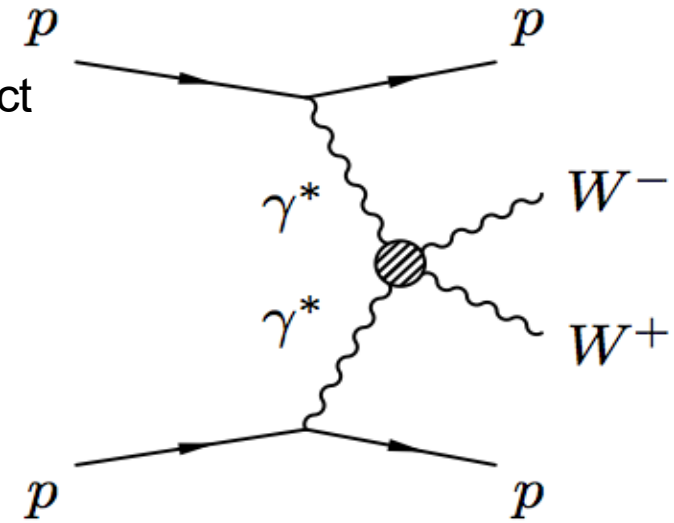

AQGC expected limits

arXiv:2211.16320

Expected limits @95%CL: $a_0^W / \Lambda^2 = 2 \times 10^{-6} (3 \times 10^{-6})$,
 $a_C^W / \Lambda^2 = 7 \times 10^{-6} (10 \times 10^{-6})$

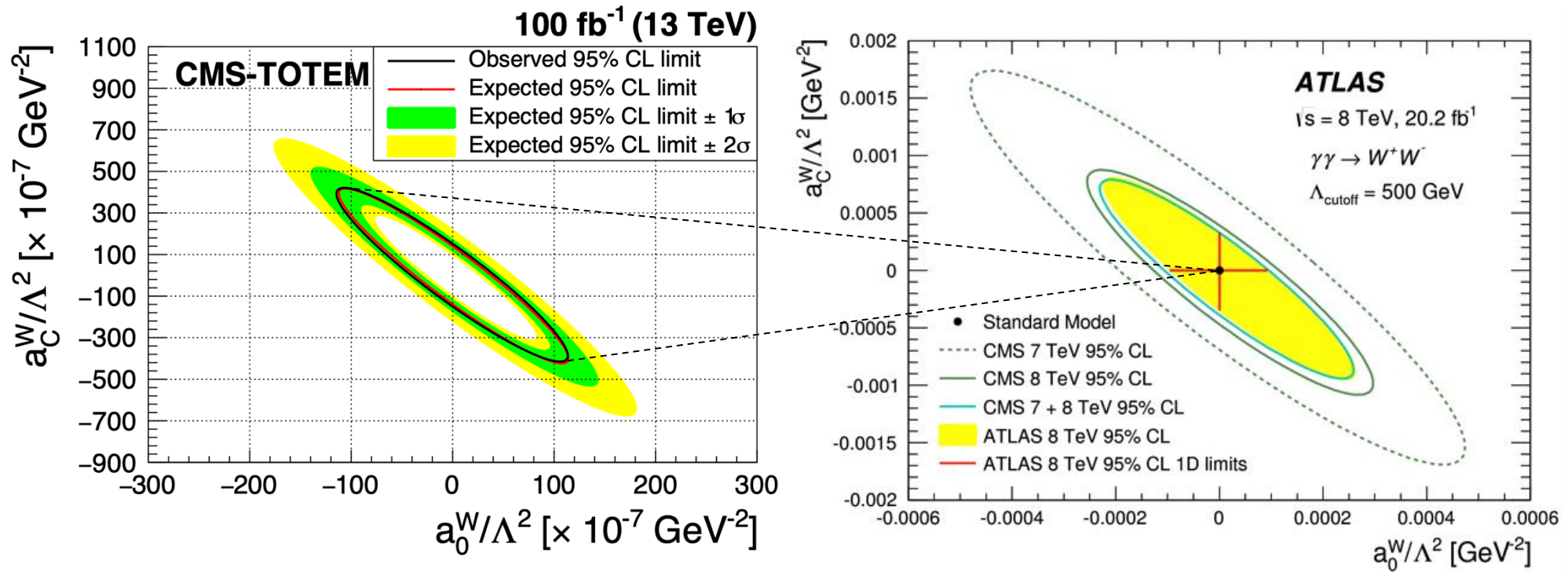

Physics with forward protons

arXiv:2210.05854, arXiv:2310.11231, arXiv:2110.05916, arXiv:2303.04596, arXiv:2211.16320

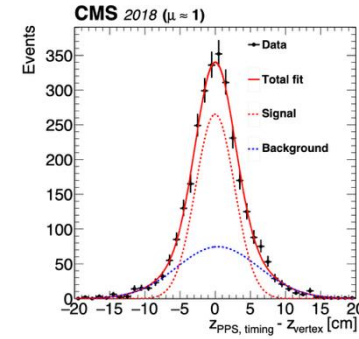
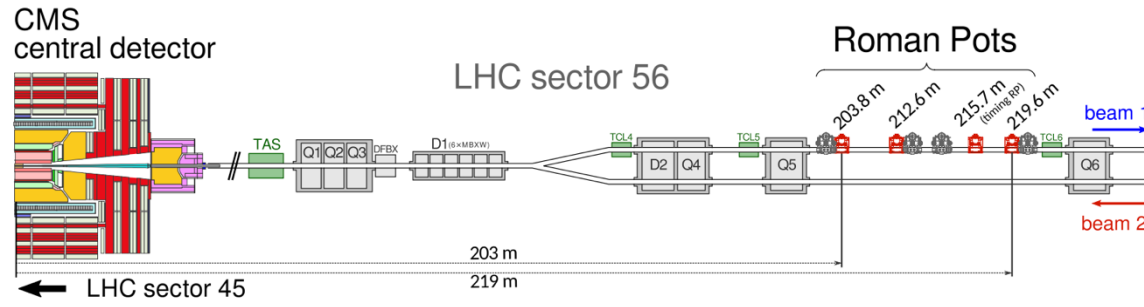

Proton reconstruction

PPS collected more than 100/fb in Run2

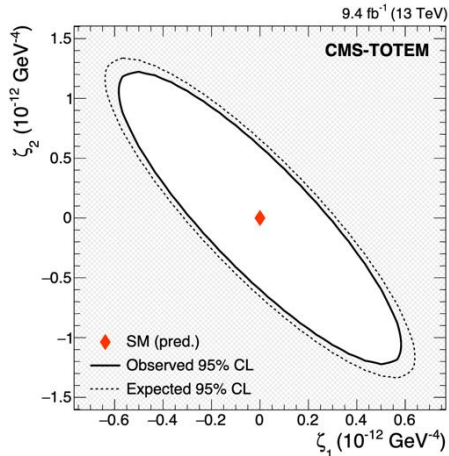

light-by-light scattering

$\gamma\gamma \rightarrow \gamma\gamma$ with forward protons, neutral quartic gauge couplings

exclusive top quark pairs

Search for $t\bar{t}$ central exclusive production in pp interactions with tagged protons

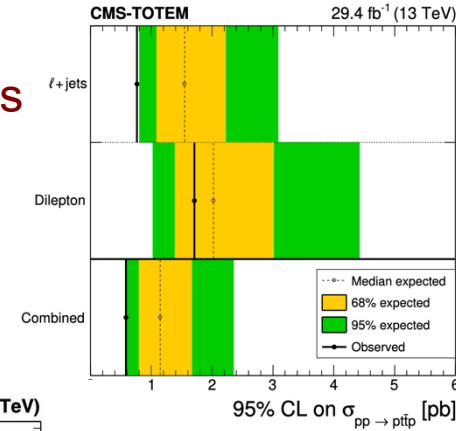

Z/γ*+X production

(2% resolution on missing mass)

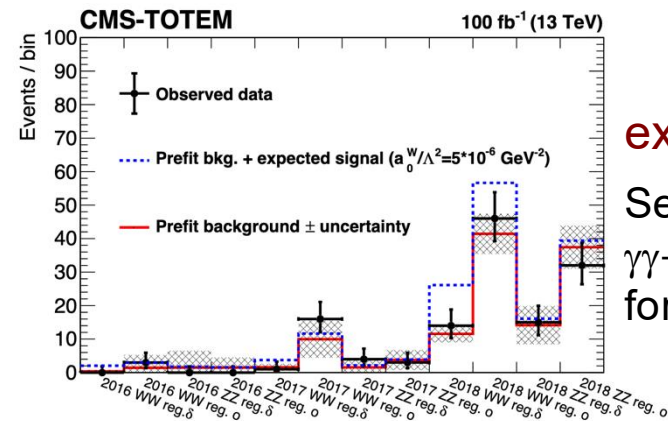
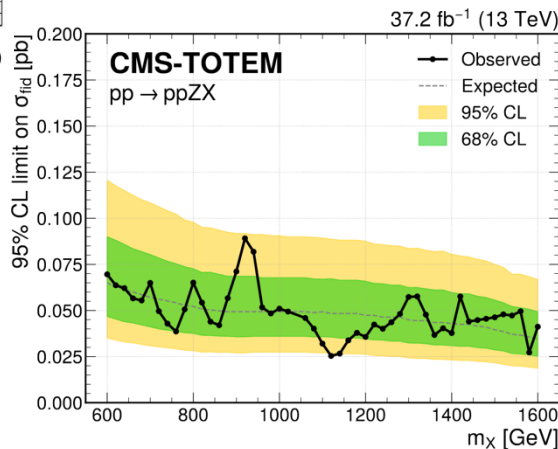

exclusive WW/ZZ

Search for $\gamma\gamma \rightarrow WW/ZZ$ with forward protons

Long-lived: Higgs decays

CMS-EXO-20-015

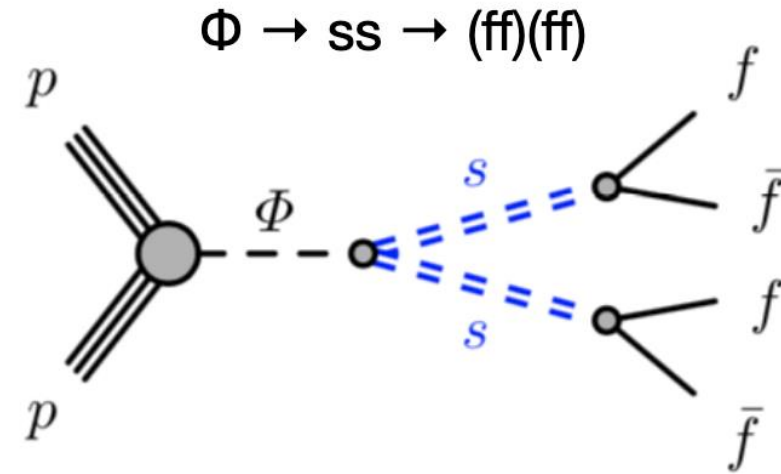
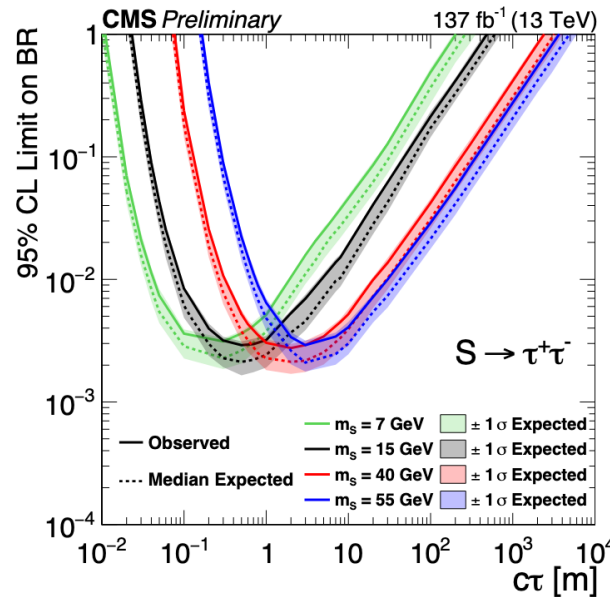
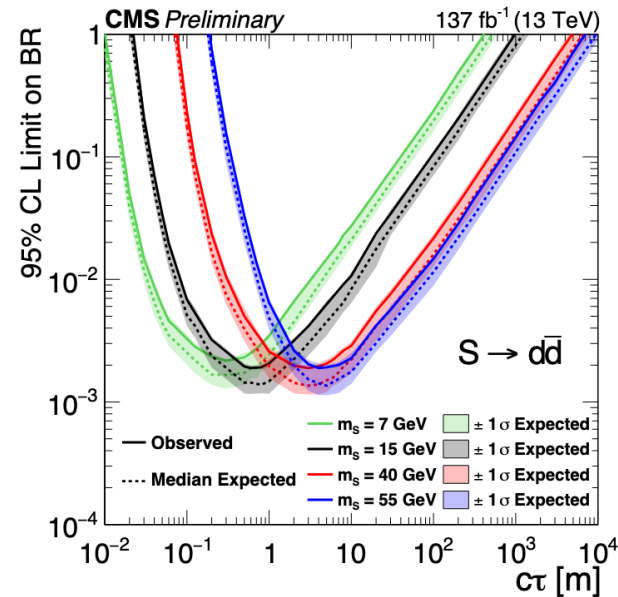

- Higgs decaying to long lived scalars
 - Scalars decay to quark final states in the muon chambers
- Resulting bounds are interpreted in context of LL decays
 - Missing energy trigger

Long-lived: Higgs portal

arXiv:2402.14491

- Production of **long-lived dark photons Z_D** via Higgs portal
- H- H_D mixing with parameter κ
- Higgs decaying to long-lived scalars
 - Scalars decay to fermion final states in the muon chambers
 - Displaced dimuon originating from secondary vertex
- Resulting bounds are interpreted in context of LL decays

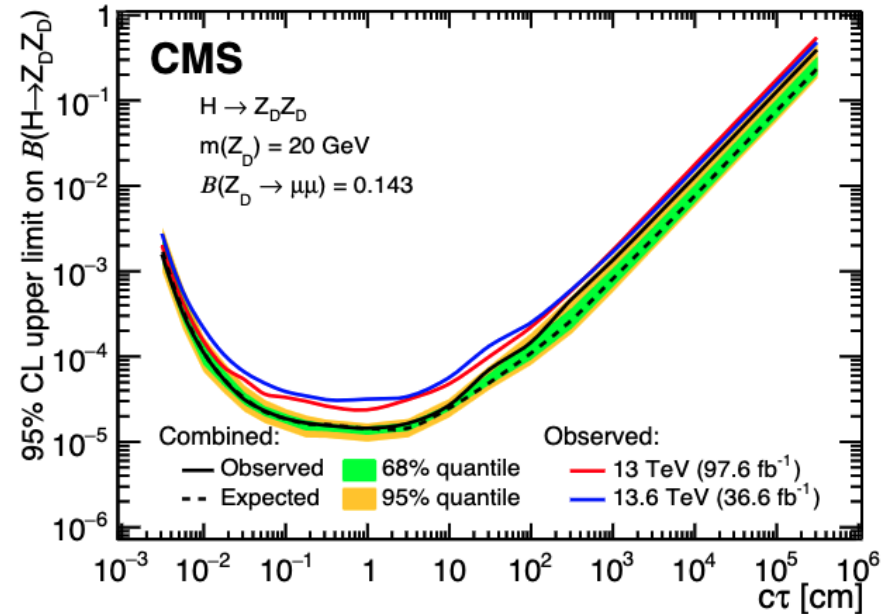
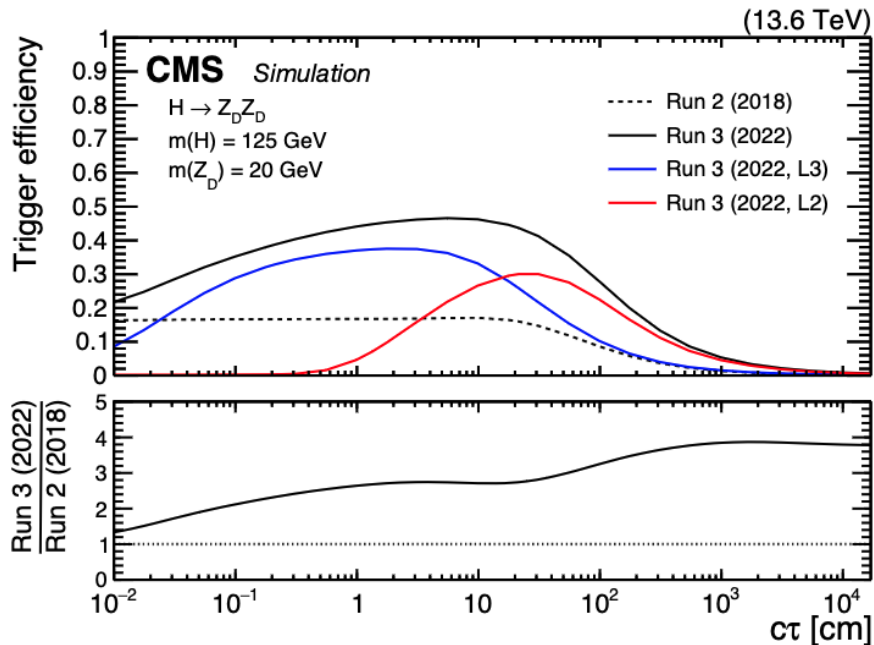
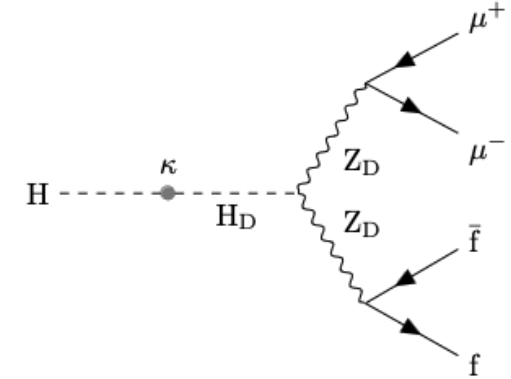

Summary

- Excellent consistency of SM but **SM is incomplete**
- Extensions foresee existence of additional bosons
- Searches for BSM bosons natural companion to precision SM Higgs boson measurements
 - Charged Higgs searches with top quark decays
 - Other BSM searches show no indication of deviations
- Searches provide **no hints for BSM yet**

